

**The Corporation of the
United Counties of Prescott and Russell**

By-law 2023-21

To regulate the use of the municipal right of way in the United Counties of Prescott and Russell.

Whereas subsection 8(1) of the *Municipal Act, 2001, S.O. 2001, c. 25*, as amended, (the “*Act*”) provides that the powers of a municipality shall be interpreted broadly so as to confer broad authority on municipalities, a) To enable them to govern their affairs as they consider appropriate; and b) to enhance their ability to respond to municipal issues;

And whereas subsection 11(3) of the *Act* provides that the Corporation of the United Counties of Prescott and Russell may pass by-laws with respect to the use of its highway and matters concerning drainage;

And whereas subsection 391(1) of the *Act* provides that without limiting sections 9, 10 and 11, those sections authorise the Corporation of the United Counties of Prescott and Russell to impose fees or charges on person, for a) Services or activities provided or done by or on behalf of it; b) Costs payable by it for services or activities provided or done by or on behalf of any other municipality or any local board; and c) The use of its property including property under its control;

And whereas section 10 of Ontario regulation 584/06 under the *Act* authorises the Corporation of the United Counties of Prescott and Russell to impose fees and charges to recover the municipality’s reasonable costs for issuing permit with respect to telecommunications, electricity and gas services and activities to place the works on a municipal highway and to cut the pavement of or otherwise dig up a municipal highway for the works;

And whereas subsection 27(1) of the *Act* authorises the Corporation of the United Counties of Prescott and Russell to pass by-laws in respect of a highway under its jurisdiction;

And whereas Council deems it expedient to regulate the construction of entrances upon any County road forming part of the County roads’ system of the Corporation of the United Counties of Prescott and Russell;

And whereas Council deems it expedient to prohibit the obstruction of drainage ditches, watercourses and other water outlets within the Corporation of the United Counties of Prescott and Russell;

And whereas Council deems it desirable that criteria should be established to govern the installation of objects in, on, within or under roads, sidewalks and road allowances under the jurisdiction of the Corporation of the United Counties of Prescott and Russell.

The Council of the Corporation of the United Counties of Prescott and Russell enacts as follows:

1. Definitions

The following definitions apply to this By-law:

“Applicant” means any person, group or corporate body who applies to the Corporation for permission to construct an entrance or a front yard ditch filling;

“Commercial Entrance” means an entrance opening onto a County Road from a property used for commercial, industrial or institutional use or a combination thereof and includes residential properties such as apartments, townhouse developments and other multiple dwelling unit developments having common parking areas;

“Corporation” or “County” or “Counties” means the Corporation of the United Counties of Prescott and Russell;

“Built-up area” means a territory contiguous to a highway, where:

- a. the posted speed limit is 60 km/h or less; and
- b. not less than 50 per cent of the frontage upon one side of the highway for a distance of not less than 200 metres is occupied by dwellings, buildings used for business purposes, schools or churches; and
- c. not less than 50 percent of the frontage upon both sides of the highway for a distance of not less than 100 metres is occupied by dwellings, buildings used for business purposes, schools or churches, or
- d. not more than 250 metres of the highway separates any territory described in clause (b) or (c) from any other territory in clause (b) or (c).

“Director” means the Director of Public Works of the Corporation of the United Counties of Prescott and Russell appointed to administer and manage the provisions of this by-law and includes his authorized subordinates and assistants.

“Engineering investigation” means exploratory excavation, and the installation and use of boreholes and monitoring wells in the road

“Entrance” means any driveway, laneway, private road, entrance or other structure or facility constructed or used as a mean of access and/or egress to and/or from a highway under the jurisdiction of the Corporation, herein defined as a County Road;

“Excavation” means breaking, digging up, tearing up, tunneling, boring, coring, attaching to, cutting into or removing of any portion of the surface or subsurface of a road, including pavement, sidewalk, curbs, ditches, gutter or the boulevard;

“Farm Entrance” means an entrance opening onto a County Road from an active farm or other agricultural use, primarily for access to barns and outbuildings;

“Field Entrance for crop harvesting” means an opening onto a County Road from a field forming part of a farm. It shall be used only for the purpose of harvesting crops, but not for access to buildings of any type and not for the passage of animals;

“Final Acceptance” means the date that the reinstated Road Cut is finally re-inspected pursuant to section 14 of this By-law.

“Front yard ditch filling” means the tiling and covering or filling in, of a County roadside ditch, in front, on the side or in the rear of the property for the purpose of improving a lawn or other frontage, sideyard or backyard;

“Hard surface” means any portion of the road including but not limited to the pavement layer(s), concrete layer(s), road base, road sub-base, gravel surface, road shoulder, shoulder rounding, sidewalks, multi-use pathway, curb and any other paved, concrete or gravel surfaces within the ROW.

“Municipal Consent” or “MC” means the written consent of the Counties, with or without conditions, to allow a public utility service to perform work within the Road right of way.

“Permit Holder” means the Person to whom a Permit is issued and includes an authorised owner, a property owner, an individual, an association, a partnership or a corporation or any other agents or contractor carrying out any works within the right-of-way.

“Preliminary Acceptance” means the date that the completed Road Cut works are initially inspect by the Counties, subject to the Final Acceptance inspection

“Public Entrance” means an entrance opening onto a County road from a public road, street or highway or other thoroughfare, maintained by a municipality or other authority;

“Public utility service” means any telecommunications, electricity and gas services company and shall include an individual, an association, a partnership or a corporation or any other agents, contractor subcontractors carrying out any works for the company.

“Residential Entrance” means an entrance opening onto a County Road from one or more residential dwelling units where there is no common parking area;

“Right-of-way” or “ROW” means a common and public highway, street, avenue, parkway, driveway, square, place, bridge, viaduct or trestle, any part of which is intended for or used by the general public for the passage of vehicles and pedestrians and includes the area between the lateral property lines thereof all of which are under the jurisdiction of the Corporation.

“Road” means a road allowance and includes all lands and structures contained within the outer limits of the allowance including grassed areas, ditches, curbs, gutters, sidewalks and other structures and includes a “Highway” as defined under the Highway Traffic Act (Ontario) which is under the jurisdiction of the Counties;

“Road Cut” means a surface or subsurface cut in any part of a Road made by any means, including any excavation, reconstruction, cutting, saw cutting, overlaying, crack sealing, breaking, boring, jacking or tunneling operations;

Security” means cash, certified cheque, letter of credit or bearer bonds approved by the Corporation of the United Counties of Prescott and Russell;

“Service Station” means a place where fuel is sold for road vehicles.

“Temporary Entrance” means an entrance that will be used for a limited period of time to permit construction or other short-term access.

“Temporary road occupation” means the temporary occupation of any portion of a road, including events in right-of-way, for the placing or operation of any machinery, vehicles, storage containers, waste bins, materials, mobile cranes, construction safety fencing, overhead construction safety fencing, temporary/mobile construction office trailers, hoists and platforms, crane booms extending from other land into the airspace over a road.

“Work” means, but is not limited to, any temporary road occupation, road cut, excavation, engineering investigation, installation, removal, construction, maintenance, repair, replacement, relocation, adjustment, breaking up, disturbance or alteration of equipment within a road.

2. Entrances and private access

2.1. Application

2.1.1. No person, group or corporate body shall undertake to construct, alter or change an entrance or the use of an entrance or shall proceed with the filling or alteration of a front yard ditch adjacent to a County Road, until he has obtained a permit issued from the Corporation and paid the prescribed fees, if any, as per the Fees and Charges By-law.

- 2.1.2. Each application for a permit shall be made on the form provided by the Director and shall be accompanied by proof of ownership of the subject property or any other requested documents satisfactory to the Director.
- 2.1.3. The installation permit shall be issued on behalf of the Corporation by the Director subject to the terms and conditions provided herein and shall be valid only upon the completion of the terms and conditions contained therein.
- 2.1.4. The cost of construction or alteration of all entrances or front yard ditch filling, including the construction of catch basins, curbs, gutters, sidewalks, islands, granular, pipes, vegetation or other necessary appurtenances shall be borne entirely by the permit holder as per the general requirement identified in Schedule D, County standards and to the satisfaction of the Director.
- 2.1.5. Every application for a permit shall be subject to a fee and security deposit, as set out in the Fees and Charges By-law. No permit shall be issued until the required security has been deposited and the fee has been paid. No fee paid for a permit shall be refunded. If the Director is satisfied that all the requirements of the permits have been met, the applicant's security deposit will be returned. In the event that a permit is not approved by the County for issuance, the security deposit is refundable. Where the Counties are aware that an application will automatically be denied and the intention of the application is to appeal the decision (e.g. following pre-consultation with the Public Works Department) the security deposit will not be required until the appeal decision is granted as per subsection 2.6 of this by-law.
- 2.1.6. Where the applicant wishes to construct an entrance and/or a front yard ditch filling, the Director shall determine the size, location and mode of construction of the culvert, bridge, pipe or other structure to be used in the construction of an entrance and/or front yard ditch filling and he shall state these requirements and any other special provisions he deems necessary on the permit issued to the applicant.
- 2.1.7. No person shall obstruct any ditch, drain, watercourse or culvert either situated on or adjacent to a County road or any ditch, drain, watercourse or culvert providing an outlet for water discharged from a County Road.
- 2.1.8. Each entrance or front yard ditch filling onto a County Road must be designed, constructed and maintained in a manner that will prevent surface water from adjoining properties being discharged via the entrance onto the travelled portion of the County Road.

2.2. Restriction regarding location of entrances

- 2.2.1. For Residential Entrance, where an alternate means of access is available, either by connection to the lower tier road system, lower traffic volume County Road, lower County Road classification, private road, fire route or a joint mutual entrance, direct access onto the County Road system, higher traffic volume County Road or higher County Road classification will be denied.
- 2.2.2. For Commercial Entrance, where an alternate means of access is available, either by connection to the lower tier road system, lower traffic volume County Road, lower County Road classification, private road, fire route or a joint mutual entrance, direct access onto the County Road system, higher traffic volume County Road or higher County Road classification will be denied unless the Director, in its sole discretion, deems a secondary Commercial Entrance appropriate for the property. In this case, the entrance shall be:
 - 2.2.2.1. Designed and constructed, to the satisfaction of the Director, to physically restrict the movements at the access point (e.g. Right in/Right with concrete centreline median) with adequate entrance spacing; or
 - 2.2.2.2. Designed and constructed, to the satisfaction of the Director, as a single lane narrow exit only (right-out) with:
 - a. proper geometric features (e.g. curbs constructed to restrict access) or physical restrictions (e.g. automatic operable gates);
 - b. adequate entrance spacing; and
 - c. which in the opinion of the Director will not be hazardous and will maintain a high level of service for through-traffic.
- 2.2.3. Each application for a permit shall be made on the form provided by the Director.
- 2.2.4. An entrance will not be permitted in a location that in the opinion of the Director would cause a traffic hazard.
- 2.2.5. A new Residential Entrance, Farm Entrance, Field Entrance or Field Entrance for crop harvesting will only be permitted if it meets all of the minimum requirements listed in Schedule B.
- 2.2.6. A new Commercial Entrance will only be permitted if it meets all of the minimum requirements listed in Schedule B.
- 2.2.7. Unless otherwise specifically indicated in this By-law, a maximum of one entrance may be approved for each existing lot. A second entrance shall not be

permitted unless it is an auxiliary Field entrance, an auxiliary Farm entrance or an auxiliary Field entrance for crop harvesting used solely for agricultural purposes or is replacing an existing entrance which is not an auxiliary field entrance and meets all of the requirements listed in Schedule B.

- 2.2.8. A maximum of two commercial entrances per lot may be approved for
- 2.2.8.1. A Service Station where it can be demonstrated that the size, shape or area of the lot is not suitable to accommodate proper vehicle manoeuvring; or
 - 2.2.8.2. Other large commercial developments which respects the entrance specifications described in this By-law where the Director, in its sole discretion, deems a secondary Commercial Entrance appropriate for the property.
- 2.2.9. A maximum of two entrances per lot may be approved where a lot is separated by a physical barrier (e.g. river, creek, stream, municipal drain).
- 2.2.10. When located within an urban residential or built-up area, a maximum of two entrances per lot may be approved to provide access for a semi-detached dwelling.
- 2.2.11. A maximum of two existing entrances per existing lot or severed lot and/or retained lot may be permitted to remain on a County Road however the Director, in its sole discretion, reserves the right to eliminate one of the two existing entrances as required in order to comply with the provisions of this By-law and the owner shall be required to apply for a permit to remove such entrance.
- 2.2.12. No new (additional) entrance permits shall be granted to existing lots which have an existing approved entrance whether shared or otherwise onto a County Road. Should an existing lot have more than one existing entrance, the Director, in its sole discretion, reserves the right to eliminate as many entrances as required in order to comply with the provisions of this By-law and the owner shall be required to apply for a permit to remove such entrance(s).
- 2.2.13. Unless for a lot severance in relation to a farm lot surplus, no new entrance for existing lot or severed and/or retained lot shall be permitted on a County Road where the average minimum spacing is less than those established in Schedule B.
- 2.2.14. Where it is not possible to meet a minimum spacing between adjacent entrances as noted in this by-law, a shared mutual entrance may be granted. A shared mutual entrance shall straddle the shared mutual property line between the two

land parcels. If a property cannot be serviced by a shared mutual entrance, approval of an entrance will be denied.

- 2.2.15. A new entrance may be permitted for an existing lot where no entrance has previously been provided, subject to the provisions of this By-Law.
- 2.2.16. A new entrance may be permitted where such a new entrance would replace an existing entrance and would establish superior entrance standards over existing conditions.
- 2.2.17. When an entrance is to be changed or altered or where the property is used for any purpose other than its original use, a permit shall be required and the installation must comply and be subject to all of the provisions set out in this by-law including but not limited to the standards established in Schedule B.

2.3. Maintenance

- 2.3.1. Property owners having access to a County Road are solely responsible for the maintenance and replacement of the access including but not limited to the removal of snow and ice, shoulder gravel and winter sand, keeping the portion of the access within the right-of-way in a safe condition for vehicular traffic. Such property owner shall ensure the replacement of all portions of the access as and when necessary. A culvert pipe or any other structure installed under the terms of this by-law shall be the property of the property owner and all subsequent maintenance, repairs, alterations, replacements, etc., shall be the responsibility of the property owner.
- 2.3.2. Any existing entrance or any entrance installed under the terms of this by-law shall be the property of the property owner upon acceptance of the work and all subsequent maintenance, repairs, alterations, replacements, surface repairs etc., shall be the responsibility of the property owner. The applicant or his successor shall maintain and replace from time to time, as required, any works installed under the provisions of this By-Law and installed prior to the passing of this By-Law.
- 2.3.3. Any existing front yard ditch filling or any front yard ditch filling installed under the terms of this by-law shall be the property of the property owner upon acceptance of the work and all subsequent maintenance, repairs, alterations, surface repairs etc., shall be the responsibility of the property owner. The property owner shall maintain and replace from time to time, as required, any works installed under the provisions of this By-Law and works installed prior to the passing of this By-Law.
- 2.3.4. Head walls, retaining walls or structures (ie pillars, timber/railway tie/ block/ stone/ brick walls or any other type of material) at culverts shall not be permitted

within the County road allowance. These shall be removed by the applicant upon written direction issued by the Director. The Public Works Department shall not be responsible for replacing any structures connected with any entrance while doing any maintenance work within the road allowance.

- 2.3.5. Curbing shall be permitted for commercial and/or urban entrances provided it conforms to the Ontario Provincial Standard Drawings, Specifications and/or the County Standards and to the satisfaction of the County.
- 2.3.6. Where an existing entrance is affected solely by the reconstruction of a County Road or the reconstruction or cleaning of a ditch, the County shall reinstate, at the County's cost, the affected entrance only when the reconstruction of the entrance or the cleaning or reconstruction of the ditch is required by the County or for the Counties purposes. County shall reinstate the surface with asphalt or gravel. The property owner shall be responsible for the reinstatement of any other type of material on the surface. Any original materials of construction salvaged, shall remain the property of the County.
- 2.3.7. The County shall maintain the authority to relocate/close any entrance that does not comply with any section of the by-law.
- 2.3.8. Where an existing entrance is affected by a road construction, modification or improvement project, the County shall maintain the authority to relocate any entrance, at the County's costs, where it is cost effective for the County and/or for safety reasons.
- 2.3.9. Where a property is affected by a road construction, modification or improvement project and where there is more than one entrance for the lot being affected, the County shall maintain the authority to close any entrance with the exception of one entrance, at the County's costs.

2.4. Temporary Entrance

- 2.4.1. Notwithstanding the provisions of this by-law, Temporary Entrances may be permitted by the Director. The Director shall specify the mode of construction, establish the standards and specifications of construction and establish the time period the Temporary Entrance shall be permitted to exist.
- 2.4.2. If at the end of the specified time period for which a Temporary Entrance installation permit was issued, the said permit is not renewed by the Director, or the structure of the entrance removed, the applicant to which the permit was issued shall be deemed to be causing an obstruction and the provisions of this by-law shall be applied.

2.5. Time Limit

- 2.5.1. The construction of an entrance or a front yard ditch filling, in accordance with the specifications established in this By-Law, shall be completed within six (6) months from the date of issuance of the installation permit. The Director may, upon application, renew or extend any permit issued under this By-Law, at no charge to the applicant, if it is deemed appropriate by the Director, in his sole discretion.
- 2.5.2. The County reserves the right to refuse approval of any application or remove an existing entrance should it be determined that any one of the objectives or requirements of the By-Law is or will be compromised as determined at the sole discretion of the Director.

2.6. Appeal of refusal of entrance

- 2.6.1. Entrance applications that do not conform to this by-law shall be denied and the applicant shall be so informed in writing within five days of the Director's decision. The applicant's security deposit, if received by the Counties at the time of the application as per the Fees and Charges By-law, will be retained by the Counties for a period of sixty (60) calendar days following the application refusal, unless the applicant confirms by writing that he will not be proceeding with an appeal to a decision. If no application for an appeal is made to the Director after sixty (60) calendar days, the Counties will release the deposit. A person who wishes to appeal a decision of the Director made pursuant to this by-law may appeal the Director's decision in accordance with the following:
 - 2.6.1.1. An application for an appeal shall be made to the Director within sixty (60) calendar days of the date of the denied application letter and shall be accompanied by a non-refundable administrative fee as specified in the Fees and Charges By-law for each denied application under the provisions of this by-law;
 - 2.6.1.2. County Council (or a Committee to whom this function has been delegated) shall, within a reasonable time after receiving an application for an appeal, hold a hearing at a place and time determined by County Council (or the applicable committee) in order to allow the applicant an opportunity to make representations. A written summary of the applicant's presentation to the Committee or Council must be submitted to the Director no less than ten business days before the date of the hearing. The applicant's summary shall be distributed to County Council (or the applicable committee). The applicant's verbal presentation to County Council (or the applicable committee) shall be no longer than ten minutes.

- 2.6.1.3. Should the applicant's appeal be granted, the applicant security deposit will be retained and the permit fee as per the Fees and Charges By-law shall not apply if already paid in the original application. If no security deposit was deposited with the application, the applicant must provide the security deposit as specified in the Fees and Charges By-law in order to receive the permit.
- 2.6.1.4. Should the applicant's appeal be denied, the permit fee as per the Fees and Charges By-law will not be refunded to the applicant. The security deposit will be returned if it was received by the Counties at the time of the application.

3. Work in right of way

3.1. Application

- 3.1.1. No person, group, municipality, public utility service or corporate body shall undertake any work within the County Road right-of-way without first obtaining a permit issued from the Corporation.
- 3.1.2. Every application for a work in right-of-way permit shall be made to the Director on the prescribed form and no permit shall be issued until the required permit fees and security deposit, as prescribed in the Fees and Charges By-law, has been paid and deposited to the Corporation.
- 3.1.3. This By-law shall not apply so as to require a security deposit from a public utility service or a subcontractor acting on behalf of the public utility service in the Counties unless stated otherwise in the executed Municipal Access Agreement between the Corporation and the public utility service.
- 3.1.4. If a public utility service has obtained a Municipal Consent and paid the prescribed permit fees, the public utility service or its subcontractor executing the work will be required to obtain a work in right of way permit however will be relieved from the permit fees as set out in the Fees and Charges By-law.
- 3.1.5. If a public utility service or a permit holder has obtained a municipal consent or a permit and has not commenced construction of the approved work associated with a particular MC or permit within one (1) year of the date of issuance of the MC or permit and has not sought and received an extension to the MC or the permit from the Counties, which extension shall not be unreasonably withheld, the MC or permit shall be null and void. Furthermore, if onsite work has not commenced within ninety (90) days of issuance of the work in right-of-way permit in relation to a particular MC or permit, the public utility service or permit holder must notify the Counties two (2) weeks prior to starting the work. The Director may, upon application, renew or extend any permit issued under this By-Law, at no charge to the applicant, if he deems it expedient.

3.2. Reinstatement

- 3.2.1. Every work in right of way shall be reinstated as per the County standards and to the satisfaction of the County.
- 3.2.2. The permit holder shall remain responsible for satisfactory performance of the reinstatement of the work in right of way for a period of two (2) calendar year following the date of the Preliminary Acceptance.
- 3.2.3. After the expiration of two (2) calendar years from the date of the Preliminary Acceptance, the reinstated work in right-of-way shall be re-inspected and, if not approved for Final Acceptance, the permit holder shall repair the deficiencies as stated by the Director, to the satisfaction of the Counties.

4. Event in right-of-way

- 4.1.1. No person, group, municipality or corporate body shall undertake any event which requires the occupation and disruption of traffic within the right-of-way without first obtaining a permit issued from the Corporation and paid the prescribed fees, if any, as per the Fees and Charges By-law.
- 4.1.2. Each application for an event permit shall be made on the form provided by the Director and shall be accompanied by a letter of support or resolution from the local municipality supporting the event and/or any other requested documents satisfactory to the Director.

5. General

5.1. Application

- 5.1.1. Section 5 of this by-law applies to all work prescribed in this by-law.
- 5.1.2. All works described in this by-law shall conform and be completed as per the County standards and to the satisfaction of the County.

5.2. Remedial Action

- 5.2.1. Every person who fails to comply with the requirements set out in this By-law, shall by the date specified within any notice by the County, take all necessary steps to comply. The notice shall contain:
 - 5.2.1.1. The municipal address and/or the legal description of the property on which the person fails to comply with the requirements set out in this By-law;
 - 5.2.1.2. A description of the By-law and/or the permit provisions that have not been complied with;

- 5.2.1.3. A statement that the works, entrance and/or front yard ditch filling must be brought into compliance with the provisions of this By-law and/or the conditions of the permit issued, if any, for the works, entrance and/or front yard ditch filling or to remove the works, entrance and/or front yard ditch filling within the time specified; and
- 5.2.1.4. A statement that if the notice is not complied with, the County may do the work at the expense of the applicant, permit holder or person failing to comply.
- 5.2.2. A notice issued under this by-law shall be served personally to the applicant, permit holder or the person failing to comply or by prepaid registered mail to the last known address of the applicant, permit holder or the person failing to comply.
- 5.2.3. In the event that an entrance or front yard ditch filling has not been constructed or installed in accordance with the Permit, it shall be reinstated or removed by the applicant, permit holder or the person failing to comply upon written notice issued by the County. Failure to do so will result in the reinstatement or removal by the County at the expense of the applicant, permit holder or person failing to comply and the cost thereof shall be deducted from the security deposit held by the Counties, if any, and the applicant, permit holder or person failing to comply shall be liable to the Counties for any shortfall.
- 5.2.4. Any person found to be obstructing a drain, ditch, watercourse or culvert, shall, when requested, verbally or by written notice, by the Director to do so, remove the obstruction within such time as is reasonable having regards to all circumstances but, in any event, if for an emergency, within twenty-four (24) hours. Failure to do so will result in the removal of the obstruction by the County at the expense of the permit holder or the person failing to comply.
- 5.2.5. In the event that a person fails to comply with the notice provided by the County, the County may do the work at the expense of the applicant, permit holder or the person failing to comply.
- 5.2.6. In the event of unsatisfactory performance by the reinstated work in right-of- way during the two (2) year period following Preliminary Acceptance or of unsatisfactory condition on final inspection, the permit holder shall be notified of remedial works required and if such required work has not been satisfactorily completed within five (5) working days from notification, the Director shall have the required work completed at the applicant, permit holder's or person failing to comply sole expense, and the cost thereof shall be deducted from the security deposit held by the Counties, if any, and the applicant, permit holder or person failing to comply shall be liable to the Counties for any shortfall.

5.2.7. Any costs incurred by the County pursuant to Section 5 of this by-law which are in excess of the amount deposited at the time of the permit, if any, shall be paid by the applicant, permit holder or the person failing to comply to the County within thirty (30) days of the mailing of an invoice by the County addressed to the applicant, permit holder or the person failing to comply at its last known address for such amount in excess. Pursuant to Section 446(3) of the *Municipal Act, 2001*, S.O. 2001, c.25, any costs incurred by the County under this clause may be recovered in like manner and with the same priority as municipal taxes, through a request by the County to the applicable local municipality.

5.3. Exception

5.3.1. This By-Law shall not apply so as to require a permit fee and a security deposit from any local municipality, in the Counties nor to any railway incorporated under the laws of Canada.

5.4. Notice for temporary closing of a highway

5.4.1. Prior to any work in the right of way which will result in the complete closing of the Road to traffic during any part of a day, the applicant or the permit holder shall comply and respect the Temporary closing of a highway Section pursuant to the Corporation's By-law that temporarily authorize lower rate of speeds, construction zones, stop signs and road closure and to temporarily prohibit heavy trucks on County roads, as amended.

5.5. Traffic Control Plan

5.5.1. Prior to any work in the right-of-way the applicant or permit holder shall hire a "competent person" as defined under the Occupational Health and Safety Act and shall submit a Traffic Control Plan as per the Ontario Traffic Manual Book 7, as amended, to the Director, which Traffic Control Plan must be approved in writing prior to proceeding with any work.

5.6. Insurance

5.6.1. If the Corporation has deemed the work carried out to be non-specialized and approved the undertaking party and permit holder to be the landowner(s) they shall provide and maintain for the duration of the project a Habitational Insurance policy specified in Section 1 of Schedule A of this by-law.

If the Corporation has deemed the work carried out to be non-specialized and identified an exposure to third parties yet conditionally approved the undertaking party and permit holder to be the landowner(s) they shall provide and maintain for the duration of the project a Commercial General Liability Insurance policy specified in Section 2 of Schedule A of this by-law.

If the Corporation has deemed or been advised that the work carried out to be by a "competent person" as defined under the Occupational Health and Safety Act

the “competent person” shall provide and maintain for the duration of the project applicable insurance policies as set out in Section C of Schedule A of this by-law.

- 5.6.2. For work in right-of-way permit, the insurance coverage referred to above shall be maintained for three (3) years following the date of Preliminary Acceptance.

5.7. Indemnification

- 5.7.1. The permit holder shall defend, indemnify and save harmless the Corporation, their elected officials, officers, and employees from and against any and all claims, actions, losses, expenses, fines, costs (including legal costs), interest or damages of every nature and kind whatsoever, including but not limited to bodily injury or to damage or destruction of tangible property including loss of revenue arising out of or allegedly attributable to the negligence, acts, errors, omissions, execution, failure to execute, improper workmanship from any and all work authorized by this by-law, whether willful or otherwise, on the part of the permit holder, their officers, agents, employees, volunteers, guests, invitees, contractors, subcontractors or others who the applicant is legally responsible. This indemnity shall be in addition to and not in lieu of any insurance to be provided by the permit holder in accordance with this by-law.

5.8. Responsibility for claims

- 5.8.1. A permit holder shall be responsible for all loss or damages arising directly or indirectly from the work done by or for the permit holder.
- 5.8.2. Where a road or public utility within the right-of-way has been damaged by a permit holder, the reinstatement of such damaged infrastructure shall be completed in conformance to the Corporation or subject public utility standards.

5.9. Offence and Penalty Provisions

- 5.9.1. Any person who contravenes the provisions of this by-law may be guilty of an offence and, is subject to a fine under the applicable legislation.

5.10. Repeal

- 5.10.1. By-law Numbers 2013-26, 2021-19 and 2021-42 are hereby repealed.

By-law read a first, second, and third time, and passed on May 24, 2023.

Normand Riopel, Warden

Mélissa Cadieux, Clerk

Schedule A to By-law 2023-21

Section 1 - Minimum insurance requirements for entrance and front yard ditch filling for landowner(s)

The landowner(s), at the application process and prior to the commencement of work, shall provide and maintain for the duration of the project, a Habitational Insurance policy with a liability limit of not less than \$2,000,000 per occurrence.

Prior to commencement of work, the landowner shall provide to the Counties with a copy of their policy or confirmation by way of a certificate of insurance confirming the aforementioned insurance. The insurance policy will be in a form and with a company which are, in all respects, acceptable to the Counties.

Section 2 - Minimum insurance requirements for entrance and front yard ditch filling for landowner(s) if County identified an exposure

Commercial General Liability Insurance

Commercial General Liability Insurance issued on an occurrence basis for an amount of not less than \$2,000,000. per occurrence / \$2,000,000. annual aggregate for any negligent acts or omissions by the landowner(s) relating to their obligations under this provision. Such insurance shall include, but is not limited to bodily injury and property damage including loss of use; personal injury; contractual liability; premises, property & operations; non-owned automobile; broad form property damage; broad form completed operations; owners & contractors protective; occurrence property damage; products; volunteers as Additional Insured(s); contingent employers liability; tenants legal liability; cross liability and severability of interest clause

This insurance shall be non-contributing with and apply as primary and not as excess of any insurance available to the Counties.

Automobile Liability Insurance

Automobile liability insurance with respect to owned or leased vehicles used directly or indirectly in the performance of the services covering liability for bodily injury, death and damage to property with a limit of not less than \$1,000,000. inclusive for each and every loss.

Environmental Impairment Liability (if applicable)

The landowner shall effect and maintain Environmental Impairment Liability with a limit of not less than \$1,000,000. Per Incident /Annual Aggregate. Coverage shall include Third Party Bodily Injury and Property Damage including on-site and off-site clean-up. If such insurance is issued on a claims made basis, such insurance shall be maintained for a period of two years subsequent to conclusion of services provided under this Agreement.

Prior to commencement of work, the landowner and / or permit holder shall provide to the Counties with a certificate of insurance or copies of the policies confirming the aforementioned insurance. The insurance policy will be in a form and with a company which are, in all respects, acceptable to the Counties.

Section 3 - Minimum insurance requirements for any work in right-of-way when performed by a contractor

Commercial General Liability Insurance

Commercial General Liability Insurance issued on an occurrence basis for an amount of not less than \$5,000,000. per occurrence / \$5,000,000. annual aggregate for any negligent acts or omissions by the contractor while carrying out the work associated with the road permit. Such insurance shall include, but is not limited to bodily injury and property damage including loss of use; personal injury; contractual liability; premises, property & operations; non-owned automobile; broad form property damage; broad form completed operations; owners & contractors protective; occurrence property damage; products; employees as Additional Insured(s); contingent employers liability; tenants legal liability; cross liability and severability of interest clause.

Such insurance shall add the United Counties of Prescott Russell and the landowner and permit holder as Additional Insured with respect to the operations of the contractor. This insurance shall be non-contributing with and apply as primary and not as excess of any insurance available to the Counties and/or landowner. The contractor shall indemnify and hold United Counties of Prescott Russell and the landowner harmless from and against any liability, loss, claims, demands, costs and expenses, including reasonable legal fees, occasioned wholly or in part by any negligence or acts or omissions whether willful or otherwise by the contractor, their officers, employees or other persons for whom they are legally responsible.

Automobile Liability Insurance

Automobile liability insurance with respect to owned or leased vehicles used directly or indirectly in the performance of the services covering liability for bodily injury, death and damage to property with a limit of not less than \$2,000,000. inclusive for each and every loss.

Environmental Impairment Liability (if applicable)

The Contractor shall effect and maintain Environmental Impairment Liability with a limit of not less than \$2,000,000. Per Incident /Annual Aggregate. Coverage shall include Third Party Bodily Injury and Property Damage including on-site and off-site clean-up. Coverage shall not be limited to sudden and accidental and contain no exclusion for mould or microbial matter. If such insurance is issued on a claims made basis, such insurance shall be maintained for a period of two years subsequent to conclusion of services provided under this Agreement.

Such insurance shall add the United Counties of Prescott Russell and the landowner as Additional Insured with respect to the operations of the contractor. This insurance shall be non-contributing with and apply as primary and not as excess of any insurance available to the Counties and/or landowner. The contractor shall indemnify and hold United Counties of Prescott Russell and the landowner harmless from and against any liability, loss, claims, demands, costs and expenses, including reasonable legal fees, occasioned wholly or in part by any negligence or acts or omissions whether willful or otherwise by the contractor, their officers, employees or other persons for whom they are legally responsible.

The above noted policies shall not be cancelled, altered or lapsed unless the Insurer notifies the Counties in writing at least thirty (30) days prior to the effective date of the change or cancellation.

Prior to commencement of work, the landowner and / or contractor shall furnish to the Counties with a certificate of insurance or copies of the policies confirming the aforementioned insurance. The insurance policy will be in a form and with a company which are, in all respects, acceptable to the Counties.

Schedule B to By-law 2023-21

Minimum Requirements for location of entrances

(This Schedule does not apply for entranceways within the Township of East Hawkesbury)

Classification of entrance	Requirements
Agricultural/ Farm / Field / or for harvesting crop	<ul style="list-style-type: none"> a) If a non-County public road allowance is not available to provide an entrance; b) If on a major collector or Arterial road as identified in the Counties Official Plan, not within 200 metres of any entrance on the same side of the road or/and from any intersection or/and from a public entrance; c) If on a minor collector as identified in the Counties Official Plan, not within 100 metres of any entrance on the same side of the road or/and from any intersection or/and from a public entrance; d) Not within 50 metres of upon or across a day lighting triangle, acceleration, deceleration or passing lane; e) Not within 50 meters of a structure such as bridges that may obstruct the vision of traffic using an adjacent entrance and traffic on the County Road approaching the entrance. f) The sight distance equals or exceeds the distances as contained in the Minimum Sight Distance Table (1) which is contained in the schedule appended hereto as Schedule C. g) A Farm Entrance or Field Entrance shall only be permitted for a property where the agricultural activity takes place over an area of five or more hectares or in such other circumstances deemed appropriate by the Director. h) The location of the entrance shall conform to the local municipality's entrance policy and/or by-law.
Rural Residential	<ul style="list-style-type: none"> a) If a non-County public road allowance is not available to provide an entrance; b) If on a major collector or Arterial road as identified in the Counties Official Plan, not within 200 metres of any entrance on the same side of the road or/and from any intersection or/and from a public entrance; c) If on a minor collector as identified in the Counties Official Plan, not within 50 metres of any entrance on the same side of the road or/and from any intersection or/and from any public entrance with

	<p>the exception of County Roads 4, 24, 26 and 10 east of St-Eugène where not within 45 metres of any entrance on the same side of the road;</p> <ul style="list-style-type: none"> d) Not within 50 metres of upon or across a day lighting triangle, acceleration, deceleration or passing lane; e) Not within 50 meters of a structure such as bridges that may obstruct the vision of traffic using an adjacent entrance and traffic on the County Road approaching the entrance. f) The sight distance equals or exceeds the distances as contained in the Minimum Sight Distance Table (1) which is contained in the schedule appended hereto as Schedule C. g) The location of the entrance shall conform to the local municipality's entrance policy and/or by-law.
<p>Rural Commercial</p>	<ul style="list-style-type: none"> a) If a non-County public road allowance is not available to provide an entrance; b) If on a major collector or Arterial road as defined in the Counties Official Plan, not within 200 metres of any entrance on the same side of the road or/and from any intersection or/and from a public entrance; c) If on a minor collector as defined in the Counties Official Plan, not within 100 metres of any entrance on the same side of the road or/and from any intersection or/and from a public entrance; d) Not within 50 metres of upon or across a day lighting triangle, acceleration, deceleration or passing lane; e) Not within 50 meters of a structure such as bridges that may obstruct the vision of traffic using an adjacent entrance and traffic on the County Road approaching the entrance f) If the sight distance equals or exceeds the distances as contained in the Minimum Sight Distance Table (1) which is contained in the schedule appended hereto as Schedule C; g) If the sight distance equals or exceeds the distances as contained in the Minimum Sight Distance Table (2) which is contained in the schedule appended hereto as Schedule C; h) If the horizontal curvature of the County Road is greater than 500 metres; i) The County Road Grade is 3% or less. j) The location of the entrance shall conform to the local municipality's entrance policy and/or by-law.

<p>Urban Residential, Built-Up areas and Urban Agricultural/Farm/Field, and Urban Commercial</p>	<ul style="list-style-type: none"> a) On urban road sections, in towns, villages, hamlets and settlement areas, one entrance per lot shall be permitted. The location of the entrance shall conform to the local municipality's entrance policy and/or by-law. In the absence of such a policy and/or by-law, the distance between adjacent Residential Entrances shall be no less than the distance between existing entrances on the urban road section. b) Unless otherwise specified under a local municipality's entrance policy and/or by-law, the distance between adjacent Residential Entrances shall not be applicable to entrances providing access to semi-detached dwellings. c) In built-up areas that are not designated as towns, villages, hamlets or settlement areas, Residential Entrances will be permitted only where the need for the entrance is as a result of "in-filling" and the mandatory road safety criteria are met. In any case only one entrance per lot shall be permitted. d) Non-agricultural entrances which extend the limits of existing urban or built-up areas shall not be permitted.
---	--

Note: The most restrictive criteria will dictate if an entrance can be permitted and if so the location of the entrance

Schedule C to By-law 2023-21

Minimum Sight Distance

(This Schedule does not apply for entranceways within the Township of East Hawkesbury)

MINIMUM SIGHT DISTANCE TABLE (1) - RESIDENTIAL

Speed Limit km/h	Sight Distance for flat grade less than 3% (metres)	Sight Distance on a grade of 3% or greater (metres)
40	45	45
50	65	65
60	85	90
70	110	120
80	140	155
90	170	190
100	200	220

MINIMUM SIGHT DISTANCE TABLE (2) – COMMERCIAL/AGRICULTURAL

Speed Limit (km/h)	Sight Distance (metres)
50	120
60	140
70	160
80	180
90	200
100	230

Schedule D to By-law 2023-21

General requirements for entrance and front yard ditch filling

The diameter, gauge, length and type of culvert to be used to convey surface water drainage either through an entrance or a front yard ditch filling shall be determined by the County with the minimum size of culverts to no less than 450 mm in diameter and 9 meters in length. A larger size culvert may be required depending on the contributing drainage area, as determined by the Director. Side slopes shall be no steeper than ratio of 2 (horizontal) to 1 (vertical).

Only new standard corrugated steel pipe with a minimum wall thickness of 1.6 mm for pipes size up to 1,200 mm or high-density polyethylene (HDPE) materials 320 kpa for entrances and 210 kpa for front yard ditch filling; approved by the Director shall be used. The wall thickness for corrugated steel pipes with a larger diameter than 1,200 mm shall be evaluated on a case by case basis.

Culverts shall be installed at the proper grade so as to provide free and unimpeded flow of water through the culverts. The culvert shall be centred on the entrance and in the ditch line unless otherwise approved by the Director. The invert of the culvert must be set plus or minus 150 mm below the existing ditch grade.

The entranceway construction will be substantially completed when the work has been completed in conformance with County Standards, to the satisfaction of the Director and when the surface of the entrance is covered with a minimum granular "A" thickness of 150mm for granular entrance or finished with pavement, pavers or concrete for other finish type of entrance.

The front yard ditch filling construction will be substantially completed when the work has been completed in conformance with County Standards, to the satisfaction of the Director and when the surface of the front yard ditch filling has been covered with topsoil and when grass has grown. A front yard fill application could be denied if it implies a connection to a cross-culvert inlet or outlet that would cause restrictions in the maintenance or replacement of that cross-culvert.

Except for semi-detached dwelling located within an urban or built-up area, Residential entrance surface width shall be no wider than 7 metres. A Residential entrance for a semi-detached dwelling located within an urban or built-up area shall be no wider than 6 metres however in this specific case two entrances may be combined to form a 12m wide entrance. Commercial entrances surface shall be no wider than 9 metres unless otherwise approved by the Director. Agricultural, Farm and Field entrances surface shall be no wider than 12 metres. Field entrance for crop harvesting shall be no wider than 27 meters.

The use of water tanks, barrels, concrete blocks, concrete pipe, used corrugated steel pipe or used plastic pipe shall not be permitted.

Applicants shall acknowledge that they may be required to submit a site grading plan depicting the existing topography and the proposed site grades, spot elevations, swales, cross-sections etc., at the discretion of the Director.

Applicants shall acknowledge that they may be required to install catch basins, clean-outs, inlet and other structures as may be necessary to facilitate drainage from or alongside the road, at their cost. Only new manufactured components (grills, tees, catch-basins, manholes, couplers, etc.) of the exact same type and size as the pipes shall be used for the construction of the front yard fill and entrance.

Schedule E to By-law 2023-21

Please see attached UCPR standards drawings. The standard drawings may be amended from time to time at the discretion of the Director.

Entrance standard drawings

UCPR ENT-01-EN
UCPR ENT-01-FR

Front Yard Ditch Filling standard drawings

UCPR DF-01-EN
UCPR DF-01-FR

Work in right-of-way reinstatement standard drawings

UCPR RC-01-EN
UCPR RC-01-FR

UCPR RC-02-EN
UCPR RC-02-FR

UCPR RC-03-EN
UCPR RC-03-FR

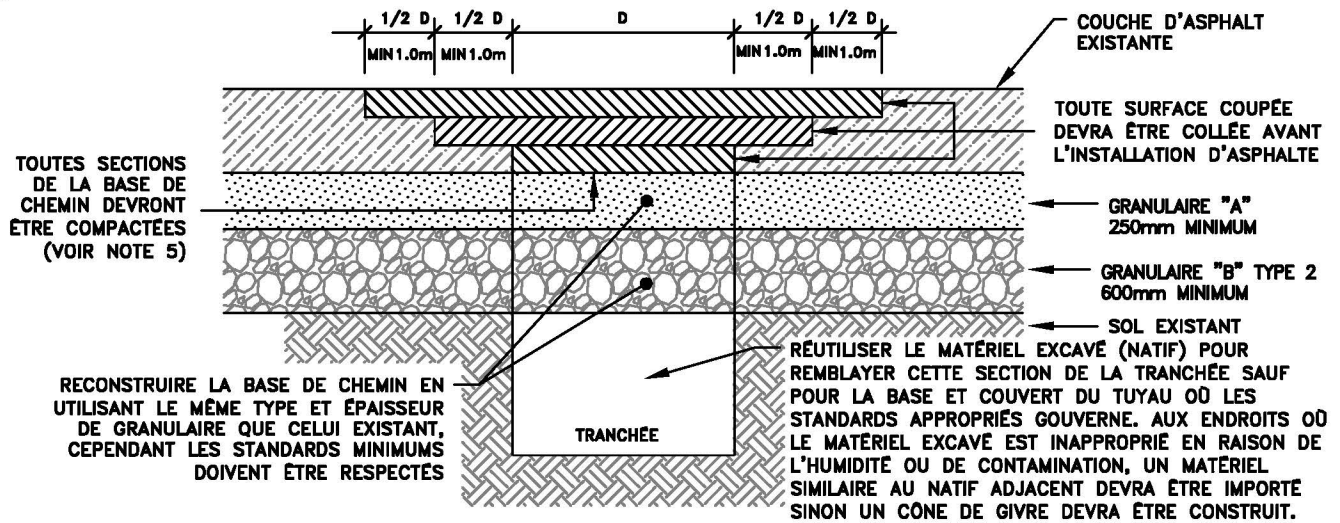

DÉTAIL DE RECONSTRUCTION DU CHEMIN (3 ÉPAISSEURS) ÉPAISSEUR DU PAVÉ > 100mm

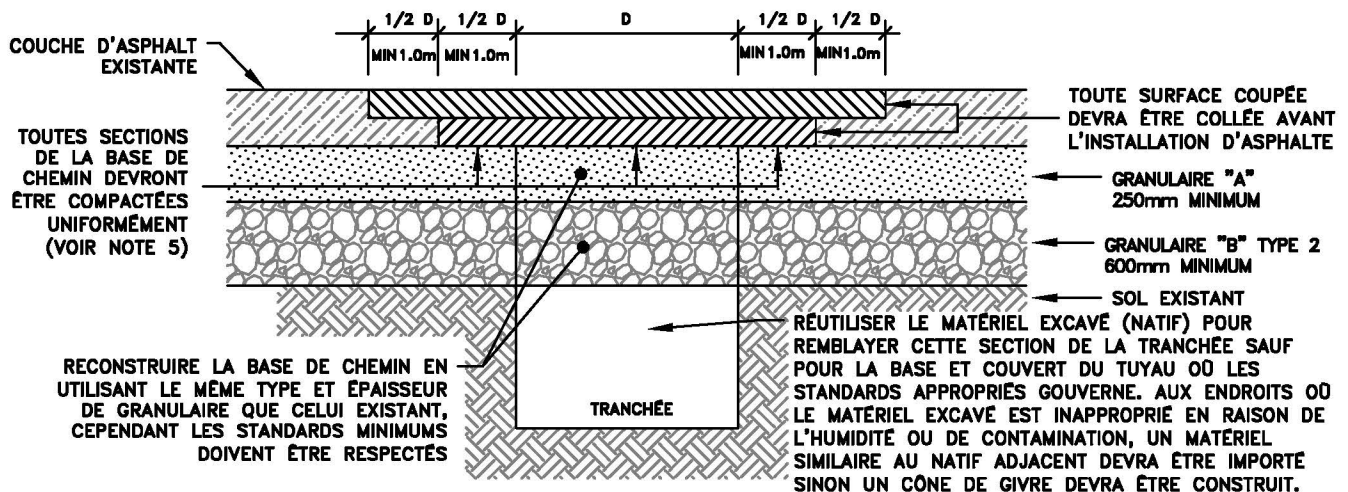

DÉTAIL DE RECONSTRUCTION DU CHEMIN (2 ÉPAISSEURS) 50mm < ÉPAISSEUR DU PAVÉ < 100mm

NOTES GÉNÉRALES:

1. TOUT PÉRIMÈTRE DE LA COUPURE DE CHEMIN DEVRA ÊTRE SCIÉ OU BROYÉ. UN JOINT DE TRANSITION EST REQUIS.
2. TOUT ASPHALTE INSTALLÉ DEVRA ÊTRE DE TYPE HL-4 ET DEVRA ÊTRE CONFORME AU OPSS MUNI 1150.
3. L'ASPHALTE DE QUALITÉ SUPÉRIEURE (PGAC) DEVRA ÊTRE PGAC 58-34 COMME STIPULÉ DANS LE OPSS MUNI 1101.
4. CHAQUE COUCHE D'ASPHALTE NE DEVRA PAS DÉPASSER 50mm D'ÉPAISSEUR.
5. CHAQUE COUCHE D'ASPHALTE ET DE REMBLAIS DEVRA RENCONTRER LES STANDARDS DE COMPACTION DU OPSS MUNI 310 ET OPSS MUNI 501.
6. LA SURFACE DEVRA ÊTRE LISSE ET SANS FISSURES.
7. LORSQUE LE JOINT DE TRANSITION LONGITUDINAL DE LA COUPE DE CHEMIN NE PEUT RENCONTRER LA MESURE MINIMALE DE "1/2 D" COMME DÉMONTRER CI-DESSUS, LA RECONSTRUCTION DU PAVÉ DEVRA S'ARRÊTER À L'UNE DES LIMITES SUIVANTES: LIGNE DE BORDURE DE LA ROUTE, LIGNE MÉDIANE DU CHEMIN, L'ÉPAULEMENT EN GRAVIER OU LA BORDURE DE BÉTON SI APPLICABLE. SE RÉFÉRER AU DESSIN TECHNIQUE UCPR-RC-03-FR POUR PLUS DE DÉTAILS.
8. LORSQUE LE JOINT DE TRANSITION LONGITUDINAL DE LA COUPE DE CHEMIN NE REJOINT PAS LES LIMITES MINIMALES COMME DÉMONTRÉ SUR LE DESSIN TECHNIQUE UCPR-RC-03-FR, LA PORTION MANQUANTE POUR SATISFAIRE CELLES-CI DEVRA ÊTRE PARTIELLEMENT BROYÉE (50mm) ET RÉTABLIE AVEC LA COUCHE DE SURFACE FINALE.
9. LE DÉTENTEUR DU PERMIS EST RESPONSABLE DE LA PERFORMANCE ADÉQUATE DE LA ZONE AFFECTÉE PAR LA COUPURE DE CHEMIN À LA SATISFACTION DES COMTÉS POUR UNE PÉRIODE DE DEUX (2) ANS À PARTIR DE LA DATE D'ACCEPTATION PRÉLIMINAIRE DES TRAVAUX.

Prescott
Russell

**STANDARD POUR COUPE DE
CHEMIN
(> 50mm ÉPAISSEUR DU PAVÉ)**

APPROUVÉ. PAR:
Pier-Luc Mainville
Ingénieur des Travaux Publics

DATE: Octobre 2021

DWG. No.:
UCPR RC-01-FR

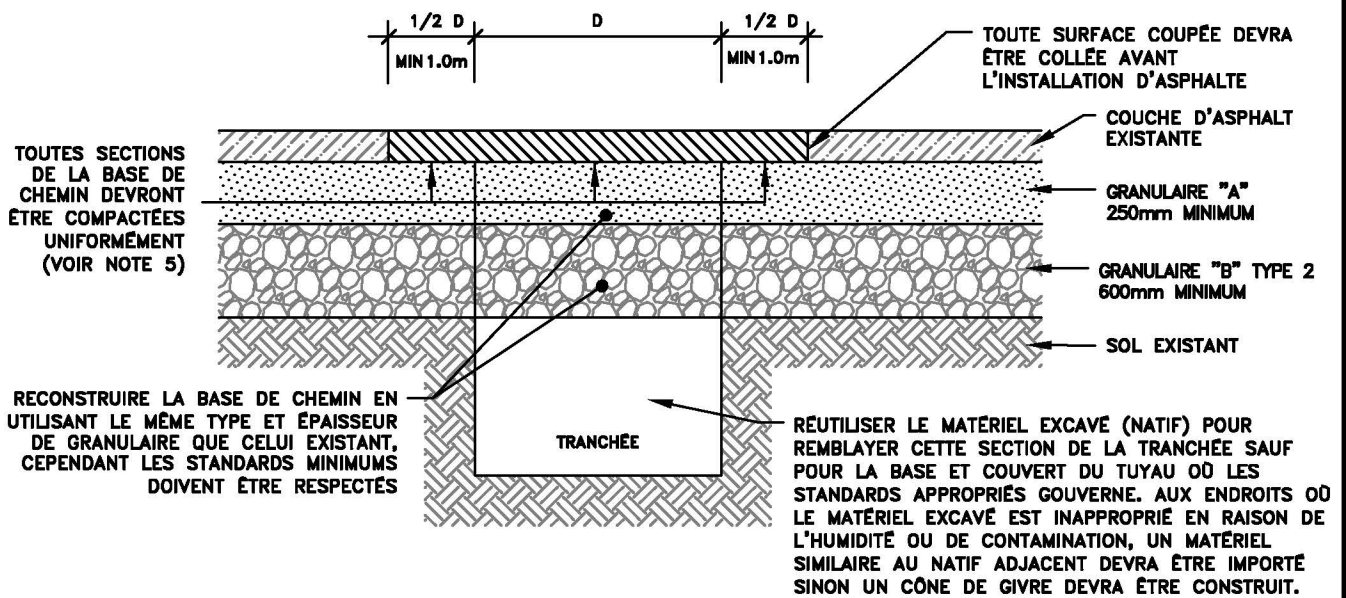

DÉTAIL DE RECONSTRUCTION DU CHEMIN PAVÉ (1 ÉPAISSEUR) ÉPAISSEUR DU PAVÉ < 50mm

NOTES GÉNÉRALES:

1. TOUT PÉRIMÈTRE DE LA COUPURE DE CHEMIN DEVRA ÊTRE SCIÉ OU BROYÉ. UN JOINT DE TRANSITION EST REQUIS.
2. TOUT ASPHALTE INSTALLÉ DEVRA ÊTRE DE TYPE HL-4 ET DEVRA ÊTRE CONFORME AU OPSS MUNI 1150.
3. L'ASPHALTE DE QUALITÉ SUPÉRIEURE (PGAC) DEVRA ÊTRE PGAC 58-34 COMME STIPULÉ DANS LE OPSS MUNI 1101.
4. CHAQUE COUCHE D'ASPHALTE NE DEVRA PAS DÉPASSER 50mm D'ÉPAISSEUR.
5. CHAQUE COUCHE D'ASPHALTE ET DE REMBLAIS DEVRA RENCONTRER LES STANDARDS DE COMPACTION DU OPSS MUNI 310 ET OPSS MUNI 501.
6. LA SURFACE DEVRA ÊTRE LISSE ET SANS FISSURES.
7. LORSQUE LE JOINT DE TRANSITION LONGITUDINAL DE LA COUPE DE CHEMIN NE PEUT RENCONTRER LA MESURE MINIMALE DE "1/2 D" COMME DÉMONTRER CI-DESSUS, LA RECONSTRUCTION DU PAVÉ DEVRA S'ARRÊTER À L'UNE DES LIMITES SUIVANTES: LIGNE DE BORDURE DE LA ROUTE, LIGNE MÉDIANE DU CHEMIN, L'ÉPAULEMENT EN GRAVIER OU LA BORDURE DE BÉTON SI APPLICABLE. SE RÉFÉRER AU DESSIN TECHNIQUE UCPR-RC-03-FR POUR PLUS DE DÉTAILS.
8. LORSQUE LE JOINT DE TRANSITION LONGITUDINAL DE LA COUPE DE CHEMIN NE REJOINT PAS LES LIMITES MINIMALES COMME DÉMONTRÉ SUR LE DESSIN TECHNIQUE UCPR-RC-03-FR, LA PORTION MANQUANTE POUR SATISFAIRE CELLES-CI DEVRA ÊTRE PARTIELLEMENT BROYÉE (50mm) ET RÉTABLIE AVEC LA COUCHE DE SURFACE FINALE.
9. LE DÉTENTEUR DU PERMIS EST RESPONSABLE DE LA PERFORMANCE ADÉQUATE DE LA ZONE AFFECTÉE PAR LA COUPURE DE CHEMIN À LA SATISFACTION DES COMTÉS POUR UNE PÉRIODE DE DEUX (2) ANS À PARTIR DE LA DATE D'ACCEPTATION PRÉLIMINAIRE DES TRAVAUX.

Prescott
Russell

**STANDARD POUR COUPE DE
CHEMIN
(ÉPAISSEUR DU PAVÉ < 50mm)**

APPROUVÉ. PAR:
Pier-Luc Mainville
Ingénieur des Travaux Publics

DATE: Octobre 2021

DWG. No.:
UCPR RC-02-FR

LÉGENDE



ZONE DE TRAVAIL



LIMITES MINIMALES DE RECONSTRUCTION

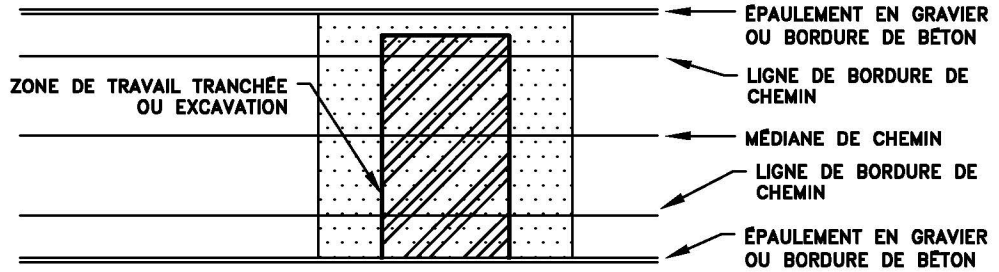

RECONSTRUCTION D'ASPHALTE POUR ZONE DE TRAVAIL TRAVERSANT LA LIGNE DE BORDURE OPPOSÉ

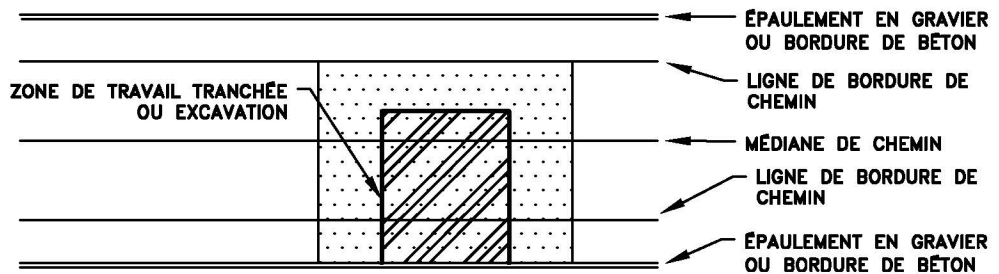

ONSTRUCTION D'ASPHALTE POUR ZONE DE TRAVAIL TRAVERSANT LA MÉDIANE DE CHEMIN

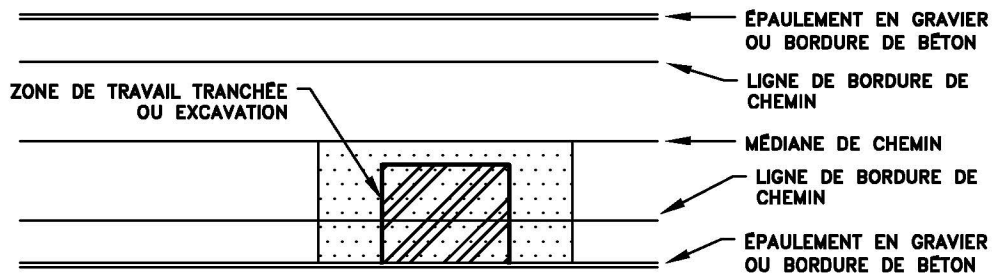

RECONSTRUCTION D'ASPHALTE POUR ZONE DE TRAVAIL TRAVERSANT LA LIGNE DE BORDURE

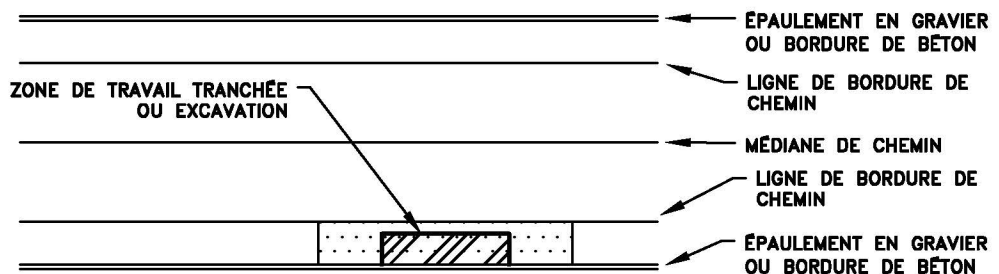

RECONSTRUCTION D'ASPHALTE POUR ZONE DE TRAVAIL ENTRE LA LIGNE DE BORDURE ET L'ÉPAULEMENT

NOTES GÉNÉRALES:

1. TOUTE RECONSTRUCTION DEVRONT ÊTRE CONFORME AUX STANDARDS DES COMTÉS UNIS DE PRESCOTT ET RUSSELL UCPR RC-01 ET UCPR RC-02
2. LE PROPRIÉTAIRE DOIT S'INFORMER AUPRÈS DE TOUS LES SERVICES PUBLICS AFIN DE DÉTERMINER OÙ SONT ENFOUIS LEURS SERVICES ET SERA RESPONSABLE S'ILS SONT ENDOMMAGÉS LORS DE LA CONSTRUCTION.



**STANDARD POUR
COUPE DE CHEMIN
(VUE EN PLAN)**

APPROUVÉ. PAR:
Pier-Luc Mainville
Ingénieur des Travaux Publics

DATE: Octobre 2021

DWG. No.: UCPR RC-03-FR

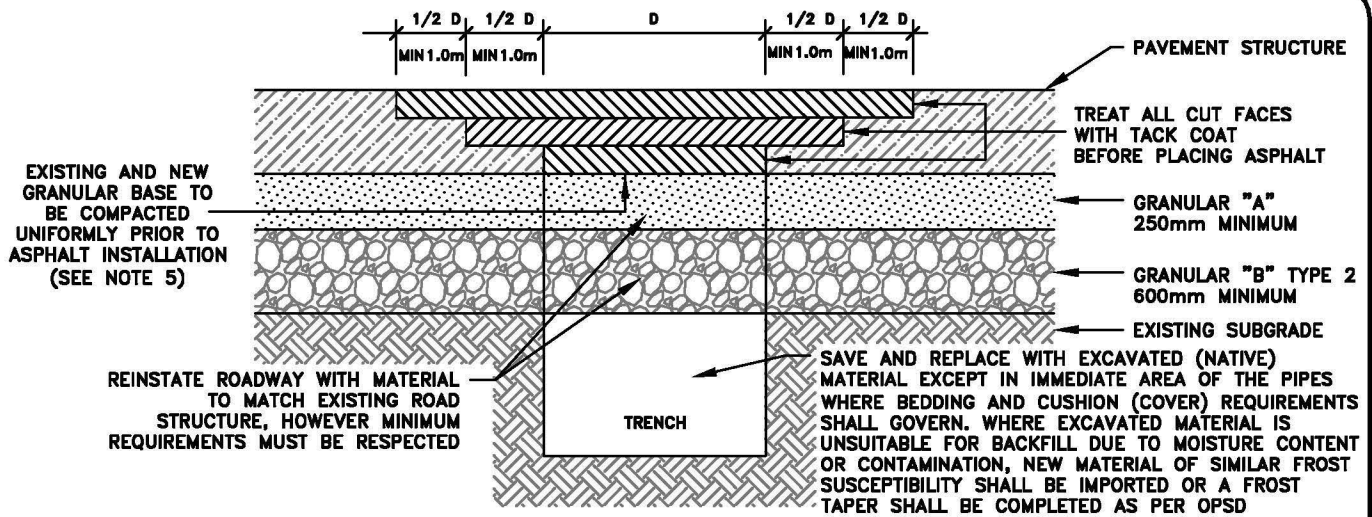

HOT MIX ASPHALT PAVEMENT REINSTATEMENT SECTION DETAIL - PAVEMENT DEPTH > 100mm (3 LIFTS)

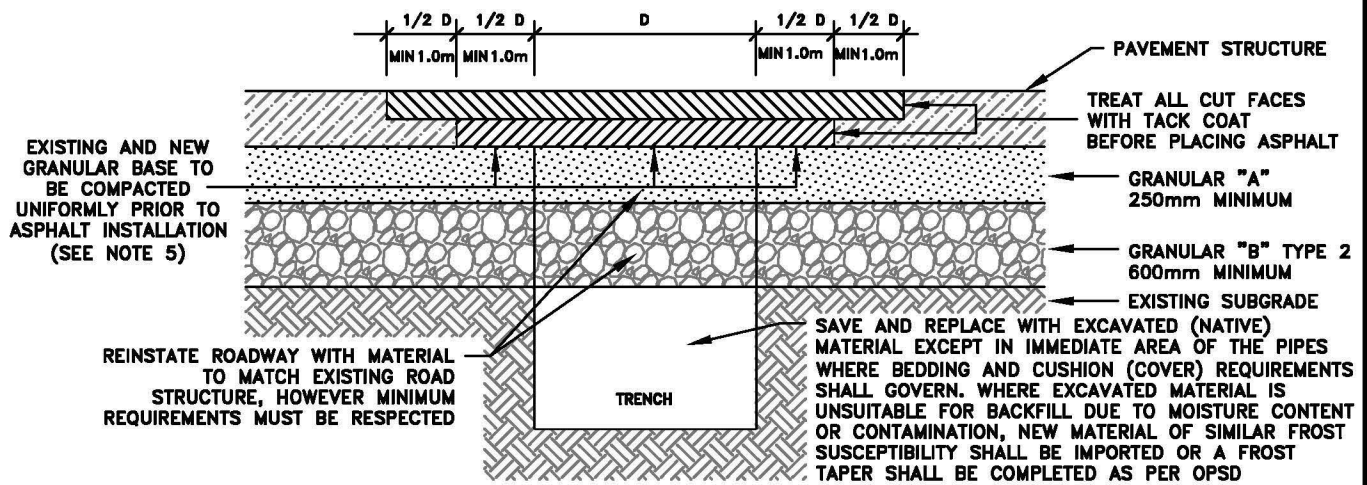

HOT MIX ASPHALT PAVEMENT REINSTATEMENT SECTION DETAIL - 50mm < PAVEMENT DEPTH < 100mm (2 LIFTS)

GENERAL NOTES:

1. ALL ROAD CUT EDGES WITHIN THE EXISTING ASPHALT PAVEMENT SHALL BE SAW CUT OR GRINDED TO PROVIDE A UNIFORM JOINT.
2. HOT MIX ASPHALT SHALL BE HL-4 AND SHALL CONFORM TO OPSS MUNI 1150.
3. PERFORMANCE GRADED ASPHALT CEMENT SHALL BE PGAC 58-34 AS PER OPSS.MUNI.1101.
4. EACH LAYERS OF ASPHALT PAVEMENT SHALL NOT EXCEED 50mm IN THICKNESS.
5. EACH LAYERS OF ASPHALT PAVEMENT AND BACKFILL SHALL MEET THE OPSS MUNI 310 AND OPSS MUNI 501 COMPACTION REQUIREMENTS.
6. THE ASPHALT WEAR COURSE SHALL BE SMOOTH, UNIFORM AND FREE FROM HAIR CHECKING.
7. ALL ASPHALT PAVEMENT JOINTS ARE TO BE TACK COATED PRIOR TO INSTALLATION OF ASPHALT.
8. WHERE THE ROAD CUT LONGITUDINAL STEP JOINT CANNOT MEET THE REQUIRED 1/2 D AS SHOWN ABOVE, THE PAVEMENT REINSTATEMENT SHALL END AT EITHER THE EDGE LINE, THE CENTER LINE OR AT THE CURB / SHOULDER, AS APPLICABLE. REFER TO DRAWING UCPR RC-03-EN FOR DETAILS.
9. WHERE THE ROAD CUT LONGITUDINAL JOINT (1/2 D) DOESN'T EXTEND TO THE MINIMAL REINSTATEMENT LIMITS AS IDENTIFIED IN NOTE 8 AND ON DRAWING UCPR RC-03-EN, THE UNTOUCHED OR LEFT-OVER PORTION OF PAVEMENT TO REACH THE MINIMAL LIMITS SHALL BE GRINDED AND RE-PAVED AS PART OF THE WEAR COURSE.
10. THE PERMIT HOLDER IS RESPONSIBLE FOR THE SATISFACTORY PERFORMANCE OF THE ROAD CUT REINSTATEMENT FOR A PERIOD OF TWO (2) CALENDAR YEARS FOLLOWING THE PRELIMINARY ACCEPTANCE DATE.



**STANDARD ROAD CUT
PAVEMENT REINSTATEMENT
(PAVEMENT DEPTH > 50mm)**

APPROVED BY:	Pier-Luc Mainville Public Works Engineer
DATE:	October 2021
DWG. No.:	UCPR RC-01-EN

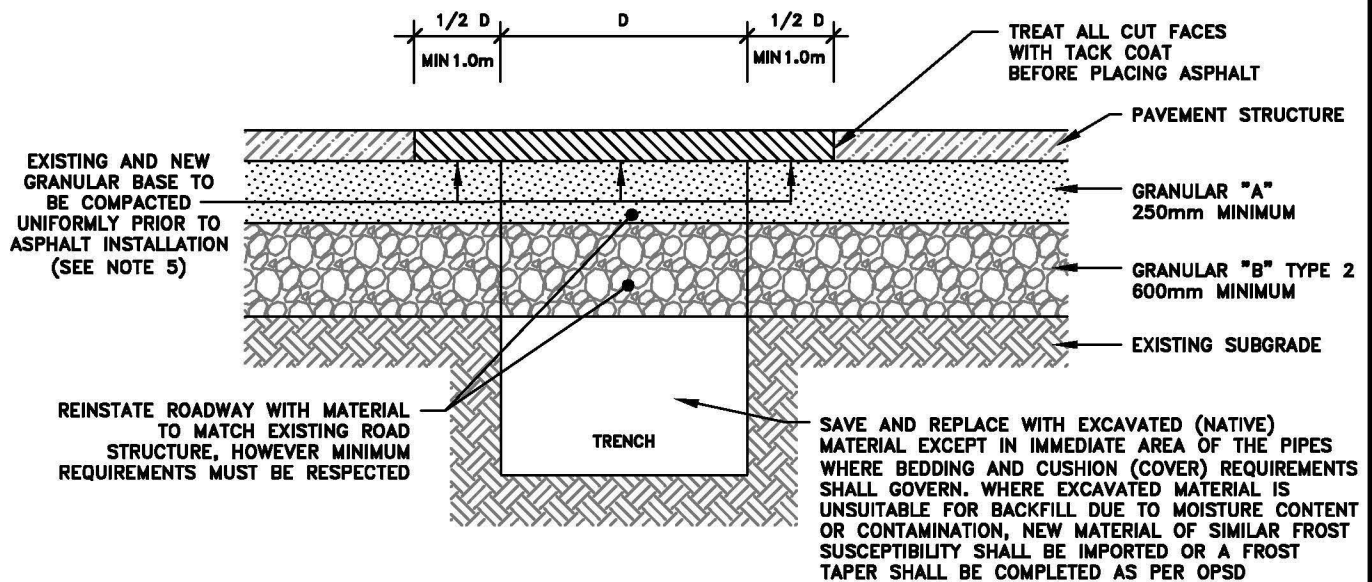

HOT MIX ASPHALT PAVEMENT REINSTATEMENT
SECTION DETAIL – PAVEMENT DEPTH < 50mm (1 LIFT)

GENERAL NOTES:

1. ALL ROAD CUT EDGES WITHIN THE EXISTING ASPHALT PAVEMENT SHALL BE SAW CUT OR GRINDED TO PROVIDE A UNIFORM JOINT.
2. HOT MIX ASPHALT SHALL BE HL-4 AND SHALL CONFORM TO OPSS MUNI 1150.
3. PERFORMANCE GRADED ASPHALT CEMENT SHALL BE PGAC 58-34 AS PER OPSS.MUNI.1101.
4. EACH LAYERS OF ASPHALT PAVEMENT SHALL NOT EXCEED 50mm IN THICKNESS.
5. EACH LAYERS OF ASPHALT PAVEMENT AND BACKFILL SHALL MEET THE OPSS MUNI 310 AND OPSS MUNI 501 COMPACTION REQUIREMENTS.
6. THE ASPHALT WEAR COURSE SHALL BE SMOOTH, UNIFORM AND FREE FROM HAIR CHECKING.
7. ALL ASPHALT PAVEMENT JOINTS ARE TO BE TACK COATED PRIOR TO INSTALLATION OF ASPHALT.
8. WHERE THE ROAD CUT LONGITUDINAL STEP JOINT CANNOT MEET THE REQUIRED $\frac{1}{2} D$ AS SHOWN ABOVE, THE PAVEMENT REINSTATEMENT SHALL END AT EITHER THE EDGE LINE, THE CENTER LINE OR AT THE CURB / SHOULDER, AS APPLICABLE. REFER TO DRAWING UCPR RC-03-EN FOR DETAILS.
9. WHERE THE ROAD CUT LONGITUDINAL JOINT ($\frac{1}{2} D$) DOESN'T EXTEND TO THE MINIMAL REINSTATEMENT LIMITS AS IDENTIFIED IN NOTE 8 AND ON DRAWING UCPR RC-03-EN, THE UNTOUCHED OR LEFT-OVER PORTION OF PAVEMENT TO REACH THE MINIMAL LIMITS SHALL BE GRINDED AND RE-PAVED AS PART OF THE WEAR COURSE.
10. THE PERMIT HOLDER IS RESPONSIBLE FOR THE SATISFACTORY PERFORMANCE OF THE ROAD CUT REINSTATEMENT FOR A PERIOD OF TWO (2) CALENDAR YEARS FOLLOWING THE PRELIMINARY ACCEPTANCE DATE.

Prescott
Russell

**STANDARD ROAD CUT
PAVEMENT REINSTATEMENT
(PAVEMENT DEPTH < 50mm)**

APPROVED. BY:
Pier-Luc Mainville
Public Works Engineer

DATE: October 2021

DWG. No.:
UCPR RC-02-EN

LEGEND

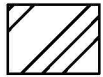

WORK AREA

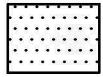

MINIMAL PATCH AREA

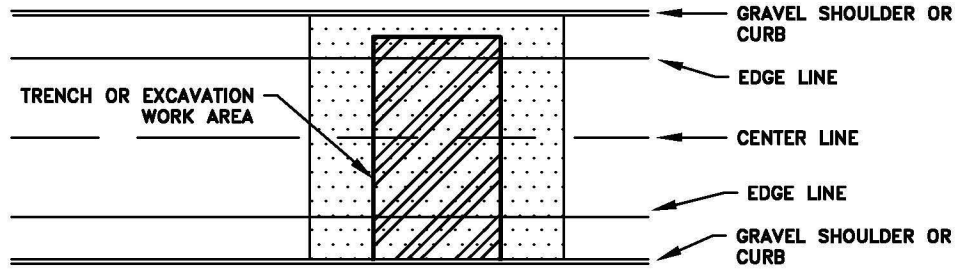

PATCH FOR WORK AREA CROSSING THE OPPOSITE EDGE LINE

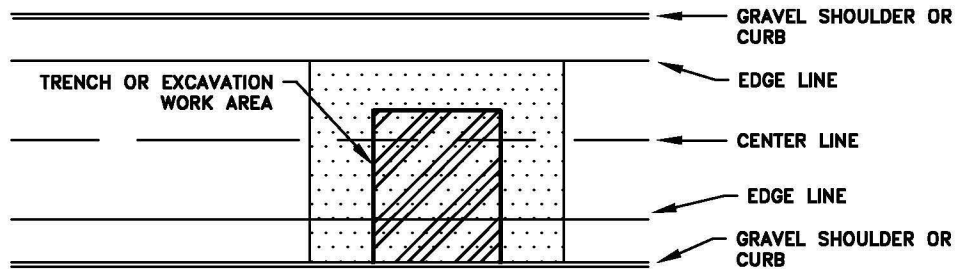

PATCH FOR WORK AREA CROSSING THE ROAD CENTER LINE

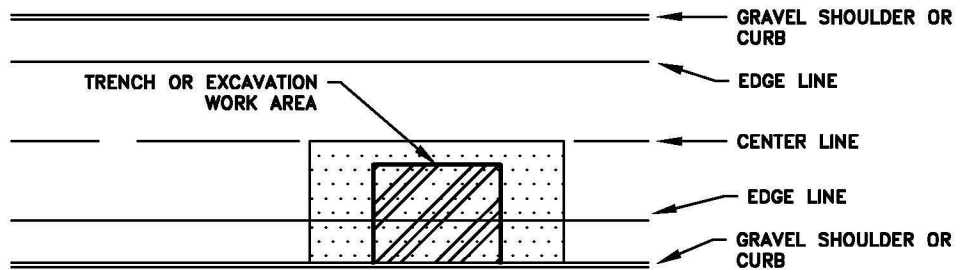

PATCH FOR WORK AREA CROSSING THE EDGE LINE

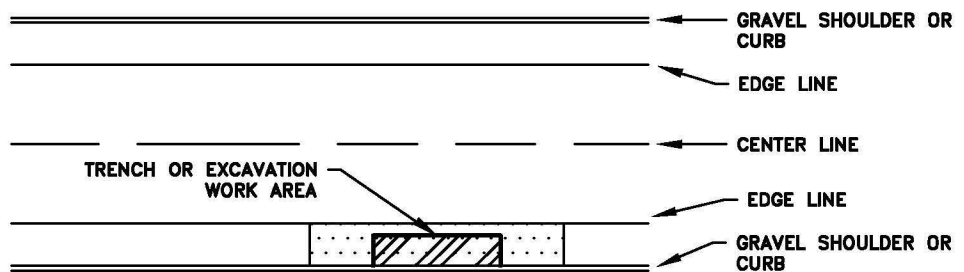

PATCH FOR WORK AREA BETWEEN EDGE LINE & GRAVEL SHOULDER

GENERAL NOTES:

1. ALL ROAD REINSTATEMENT SHALL BE DONE ACCORDING TO THE UNITED COUNTIES OF PRESCOTT AND RUSSELL DRAWINGS UCPR RC-01-EN AND UCPR RC-02-EN
2. THE OWNER MUST MAKE ARRANGEMENTS WITH THE UTILITY COMPAGNIES TO DETERMINE THE LOCATION OF ANY BURRIED SERVICES AND SHALL BE RESPONSIBLE FOR ANY DAMAGES.



**STANDARD ROAD CUT
REINSTATEMENT
(PLAN VIEW)**

APPROVED BY:
Pier-Luc Mainville
Public Works Engineer

DATE: October 2021

DWG. No.: **UCPR RC-03-EN**

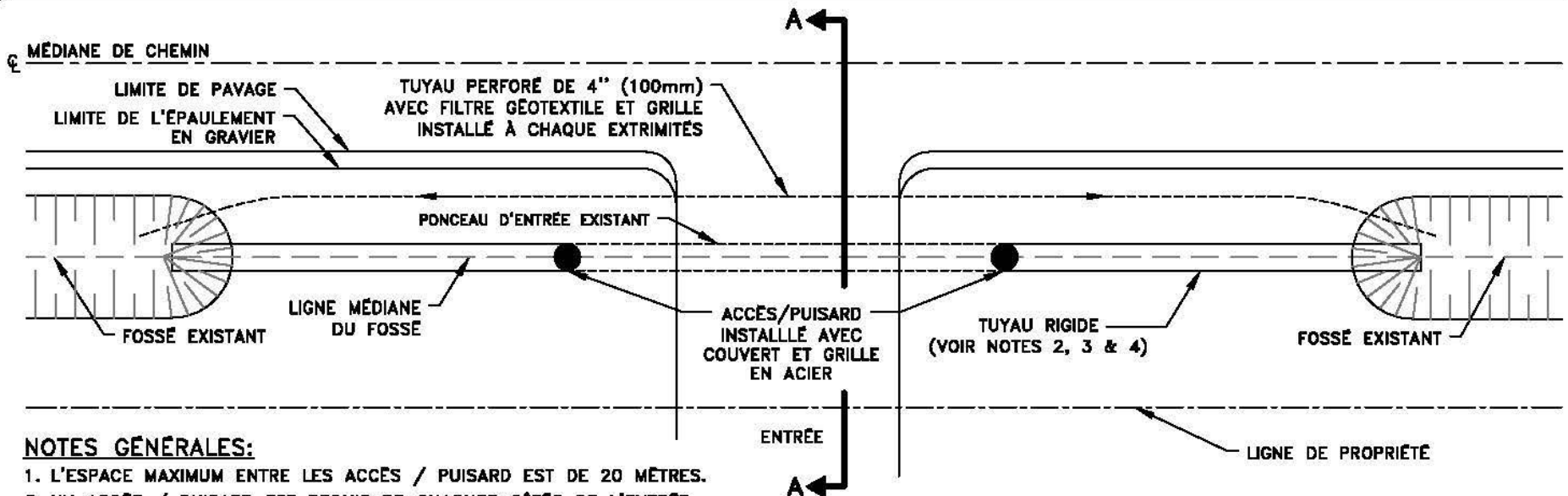

NOTES GÉNÉRALES:

1. L'ESPACE MAXIMUM ENTRE LES ACCÈS / PUISARD EST DE 20 MÈTRES.
2. UN ACCÈS / PUISARD EST REQUIS DE CHAQUES CÔTÉS DE L'ENTRÉE.
3. LES TYPES DE TUYAUX ACCEPTÉS POUR REMPLIR LE FOSSE SONT; LE POLYÉTHYLÈNE DE HAUTE DENSITÉ 210 kPa (PEHD) ET L'ACIER ONDULÉ GALVANISÉ. LE DIAMÈTRE DU TUYAU AINSI QUE L'ÉPAISSEUR DE LA PAROI SERONT DÉTERMINÉS PAR L'INSPECTEUR DES COMTÉS.
4. LE PROPRIÉTAIRE DOIT CONTACTÉ LE DÉPARTEMENT DES TRAVAUX PUBLICS DES CUPR AFIN D'OBTENIR UN PERMIT AVANT DE DÉBUTÉ TOUTE CONSTRUCTION DANS L'EMPRISE DE CHEMIN. LE PROPRIÉTAIRE EST RESPONSABLE DE TOUS LES COÛTS ASSOCIÉ À L'ACHAT DE TOUT LES MATÉRIAUX ET LA CONSTRUCTION DU REMPLISSAGE DE FOSSE.
5. LE FOSSE EXISTANT DOIT ÊTRE EXCAVÉ / NETTOYÉ AINSI QU'AVOIR UN GRADIENT CONVENABLE AU DRAINAGE DU FOSSE AVANT L'INSTALLATION DU NOUVEAU TUYAU.
9. LE PROPRIÉTAIRE EST RESPONSABLE DE FAIRE DEMANDE AUPRÈS DES COMPAGNIES D'UTILITÉS AINSI QUE LES AUTORITÉS PUBLIQUES POUR LOCALISER LES INFRASTRUCTURES EXISTANTES DANS L'ÉTENDUE DES TRAVAUX. LE PROPRIÉTAIRE SERA TENU RESPONSABLE POUR TOUT DOMMAGE À CES INFRASTRUCTURES CAUSÉ PAR LA CONSTRUCTION DES TRAVAUX.
10. UN TUYAU PERFORÉ DE 100mm EN PLASTIC DOIT ÊTRE INSTALLÉ LE LONG DU CHEMIN COMME INDIQUÉ SUR LE DESSIN CI-DESSUS. CE TUYAU SERA PLACÉ À ENVIRON 1 MÈTRE DE LA SURFACE ASPHALTÉ ET A UNE PROFONDEUR MAXIMALE DE 0.6 MÈTRE SOUS CHEMIN. LE CHEMIN DEVRA ÊTRE RÉTABLI AUX CONDITIONS ORIGINALES ET À LA SATISFACTION DES COMTÉS.
11. DANS LE CAS OÙ LA DEVANTURE DE LA PROPRIÉTÉ CROISE UNE TRAVERSE DE CHEMIN EXISTANTE, LE PROPRIÉTAIRE DOIT INSTALLER UN REGARD À L'INTERSECTION DE LA TRAVERSE ET DU NOUVEAU TUYAU DANS LE FOSSE SELON LES SPÉCIFICATION DÉTERMINÉ PAR LES TRAVAUX PUBLIC DES COMTÉS. CE REGARD DEVRA ÊTRE TAILLÉ POUR ACCEPTER LE TUYAU EXISTANT AINSI QUE LE DÉBIT ASSOCIÉ À CELUI-CI.
12. TOUS TRAVAUX NON AUTORISÉS OU QUI NE RENCONTRE PAS LES NORMES DU DÉPARTEMENT DES TRAVAUX PUBLICS DES CUPR SERONT ENLEVÉS AUX FRAIS DU PROPRIÉTAIRE.

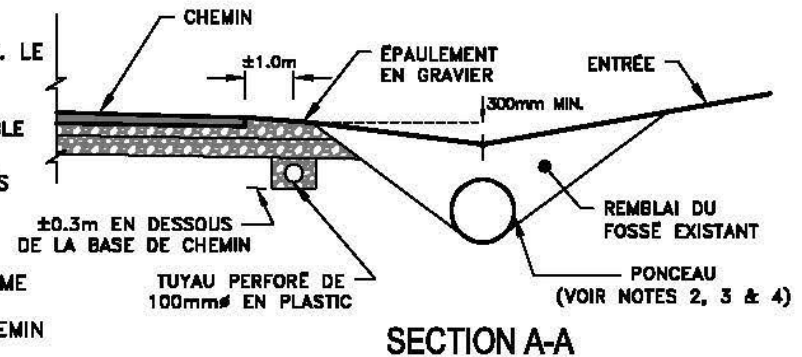

Prescott
Russell

DÉTAIL POUR REMPLISSAGE DE FOSSE

APPROUVÉ PAR:
Pier-Luc Mainville
Ingénieur des Travaux Publics

DATE: Octobre 2021

DWG. No.:
UCPR DF-01-FR

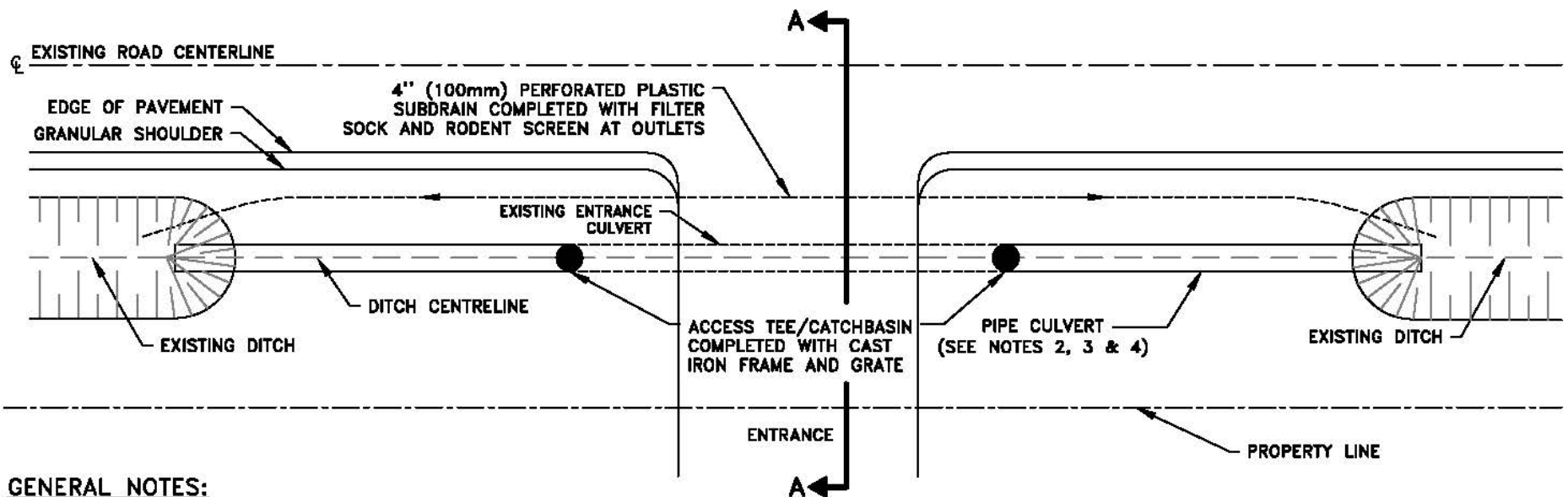

GENERAL NOTES:

1. 20 METRES MAXIMUM SPACING BETWEEN ACCESS TEES / CATCHBASINS.
2. AN ACCESS TEE / CATCHBASIN IS REQUIRED ON BOTH SIDES OF THE ENTRANCE.
3. PIPE CULVERT TO BE NEW GALVANIZED CORRUGATED STEEL PIPE OR 210 kPa, SIZE AND WALL THICKNESS TO BE DETERMINED BY THE COUNTIES
4. THE OWNER MUST CONTACT THE UCPR PUBLIC WORKS DEPARTMENT AND OBTAIN A PERMIT PRIOR TO ANY COMMENCEMENT OF WORKS. THE OWNER IS RESPONSIBLE FOR ALL COSTS ASSOCIATED WITH THE PURCHASE OF MATERIAL AND CONSTRUCTION OF THE DITCH FILL.
5. THE DITCH MUST BE CLEANED AND SLOPED PROPERLY BEFORE ANY INSTALLATION OF PIPES.
9. THE OWNER MUST MAKE ARRANGEMENTS WITH UTILITY COMPANIES AND PUBLIC SERVICES TO DETERMINE THE LOCATION OF ANY BURIED SERVICES AND SHALL BE RESPONSIBLE FOR ANY DAMAGES.
10. A 100mm PERFORATED PLASTIC PIPE COMPLETED WITH A FILTER CLOTH MUST BE BURIED IN THE ROADSIDE SHOULDER AT A MAXIMUM DEPTH OF 0.60 METRES. THE ROADSIDE SHOULDER SHALL BE RESTORED TO THE ORIGINAL CONDITION AND TO UCPR SATISFACTION.
11. IF THE DITCH FILLING WORKS INTERSECTS AN EXISTING COUNTY ROAD PIPE CROSSING, THE OWNER SHALL INSTALL A MAINTENANCE HOLE, AS DIRECTED BY THE COUNTIES, COMPLETED WITH A FRAME AND COVER AT THE JUNCTION. THE MAINTENANCE HOLE SHALL BE PROPERLY SIZED TO ACCEPT THE PIPE CROSSING.
12. ANY WORK UNAUTHORIZED OR ACCEPTED BY THE DEPARTMENT OF PUBLIC WORKS WILL BE REMOVED AT THE OWNER'S EXPENSE.

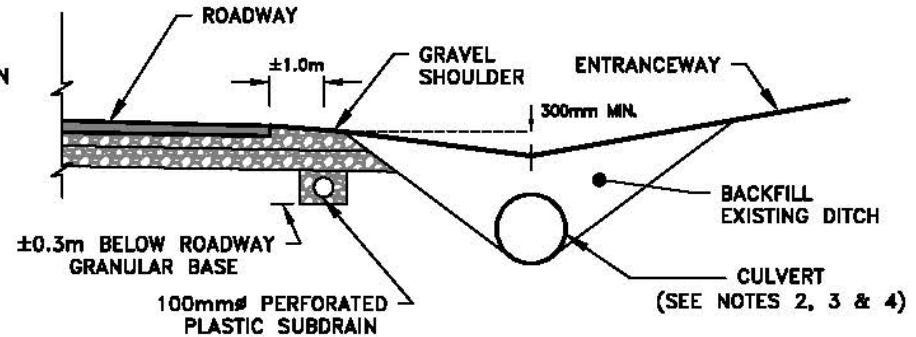

SECTION A-A

Prescott
Russell

DITCH FILLING

APPROVED BY:
Pier-Luc Mainville
Public Works Engineer

DATE: October 2021

DWG. No.:
UCPR DF-01-EN

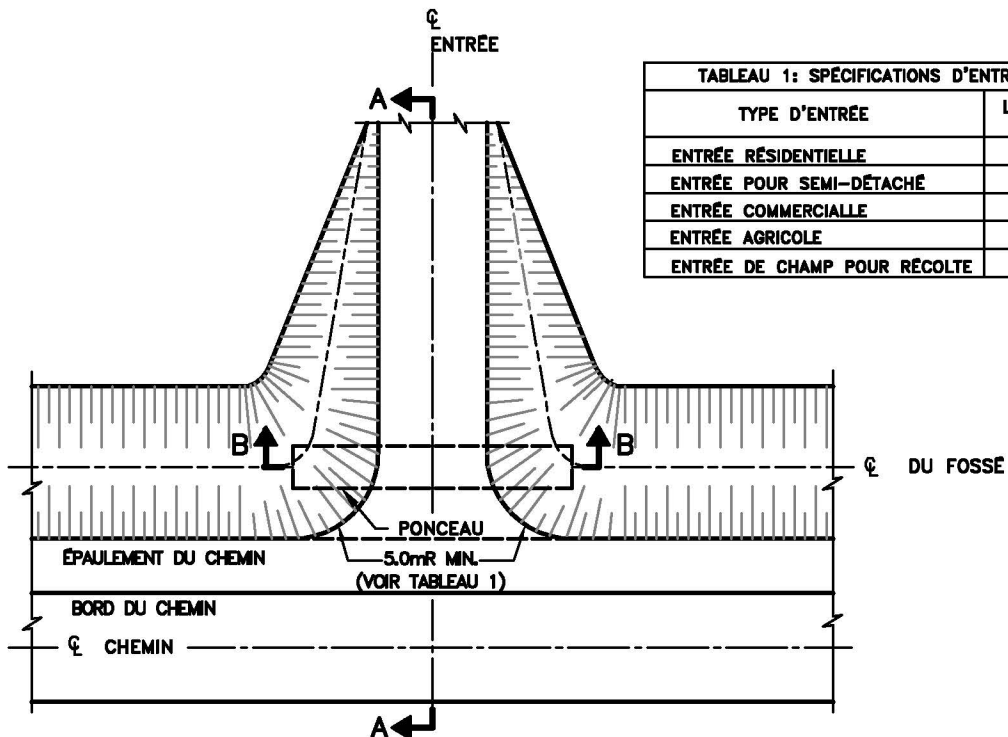

TYPE D'ENTRÉE	LARGEUR MAX.	RAYON D'ENTRÉE MIN.
ENTRÉE RÉSIDENNELLE	7m	5m
ENTRÉE POUR SEMI-DÉTACHÉ	6m	5m
ENTRÉE COMMERCIALE	9m	9m
ENTRÉE AGRICOLE	12m	12m
ENTRÉE DE CHAMP POUR RÉCOLTE	27m	12m

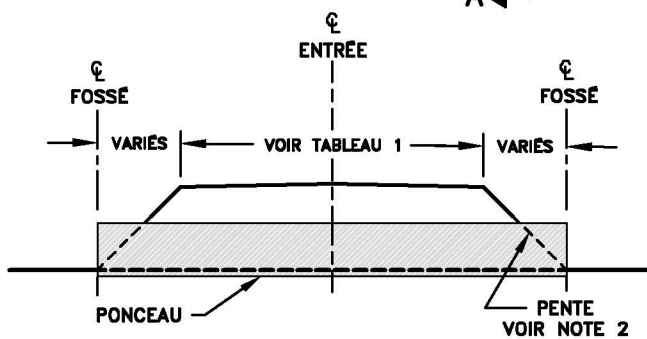

SECTION B-B

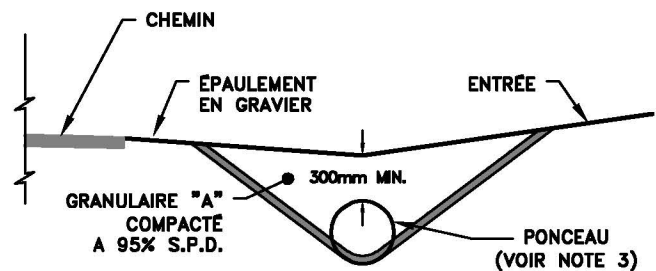

SECTION A-A

NOTES GÉNÉRALES:

1. SE RÉFÉRER AU STANDARD PROVINCIAL OPSS 350.010 & 351.010 POUR LES ENTRÉES DANS UN MILIEU URBAIN SANS FOSSÉ DE CHEMIN.
2. TOUTE PENTE LATÉRALE DU PONCEAU NE DEVRA PAS ÊTRE PLUS ABRUPTÉ QUE 2H:1V.
3. LE PONCEAU DEVRA ÊTRE INSTALLÉ 150mm SOUS L'ÉLÉVATION EXISTANTE DU FOND DU FOSSÉ.
4. LA PENTE MAXIMUM POUR UNE ENTRÉE EST 6% POUR UNE ENTRÉE RÉSIDENNELLE ET 10% POUR UNE ENTRÉE AGRICOLE OU DE CHAMPS POUR RÉCOLTE AGRICOLE.
5. LA CONSTRUCTION DE L'ENTRÉE DEVRA ÊTRE COMPLÉTÉE DANS UN DÉLAI TEL QU'IDENTIFIÉ SUR LE PERMIS. LA CONSTRUCTION DE L'ENTRÉE SERA CONSIDÉRÉE COMPLÈTE QUAND LA SURFACE DE L'ENTRÉE SERA COUVERTE D'UNE COUCHE MESURANT 150mm DE GRANULAIRE "A".
6. AVANT LA CONSTRUCTION, LE CONTREMAÎTRE DES TRAVAUX PUBLICS DES COMTÉS INSPECTERA LA LOCATION PROPOSÉE POUR L'ENTRÉE ET DÉTERMINERA LE DIAMÈTRE, LA LONGUEUR ET LA LOCATION DU PONCEAU. LE PROPRIÉTAIRE DU TERRAIN DEVRA INDICER AVEC DEUX (2) MARQUEURS PEINTURÉS LA LOCATION EXACTE DU PONCEAU PROPOSÉ. LE PROPRIÉTAIRE EST RESPONSABLE POUR LE CÔÛT TOTAL DE L'ACHAT ET L'INSTALLATION DU PONCEAU.
7. LE FOSSÉ DOIT ÊTRE NETTOYÉ DE TOUTES MATIÈRES ORGANIQUES ET DOIT AVOIR UNE PENTE APPROPRIÉE AVANT L'INSTALLATION DU TUYAU.
8. LE PROPRIÉTAIRE DOIT FAIRE TOUT ARRANGEMENT AVEC LES SERVICES PUBLICS ET COMPAGNIES D'UTILITÉS AFIN DE DÉTERMINER LA LOCATION DE LEURS SERVICES. LE PROPRIÉTAIRE EST RESPONSABLE DE TOUT DOMMAGE DURANT LA CONSTRUCTION.

Prescott
Russell

DÉTAIL POUR ENTRÉE

APPROUVÉ. PAR:
Pier-Luc Mainville
Ingénieur des Travaux Publics

DATE: Octobre 2021

DWG. No.:

UCPR ENT-01-FR

ENTRANCES TYPE	MAX. WIDTH	MIN. ENTRANCE RADIUS
RESIDENTIAL ENTRANCE	7m	5m
SEMI-DETACHED ENTRANCE	6m	5m
COMMERCIAL ENTRANCE	9m	9m
AGRICULTURE ENTRANCE	12m	12m
FIELD ENTRANCE	27m	12m

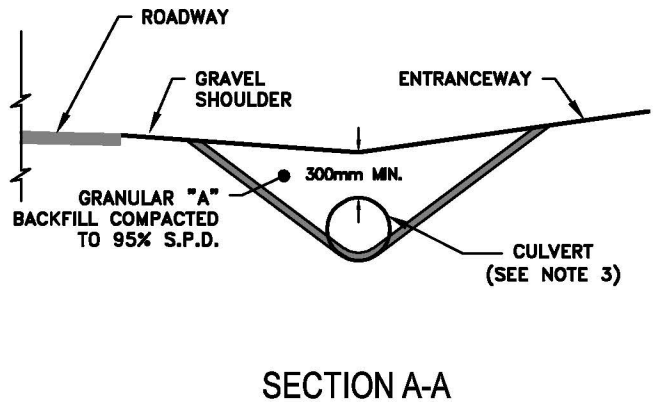
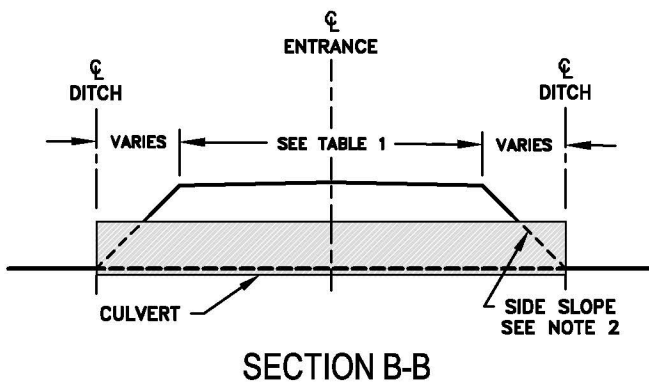
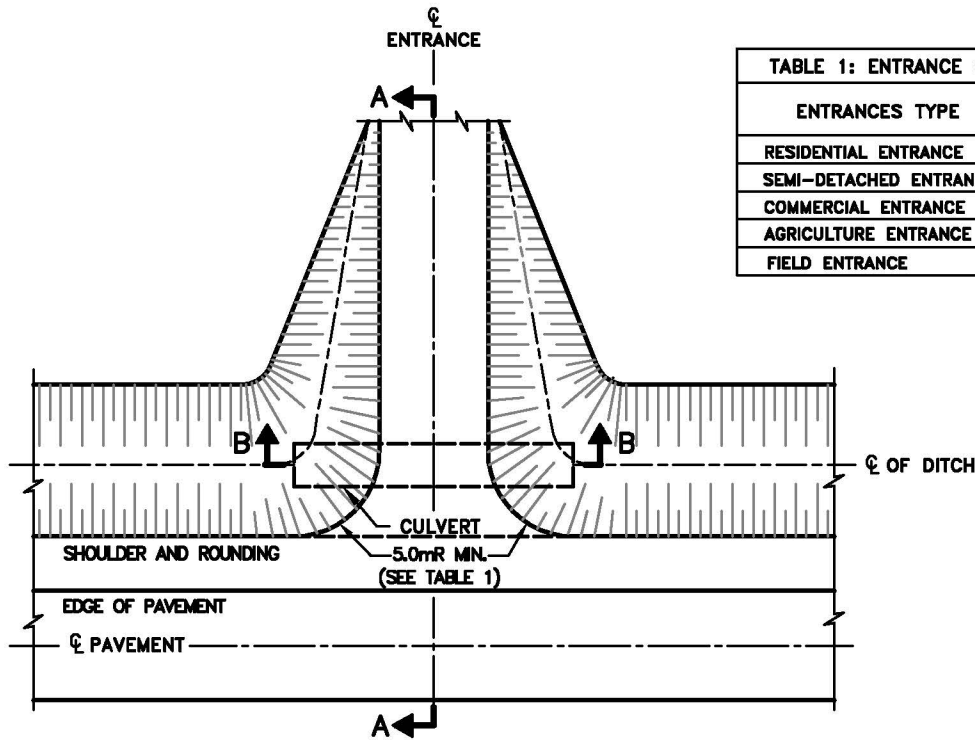

GENERAL NOTES:

1. REFER TO OPSD 350.010 & 351.010 FOR ENTRANCES IN URBAN AREAS WITHOUT ROADSIDE DITCHES.
2. SIDE SLOPES AT CULVERT SHALL BE NO STEEPER THAN 2H:1V.
3. THE CULVERT SHALL BE INSTALLED 150mm BELOW THE EXISTING BOTTOM OF DITCH ELEVATION.
4. THE MAXIMUM ENTRANCE GRADIENT IS 6% FOR RESIDENTIAL ENTRANCES AND 10% FOR FARM AND FIELD ENTRANCES.
5. THE ENTRANCEWAY CONSTRUCTION MUST BE COMPLETED WITHIN THE TIMEFRAME IDENTIFIED ON THE PERMIT. THE ENTRANCEWAY CONSTRUCTION WILL BE SUBSTANTIALLY COMPLETED WHEN THE SURFACE OF THE ENTRANCEWAY IS COVERED WITH A MINIMUM GRANULAR "A" THICKNESS OF 150mm.
6. PRIOR TO CONSTRUCTION, THE COUNTY'S PUBLIC WORKS FOREMAN WILL INSPECT THE PROPOSED ENTRANCE LOCATION AND DETERMINE THE SIZE, LENGTH AND LOCATION OF THE CULVERT. THE PROPERTY OWNER SHALL INDICATE WITH TWO (2) PAINTED WOODEN STAKES THE EXACT LOCATION OF THE PROPOSED CULVERT. THE OWNER IS RESPONSIBLE FOR ALL COSTS ASSOCIATED WITH THE PURCHASE AND INSTALLATION OF THE CULVERT, AS REQUIRED.
7. THE DITCH MUST BE CLEANED AND SLOPED PROPERLY BEFORE ANY PIPE IS INSTALLED.
8. THE OWNER MUST MAKE ARRANGEMENTS WITH UTILITY COMPANIES AND PUBLIC SERVICES TO DETERMINE THE LOCATION OF ANY BURIED SERVICES AND SHALL BE RESPONSIBLE FOR ANY DAMAGES.



ENTRANCE DRAWING

APPROVED BY:
 Pier-Luc Mainville
 Public Works Engineer

DATE: October 2021

DWG. No.:
UCPR ENT-01-EN