



City of Langford
www.cityoflangford.ca

Subdivision and Development Servicing Bylaw No. 1000

Consolidated to 17 March 2025

Table of Contents

Bylaw.....	i
List of Amendments.....	vii
Schedule 1	Procedures and Fees..... 1-1
	Table 1-1 Applications and Fees..... 1-7
Schedule 2	General requirements..... 2-1
Schedule 3	Earthworks..... 3-1
Schedule 4	Road Design and Construction..... 4-1
	Table 4-1 Road Classifications..... 4-2
	Table 4-2 Street Name Blade Replacement Requirements Standards 4-10
	Table 4-3 Road and Streetlighting Standards for Bear Mountain..... 4-17
Schedule 5	Storm Water Management..... 5-1
Schedule 6	Sewage Collection and Disposal 6-1
	Table 6-1 Sewage Flow Design Criteria 6-3
	Table 6-2 Population Equivalent Table 6-3
	Table 6-3 Main Pipe Parameters..... 6-3
	Table 6-4 Sewer Pipe and Fittings..... 6-3
	Table 6-5 Manhole Distance 6-4
Schedule 7	Sewage Lift Stations..... 7-1
	Table 7-1 Control Kiosk Specifications 7-8
	Table 7-2 Wiring Specifications for Control Kiosk..... 7-9
	Table 7-3 Digital Inputs for Control Kiosk 7-10
	Table 7-4 Digital Outputs for Control Kiosk 7-11
	Table 7-5 Analog Inputs for Control Kiosk..... 7-11
	Table 7-6 Conductor Color Code for Control Wiring..... 7-16
	Table 7-7 Control Wiring Labelling Conventions..... 7-16
	Table 7-8 Terminal Block Part List..... 7-16
Schedule 8	Water Supply 8-1
Schedule 9	Electricity and Telecommunications..... 9-1
Schedule 10	Irrigation Standards 10-1
	Table 10-1 Inspection Requirements 10-6
Schedule 11	Supplements to MMCD..... 11-1
Schedule 12	Drafting Standards 12-1
Schedule 13	Parks and Trails Construction 13-1
	Table 13-1 Design Criteria and Standards for Trail Width and Surfacing..... 13-1
	Table 13-2 Trail Gradient Standards 13-2
	Table 13-3 Trail Construction Standards..... 13-2
Schedule 14	Boulevard Landscape Standards..... 14-1
	Table 14-1 Tree Replacement 14-5
	Table 14-2 Artificial Turf Product Specification 14-6
	Table 14-3 Soil depth requirements..... 14-8
Schedule 15	Schedule 15..... 15-1

CITY OF LANGFORD
Subdivision, Development and Servicing Bylaw Number No. 1000

WHEREAS Council may appoint a person to be called an Approving Officer to exercise the jurisdiction conferred on him by the *Land Title Act* or the regulations or any other Act or regulations;

AND WHEREAS the Approving Officer appointed by the City of Langford has established procedures for examining proposed subdivisions which information is available to the public;

AND WHEREAS the Council may by bylaw impose subdivision application fees pursuant to Section 931 of the *Local Government Act*;

AND WHEREAS Council may by bylaw regulate and require the provision of works and services in respect of the subdivision or development of land, pursuant to Section 938 of the *Local Government Act*;

NOW THEREFORE the Council of the City of Langford in open meeting assembled enacts as follows:

1.0 TITLE

1.1 This Bylaw may be cited as the “Langford Subdivision and Development Servicing Bylaw No. 1000, 2009”.

2.0 APPLICATION

2.1 The provisions of this Bylaw apply to all lands within the area incorporated as the City of Langford. This Bylaw does not apply to any subdivision or building permit for which application was made prior to the date of coming into force of this Bylaw provided that such application is completed within 12 months of adoption of Bylaw 1000.

2.2 The purpose of this Bylaw is to regulate the subdivision and development of land and the arrangement, design and construction of highways, works and services, in order to:

- (a) Promote orderly, efficient, economical and aesthetically pleasing development.
- (b) Ensure that subdivisions and developments are developed in harmony with the environment and are suited to the use for which they are intended.

2.3 This Bylaw should be used in conjunction with the Schedules to this bylaw, Langford Zoning Bylaw, 1999 (No. 300) and the Langford Official Community Plan Bylaw, 2008 (No. 1200). Users of this Bylaw are advised that they should also be knowledgeable of the requirements of other applicable enactments including without limitation the:

- (a) *Land Title Act*;
- (b) *Local Government Act*;
- (c) *Community Charter*
- (d) *Strata Property Act* and Bare Land Strata Regulations;
- (e) *Agricultural Land Commission Act*;

- (f) *Real Estate Act;*
- (g) *Land Survey Act;*
- (h) *Forest Land Reserve Act;*
- (i) *Waste Management Act;*
- (j) *Highway Act;*
- (k) *Builders Lien Act;*
- (l) *Water Act.*

2.4 As a condition of

- a) The approval of a subdivision, or
- b) The issuance of a Building Permit

The owner of the land is required to provide works and services in accordance with the standards established in this bylaw, on that portion of a highway immediately adjacent to the site being subdivided or developed, up to the center line of the highway

3.0 SEVERABILITY

3.1 No provision of this Bylaw depends for its validity on any other provision and if any section, subsection, clause, sub-clause or phase of this Bylaw is for any reason held to be invalid by the decision of any court of competent jurisdiction, such decision shall not affect the validity of the remaining portions of this Bylaw.

4.0 DEFINITIONS

In this Bylaw,

Deleted. (Bylaw No. 1494)

“Acceptance of Substantial Performance” means the Director of Engineering’s acceptance in writing of the Engineer of Record’s issuance of Substantial Performance of the approved Works and Services as defined by the Master Municipal Construction Documents (MMCD) (latest edition). (Bylaw No. 1669)

“Applicant” means a person applying for approval of a subdivision or development, whether as the owner or as agent for the owner.

“Approved Product List” means the product list established by the City Engineer from time to time for the purposes of this Bylaw. (Bylaw No. 1817)

“Approving Officer” means the Approving Officer appointed pursuant to the *Land Title Act* for the City of Langford.

“Blast or Blasting” means the use of explosives for the purpose of moving, displacing or breaking rock or other material;

“Blaster” means the person, firm or corporation engaged by the Owner to conduct Blasting and includes an agent, contractor or employee of the Blaster;

“Boundary Adjustment” means an adjustment in existing boundaries between legally defined parcels of land that does not create additional parcels.

“Building Code” means the British Columbia Building Code, latest edition.

“Cal” or “caliper” means the diameter of the tree trunk measured 15 cm from the ground level or from the top of the root ball in the case of a tree grown in a nursery. (Bylaw No. 1494)

“Capital Regional District Water Services (CRDWS)” includes any organization assuming the responsibility for the retail water supply in Langford.

“City” means the City of Langford.

“City Engineer” means the Director of Engineering. (Bylaw 1926)

“City of Langford Supplements” are supplements to the Master Municipal Construction Documents (MMCD), latest edition.

“Community Plan” means the Langford “Official Community Plan Bylaw No. 1200, 2008” and as amended.

“Completion” - for the purpose of assessing applications, means a Servicing Agreement has been executed or a pre-construction meeting has been held with City representatives.

“Construction Acceptance” means the City’s acceptance of the construction of Works and Services provided by a Developer pursuant to this Bylaw, subject to the obligation of the Developer to remedy defects and deficiencies becoming apparent during the Warranty Period. (Bylaw No. 1494)

“Contractor” is the person, firm or corporation under contract with the City or developer to provide labour, equipment and materials for the execution of the works.

“Core Area” as defined in Zoning Bylaw 300.

“Cul-de-sac” means a highway of which one end is designed to be permanently closed to motor vehicles, or which is terminated by a natural feature and which provides a vehicular turning area.

“Deep Sewers” means those installed at greater than 3.0 metres below finished grade.

“Developer” means the owner or authorized agent engaged in the process of subdividing or developing the subject property.

“Development” means any improvement to residential, commercial, industrial, institutional or municipal lands, highways and rights-of-way, including the construction, alteration or repair of a building pursuant to a building permit.

“Diameter at Breast Height (DBH)” is measure at 1.3 m from natural grade on the highest side of tree. For DBH of multi-stem trees that stem out below 1.3 m, each stem shall be considered its own tree requiring assessment and replacement.

“Director of Engineering” means the person appointed by the City as the Director of Engineering and Public Works or any employee authorized to act on that person’s behalf. (Bylaw 1926)

“Director of Parks” means the person appointed by the City as the Director of Parks, Recreation and Facilities (also known as the Manager of Parks or Parks Manager) or any employee authorized to act on that person’s behalf. (Bylaw 1926)

“Engineer or Geoscientist of Record” or “Record Engineer” or “Record Geoscientist” means a Professional Engineer or Geoscientist engaged by a Developer to provide certifications required by this Bylaw, a Statement of Conditions, a Development Permit or a Building Permit. (Bylaw 1513)

“Final Acceptance” means the City’s acceptance of Works and Services provided pursuant to this Bylaw at the end of the warranty period with all defects and deficiencies remedied to the satisfaction of the City Engineer. (Bylaw No. 1494)

“Final Approval” means the Approving Officer’s signature on the final plan of subdivision. (Bylaw No. 1669)

“Highway” includes a street, road, lane, bridge, viaduct and any other way open to the use of the public, but does not include a right-of-way on private property, other than an access route in a bare land strata plan that, in the opinion of the City Engineer must be designed to City standards in the interest of public safety and emergency access.

“Landscape Retaining Wall” means a retaining wall that is not a Structural Retaining Wall. (Bylaw 1513)

“Lane” means a Highway which provides a secondary means of vehicle access to one or more Parcels of land. (Bylaw 1513)

“Maintenance Period” means a period of one year starting from the date of Constructional Acceptance – Landscaping (CA-L), unless a greater period is specified in this Bylaw in relation to deficiencies and replacement. During this period, the Developer must maintain all offsite horticultural (i.e. trees, shrubs, sod etc.) and non-horticultural (i.e. irrigation, pavers, benches etc.) elements as approved in design drawings.

“Medical Health Officer” means the Medical Health Officer for the Vancouver Island Health Authority.

“Municipal Sewer System” means the network of pipes and infrastructure placed so as to receive and direct sewage from two or more parcels of land to a treatment facility, which is owned and operated, by municipal government or City.

“Parcel” means any lot, block or other area in which real property is held or into which real property is subdivided, but does not include a highway or portion thereof and includes the remainder of a parcel.

“Potable Water” means water, which is approved for drinking purposes by the Medical Health Officer pursuant to the *Health Act*.

“Professional Engineer” or “Consulting Engineer” means a person who is registered or licensed and in good standing in the Province of British Columbia as such under the provisions of the *Engineers and Geoscientists Act*.

“Professional Geoscientist” means a person who is registered or licensed as such and is in good standing under the provisions of the *Engineers and Geoscientists Act*. (Bylaw 1513)

“Right-of-Way” means land or any interest in land acquired for the purpose of:

- (a) public rights of passage with or without vehicles; or
- (b) erecting and maintaining any pole-line; or
- (c) laying, placing and maintaining drains, ditches, pipes, transmission lines or wires for the conveyance, transmission or transportation of water, electric power, forest products, oil or gas or both oil and gas or solids as defined in the *Pipeline Act*; or
- (d) the transmission or disposal of sanitary sewage, storm water or drainage;
- (e) the operation and maintenance of any other undertaking of the City; and shall include a statutory right-of-way as defined in the *Land Title Act*.

“Road” means the portion of a highway constructed for vehicular traffic.

“Statement of Conditions” means the letter issued by the Approving Officer for the City to a land owner or agent that outlines the legal, servicing and procedural conditions that must be met prior to obtaining subdivision approval.

“Structural Retaining Wall” means a wall that is structurally independent from a building or structure but is required to support the building or structure, or a wall that supports a road. (Bylaw 1513)

“Subdivision” means the division of land into two or more parcels, whether by plan, descriptive words or otherwise, and includes boundary adjustments.

“Subdivision Approval” means approval of the subdivision of land granted by the Approving Officer when all relevant requirements of this bylaw, the *Land Title Act* and any other relevant bylaws and legislation have been fulfilled.

“Substantial Performance” means the stage of construction completion when all Works and Services as certified by the Engineer of Record, are capable of completion or correction and are ready for use or being used for the purpose intended. (Bylaw No. 1669)

Deleted. (Bylaw No. 1494)

“Walkway” means an area of land improved primarily for the use of pedestrian traffic.

"Warranty Period" means a period of one year starting from the date of Substantial Performance, unless a greater period is specified in this Bylaw in relation to particular Works or Services, during which the Developer must remedy any defects in materials or workmanship and other deficiencies that become apparent in the Works and Services. (Bylaw No. 1669)

“Works and Services” means construction such as roadways, lanes, gas, drainage, water and sewer systems, earthworks and slope stabilization, sidewalks, walkways, boulevards, landscaping, street lighting and underground wiring, and includes works and services whether on highways, rights of way or common property, to be provided for in a subdivision or development of land under this bylaw.

“Works and Services Agreement” means an agreement between the City and the owner in accordance with s. 940 of the *Local Government Act* that works and services will be completed to service a subdivision or development by a date specified in the agreement and that sufficient security has been provided to the City to secure the construction of those works,

“Zone” means a zone established by the “Langford Zoning Bylaw, 1999 (No. 300)” and as amended from time to time.

REPEAL

“City of Langford Subdivision Servicing Bylaw No. 500 and all amendments thereto are hereby repealed.

READ a first time this 1st day of February, 2010.

READ a second time this 1st day of February, 2010.

READ a third time this 1st day of February, 2010.

ADOPTED this 15th day of February, 2010.

MAYOR

ADMINISTRATOR

City of Langford

Subdivision and Development Servicing Bylaw No. 1000

List of Amendments to Bylaw No. 1000

	Amendment	Bylaw Number	Date Adopted
1	s.944 Delegation Bylaw – Delegate the Power of Exemption of Minimum Frontage Requirements to the Approving Officer	1321	21 Feb 2011
2	Minor adjustments to improve the usability of the bylaw	1292	7 Mar 2011
3	Redefine the definition of Development	1352	19 Sep 2011
4	Replacing Section 6.1.1 and adding a map as Appendix A as Figure 6.1 within Section 6.1	1361	3 Oct 2011
5	To amend the definition of “Development” and replacing Section 6.1.	1376	19 Nov 2012
6	To delegate the power of exemption of minimum frontage requirements to the Approving Officer	1459	18 Feb 2013
7	Housekeeping issues, sanitary servicing clarification and addition of Schedule 14 for landscaping	1494	20 Jan 2014
8	Add definitions to Section 4.0, Replace Section 1.1.2.3, Replace Section 2.1.1, Replace Section 3.1.3, Replace Section 3.1.5, Remove drawings R13 to R16 from Schedule 4 and add Drawing R18 and R19, Replace Table 4.1, Add a new paragraph to the end of Section 5.1.1, Remove Figure 6.1, Replace the phrase “Strata Title conversion of an existing two-family dwelling” to “a strata subdivision of a two family dwelling, Replace text below Section 6.1.2.1 ii, Delete Section 9, Replace Section 9.3, Delete Section 9.6 and Replace Section 9.7.	1513	28 May 2014
10	Replacing Table 1-1 “Applications and Fees”	1539	20 Oct 2014
11	Amending Section 1.12.1 and replacing Sections 6.4.5 and 9.3	1555	7 Apr 2015
12	Replacing Sections 4.11.4, 4.15.1.3, 4.15.1.5, and Drawing C15	1574	15 Jun 2015
13	Replacing Sections 4.18.1, 4.18.1.5, 4.18.3, 4.18.13.1.5, adding Section 4.18.1.11, amending Schedule 11, and replacing Drawings E3, E4, and E7 in Section 11	1618	4 Apr 2016
14	Replacing Table 1-1 “Applications and Fees” in Schedule 1 Procedures and Fees	1635	16 May 2016
15	Omnibus Amendment.	1669	20 Feb 2017
16	Replacing Table 1-1 “Applications and Fees” in Schedule 1 Procedures and Fees.	1707	8 June 2017
17	Replacing the phrase "six month" in Section 1.5.1 with "twelve month, Replacing the phrase "six month" in Section 1.5.1.3 with "twelve month, adding section 1.5.1.4, inserting section 1.8 Air Space Parcel Subdivision and renumbering subsequent sections accordingly and Replacing Table 1-1 “Applications and Fees” in Schedule 1 Procedures and Fees.	1783	16 July 2018
18	Omnibus Amendment.	1817	1 Apr 2019
19	Replacing Table 1-1 “Applications and Fees”	1849	4 June 2019
20	Replacing Table 1-1 “Applications and Fees”	1901	29 June 2020
21	Withdrawn	1947	N/A
22	Replacing Table 1-1 “Applications and Fees”	1967	19 July 2021
23	Replacing Table 1-1 “Applications and Fees”	2046	20 June 2022
24	Housekeeping Amendments	2103	17 July 2023
25	Housekeeping Amendments and Amendments to Schedules 3 & 4	1926	9 May 2024

27	Replacing Table 1-1 “Applications and Fees”	2120	17 Mar 2025
----	---	------	-------------

**CITY OF LANGFORD
BYLAW NO. 2120**

A BYLAW TO AMEND THE SUBDIVISION AND DEVELOPMENT SERVICING BYLAW

The Council of the City of Langford, in open meeting assembled, enacts as follows:

- A. City of Langford Subdivision and Development Servicing Bylaw No. 1000 is amended as follows:
1. By replacing Table 1 – 1 “Applications and Fees” in Schedule 1 Procedures and Fees with the table attached.
- B. That the fees automatically be adjusted effective May 1 of each year by the annual percentage change in the All Items Consumer Price Index (CPI) for Greater Victoria for the then most recently ended calendar year as published by Statistics Canada or successor in function.
- C. This Bylaw may be cited as “Subdivision and Development Servicing Bylaw, Amendment No. 24, (Fee Schedule), Bylaw No. 2120, 2025”. [Should have been Amendment No. 27, 2025 (Fee schedule)]

READ A FIRST TIME this 3rd day of March, 2025.

READ A SECOND TIME this 3rd day of March, 2025.

READ A THIRD TIME this 3rd day of March, 2025.

ADOPTED this 17th day of March, 2025.



PRESIDING COUNCIL MEMBER

**SCOTT GOODMANSON
MAYOR**



CORPORATE OFFICER

**Melisa Miles
Deputy Corporate Officer**

SCHEDULE 1 PROCEDURES AND FEES

- 1.1. Application for the Approving Officers Statement of Conditions for the Approval of a Subdivision.
 - 1.1.1. Any property owner or other person wishing to subdivide land must obtain a statement from the Approving Officer of the complete conditions which must be fulfilled in order to obtain approval of a subdivision and shall pay an application fee plus an additional fee for each parcel proposed to be created in addition to the number of existing parcels.
 - 1.1.2. The application shall be accompanied by:
 - 1.1.2.1. DELETED (Bylaw No. 1292);
 - 1.1.2.2. Copies of all rights of way, easement and covenant documents pertaining to the subject property;
 - 1.1.2.3. One (1) paper copy and a digital PDF drawing of the proposed subdivision; (Bylaw No. 1669)
 - 1.1.2.4. Legal description;
 - 1.1.2.5. The location and setbacks of all existing structures;
 - 1.1.2.6. The location of protected areas, elements and / or natural areas;
 - 1.1.2.7. All road frontages with existing road names;
 - 1.1.2.8. Size and dimensions of existing and proposed lots;
 - 1.1.2.9. Existing water bodies and water courses;
 - 1.1.2.10. Topographic information at 0.5m contour lines;
 - 1.1.2.11. Registered Covenants pertaining to existing rights of way or easements;
 - 1.1.2.12. A letter of authorization from the owner if an agent is acting on their behalf.
 - 1.1.3. In considering a subdivision (application for Statement of Conditions, or request for Final Approval or at any time during), the Approving Officer may request that additional information be provided by a registered professional in regards to natural and or geotechnical hazards, both on-site and off-site, which may impact the subdivision (as noted in s.86 of the *Land Title Act*). These may include but are not limited to: avalanche, debris torrent, earthquake, erosion, flooding, fire, rock fall, land slippage and unstable soils and tsunami.

1.1.3.1 The registered professional preparing the reports noted in Section 1.1.3 shall provide a statement in that report that the report in question may be relied upon by the City for the purpose of confirming the feasibility of the subdivision.

1.1.4 All reports that relate to the feasibility of any lands within or adjacent to the project are being prepared by the registered professional and to be provided to the City.

1.1.5 The design engineer that is providing their professional seal and signature in regards to the works must ensure that any reports and reviews (including geotechnical work) shall be provided. The work must also be identified on the plans and coordinated with a registered professional of that field. This shall include all private lands, municipal works and lands, and adjacent lands that have been directly or indirectly impacted by the subdivision as necessary.

1.2. Referrals

1.2.1. The City will forward referrals to all relevant City departments and external agencies whose input is required by law or required in the opinion of the Approving Officer regarding the application for subdivision approval. Should the agency require a fee for this referral, the City will provide this information to the applicant. The applicant will be responsible for paying the applicable fees to that agency at that time. The City will not process payments to other agencies.

1.3. Boundary Adjustments

1.3.1. Where the proposed subdivision is a boundary adjustment the appropriate application fee is required in accordance with Table 1.

1.4. Revision to the Layout

1.4.1. If, in the opinion of the Approving Officer, the subdivision layout has changed substantially so that additional referrals and a new Statement of Conditions is necessary, or the Statement of Conditions has expired without application for an extension, the existing file will be closed and a new application and fees will be required.

1.5. Extensions

1.5.1. If the applicant cannot apply for approval of the subdivision within one calendar year from the date of issuance of the Approving Officer's Statement of Conditions, the applicant may request one twelve month extension and pay the extension fee in accordance with Table 1. (Bylaw No. 1783)

1.5.1.1. The applicant may be subject to new bylaw requirements or fees after one year of the initial application even if an extension has been granted.

1.5.1.2. If no request for extension has been made prior to the expiration of the Statement of Conditions, the applicant must apply for a new Statement of Conditions.

- 1.5.1.3. If, in the opinion of the Approving Officer the delay in subdivision approval is due to unreasonable delays on the part of the City, the extension may be granted beyond the twelve month period. (Bylaw No. 1783)
 - 1.5.1.4. Despite subsection 1.5.1, the Approving Officer may consider issuing more than one extension if, in the opinion of the Approving Officer, work has substantially progressed towards completion during the period of the current extension and is reasonably expected to achieve subdivision approval prior to the expiry of the newly requested extension. (Bylaw No. 1783)
- 1.6. Phased Strata
- 1.6.1. Applications for approval of a phased strata plan must be accompanied by a fee in accordance with Table 1.
- 1.7. Bare Land Strata Conversion to Fee Simple Lots
- 1.7.1. For a Bare Land Strata plan that amends the plan to create fee simple lots, the fee to examine the plan shall be in accordance with Table 1, Unit fees for Pre-Design Meeting of a Subdivision.
- 1.8. Air Space Parcel Subdivision. (Bylaw No. 1783)
- 1.8.1. Applications for approval of an Air Space Parcel Subdivision must be accompanied by a fee in accordance with Table 1. (Bylaw No. 1783)
- 1.9. Pre-Design Meeting
- 1.9.1. Any applicant intending to construct works or services required for the approval of a subdivision or development shall arrange for a pre-design meeting and pay, at the request for the meeting, an administration fee and a fee for each parcel to be created in addition to the number of existing parcels.
- 1.10. Works and Services for Subdivision or Development.
- 1.10.1. All construction drawings required for subdivision or land development that require the review of the City Engineer for approval to construct on site works and services, shall be accompanied by a fee in accordance with Table 1 of this Bylaw.
 - 1.10.2. The applicant shall submit one (1) copy of drawings for those Works and Services prepared by a Professional Engineer for approval by the City Engineer. See Schedule 12 for Drafting Requirements. (Bylaw No. 1669)
 - 1.10.3. Concurrent with the submission of construction drawings, any Professional Engineer engaged by the applicant must provide the City with a letter that:

- 1.10.3.1. The Professional Engineer's scope of engagement shall include, but is not limited to, assurance of the completeness of the design, certification and submission of construction drawings, coordination of engineering sub-consultants and Record drawings and certification that the design and construction of all Works and Services substantially meet Bylaw 1000 requirements. (Bylaw No. 1669)
- 1.10.3.2. States the following:
"I _____ a Professional Engineer qualified and eligible to practice in the Province of British Columbia, hereby certify that the following works _____ as set out on the drawings submitted currently with this letter have been designed to good engineering standards and in substantial accordance with the latest edition of Subdivision and Development Servicing Bylaw No. 1000, and the Master Municipal Construction Documents (MMCD – latest edition), adopted by the City of Langford."
(Signature) (Bylaw No. 1669)
- 1.10.3.3. States that the Professional Engineer will advise the City Engineer of any severance of engagement during the course of design and construction.
- 1.10.3.4. Sets out construction cost estimates for the Works and Services, certified by the Record Engineer. (Bylaw No. 1669)
- 1.10.3.5. States that the Professional Engineer will provide Storm Water Management declarations as outlined in Section 5.14.
- 1.10.4. Any construction of works and services required under this Bylaw prior to approval to construct by the City Engineer is at the owner's risk.
- 1.10.5. Boulevard, street tree and irrigation design shall be provided by the professional Engineer or other recognized professional. Any street enhancements within a City right of way or easement shall require design by a recognized professional unless otherwise dictated by the City Parks Manager.
- 1.11. Acceptance of Civil Works and Services by the City. (Bylaw No. 1669)
- 1.11.1. The City will not issue Construction Acceptance of Civil Works and Services that are to be owned and maintained by the City until the Works and Services have been approved and installed, and: (Bylaw No. 1669)
- 1.11.1.1. The Record Engineer has certified Substantial Performance and concurrently identifies all defects and deficiencies in the Works and Services and any outstanding items; and (Bylaw No. 1669)
- 1.11.1.2. An application is made by the Record Engineer to the Director of Engineering to acknowledge Substantial Performance. (Bylaw No. 1669)

- 1.11.2. Upon being satisfied with the application and certifications of the Record Engineer, the Director of Engineering will issue, in writing, an Acknowledgement of Substantial Performance. (Bylaw No. 1669)
- 1.11.3. Upon Acknowledgement of Substantial Performance the City will add the Works and Services to the City's maintenance contract. (Bylaw No. 1669)
- 1.11.4. The developer shall remedy any defects or deficiencies and complete all uncompleted work identified at time of Acknowledgement of Substantial Performance and shall provide to the City, in addition to the security required by Section 1.15.1, security in the amount of 2 times the amount estimated by the Record Engineer as the cost of remedying defects and deficiencies and completing the Works and Services. The return of this security is conditional upon correction of defects and deficiencies and completion of the Works and Services. Security may be in the form of cash or a letter of credit. (Bylaw No. 1669)
- 1.11.5. Any defects or uncompleted work identified at time of Acknowledgement of Substantial Performance shall be completed within 2 months (or other period as agreed with the Director of Engineering), failing which the City may perform the work and recover its cost from the security. Construction Acceptance by the City will not be issued until all deficient matters are addressed to the satisfaction of the Director of Engineering. (Bylaw No. 1669)
- 1.11.6. Geotechnical certification required by Schedule 3 of this bylaw shall be submitted prior to Acknowledgement of Substantial Performance. (Bylaw No. 1669)
- 1.11.7. The developer shall provide to the Director of Engineering within 2 months of Acknowledgement of Substantial Performance: (Bylaw No. 1669)
 - 1.11.7.1. One AutoCAD and one PDF copy of the Record drawings. (Bylaw No. 1669)
 - 1.11.7.2. As-constructed inventory sheet, supplied by the City, to be completed and submitted to the City as a signed and sealed document by a Professional Engineer. (Bylaw No. 1669)
 - 1.11.7.3. Acceptance by the appropriate utility of all utilities installed within road rights of way. (Bylaw No. 1669)
 - 1.11.7.4. Electrical declaration from the provincial safety authority. (Bylaw No. 1669)

1.12. Application for Subdivision Approval

- 1.12.1. Any applicant intending to apply for final approval of a subdivision shall pay the appropriate application fee.
- 1.12.2. If the Approving Officer's signature has expired and the plans require re-approval due to delays beyond the control of the City, a fee must be paid in accordance with Table 1.

1.12.2.1. Final approval of the subdivision will not be granted to the applicant by the Approving Officer unless the City has issued Construction Acceptance, or the applicant has entered into a Works and Services Agreement with the City. Subdivision plans submitted for final subdivision approval must be accompanied by: (Bylaw No. 1494)

- A state of title certificate current within seven days of final approval application;
- All executed legal documentation as required by the Approving Officer, complete with priority agreements if necessary;
- Deleted. (Bylaw No. 1669)
- Approved road names included on the plan (Road names must be approved by the Fire Department and in accordance with City street naming policies);
- One Auto CAD digital copy to NAD83 coordinates, referenced to two monuments;
- One PDF copy of the subdivision plan;

1.11.4 The owner must provide proof that property taxes are up to date prior to final approval.

1.13. Works and Services Agreements

1.13.1. In the event that an owner of land wishes to obtain approval of a subdivision or issuance of a building permit prior to the construction and installation of works and services required by this bylaw, the owner may enter into a servicing agreement with the City. All Works and Services Agreements may be executed by the City of Langford Council. (Bylaw No. 1555)

1.13.2. A Works and Services Agreement will only be considered after approval has been given for Construction of Works.

1.13.3. Any owner intending to enter into a servicing agreement pursuant to this section must provide to the City a letter of credit, or cash equal to 100% of the cost of the works and services required, the estimate of which is to be certified by a Professional Engineer, and must provide a date for the completion of the works and services for the purposes of s.940 of the *Local Government Act*. The security shall be returned to the owner upon Construction Acceptance by the City, less any amount retained as security for the owner's obligations during the Warranty Period. (Bylaw No. 1494)

1.14. Deleted. (Bylaw No. 1669)

1.14.1. Deleted. (Bylaw No. 1669)

1.14.2. Deleted. (Bylaw No. 1669)

1.15. Warranty Period and Security

1.15.1. During the Warranty Period, the developer shall remedy all defects and deficiencies becoming apparent in the Works and Services, and shall provide upon Acknowledgement of Substantial Performance by way of cash or a letter of credit, security in the amount of 10% of the actual cost of the Works and Services as certified by the Record Engineer, to ensure performance of the Developer’s obligations during the Warranty Period, which shall be returned to the Developer upon Final Acceptance. (Bylaw No. 1669)

1.15.2. The actual cost of the Works and Services for the purposes of Section 1.15.1 shall be certified by a Professional Engineer and approved by the City. (Bylaw No. 1494)

1.15.3. The City may draw upon the Warranty Bond in whole or in part at any time prior to the expiration of the one year warranty period for repairs pertaining to the installation of the works and services, if the developer fails to do so within a reasonable time period as stipulated by the City Engineer.

1.15.4. Should a deficiency be noted at any time during the one-year warranty period, the warranty provider will be notified and given 30 days to repair the deficiency to City standards. After acceptance of the repair, the City may elect to extend the warranty period for the repaired item for up to one year.

1.15.5. The one year warranty bond shall be returned at final acceptance.

Table 1 – 1: Applications and Fees

Section	Application Type	Fee	Unit Fee
1.1.1	Application for the Approving Officer’s Statement of Conditions (Residential Lots)	\$580	Plus, \$200 per new lot created
1.1.1	Application for the Approving Officer’s Statement of Conditions (Commercial or Industrial)	\$690	Plus, \$500 per new lot created
1.3.1	Boundary Adjustment	\$970	Plus \$250 per each additional lot line to be adjusted
1.4.1	Application for a revised Statement of Conditions (when applied for within one year of original application), which may include an extension	\$970	Plus, \$200 per amendment
1.5.1	Extension of a Statement of Conditions	\$340	12-month extension
1.5.1	Signature Expiration (or re-signature)	\$130	
1.6	Approval of a Phased Strata Plan; or amendment of Phased Strata Plan (due upon Form P submission)	\$970	Plus, \$500 per phase
1.7.1	Strata-Title Conversion Residential Compliant	\$970	
1.7.1	Strata-Title Conversion Residential Non-Compliant	\$2,620	
1.7.1	Strata-Title Conversion Commercial/Multi Family/ Industrial Compliant	\$1,900	
1.7.1	Strata-Title Conversion Commercial/Multi Family/ Industrial Non-Compliant	\$3,810	

1.8.1	Air Space Parcel	\$690	Plus, per new lot created: <ul style="list-style-type: none"> • \$400 Residential and other non commercial or industrial uses • \$500 Commercial, Industrial Plus \$5,000 for legal review, the unused portion of which shall be refunded
	Road Closure and Disposition or Encroachment Agreement	\$2600	For Council to consider an application where a road closure and disposition or encroachment are requested (plus the cost of required advertisements and surveying)
1.9.1	Application for Pre-Design Meeting	\$970	Plus, per new lot created: <ul style="list-style-type: none"> ➢ \$200 for <500m² lots (one- or two-family residential) ➢ \$300 for >500m² and <835m² lots (one- or two-family residential) ➢ \$500 all other residential ➢ \$500 Commercial or Industrial
1.10.1	Application to Construct – On Site (Construction Administration Fee)	\$970	Plus 2.5% of engineers estimate of cost of works and services up to \$200 000 and 1% of the remainder
	Application to Construct – Off Site (in existing road ROW) (Construction Administration Fee)		In accordance with Highway Use Bylaw (Bylaw No. 33) To include all utilities except Hydro
1.12.2	Application for Final Approval of a Subdivision	\$900	Plus, per new lot created: <ul style="list-style-type: none"> ➢ \$150 for <500m² lots (one- or two-family residential) ➢ \$200 for >500m² and <835m² lots ➢ \$500 all other residential ➢ \$500 Commercial or Industrial ➢ DCC Payment Due (Residential ONLY)
	Integrated Survey Area Program Plan	\$55	\$50 per lot created by subdivision or strata

SCHEDULE 2 GENERAL REQUIREMENTS

2.1 Servicing of Lands

- 2.1.1 Every owner of land proposed for subdivision or development shall provide, locate and construct at their own expense; Canada Post community mailboxes, highways, sidewalks, boulevards, street trees, irrigation systems, plant material, lawn, transit bays, street lighting, water distribution systems, fire hydrant systems, sewage collection systems and drainage disposal systems on the lands or highways immediately adjacent to the lands being subdivided or developed as required by this bylaw, in accordance with the City of Langford Supplements and the Master Municipal Construction Documents (MMCD) latest edition, in that order. (Bylaw 1513)

2.2. Service Locations

- 2.2.1. All services shall be provided underground and within the municipal road right of way unless otherwise exempted by this Bylaw.
- 2.2.2. No statutory rights of way on private property for City or private utility services are permitted without the approval of the City Engineer. Any permitted rights of way shall have the City of Langford named as a third party.
- 2.2.3. Rights of way for storm or sanitary services, where permitted, shall have a width equal to twice the depth of the service, unless certified for trench stability and construction safety by the geotechnical engineer of record or a different width is approved or required by the Director of Engineering. Rights of way shall be unobstructed and be reasonably accessible for maintenance as approved by the Director of Engineering. (Bylaw No. 1669)
- 2.2.4. If the storm drain and sanitary sewer are located in the same trench, the right of way width shall be measured from the centre line of each pipe.
- 2.2.5. Applications for approval of proposed construction crossing a high-pressure gas distribution main, trunk water main or railway must be made by the Professional Engineer with the consent of the City Engineer to the proper authorities.

2.3. Community Mailboxes

- 2.3.1. Community Mailbox location and accessible access shall be shown on the construction drawings and must adhere to Canada Post current standards. Canada Post shall review and approve all new community mailbox locations.

2.4. Transit Services

- 2.4.1. Where applicable, publicly accessible transit stops shall be designed and installed in accordance with the requirements of the service provider.

2.5. Mitigation Planning

- 2.5.1. The City Engineer requires that the owner of lands, for which an application to subdivide or develop will or has been submitted, shall prepare and submit to the City for approval, to the satisfaction of the City Engineer prior to any demolition or land alteration, a mitigation plan at the owner's expense in accordance with sections 2.5.2 through 2.5.6, as they may apply to the lands. The mitigation plan is required where there are reasonable grounds to anticipate any discharge of contaminants, pollutants, silts, airborne particulates (dust) or materials (toxic or natural) to any watercourses, municipal ditches and sewage systems, public or private lands, waters or the atmosphere.
- 2.5.2. The plan shall include a statement of the expected nature, amount and concentration of contaminants, pollutants silts, airborne particulates (dust) and materials (toxic or natural) from the land which are expected to be discharged to adjoining lands, water, watercourses, utility systems or the atmosphere during the course of subdivision, construction and development of the land to construction completion.
- 2.5.3. The mitigation plan shall state the pertinent environmental or health and safety standards that will govern the proposed discharge of contaminants, pollutants silts, airborne particulates (dust) or materials (toxic or natural) to the air, soil or water during the course of subdivision, construction and development of the land.
- 2.5.4. The mitigation plan which requires works and services or facilities to control pollution or discharge during subdivision and development of the lands will include detailed plans and specifications of the works and services or facilities sealed by a Professional Engineer. Where a mitigation plan requires these works and services or facilities, the owner of the lands or their designated representative shall submit a letter of supervision that is an undertaking to inspect the construction, operation and decommissioning of the pollution control works and services and facilities.
- 2.5.5. Where applicable, the mitigation plan shall be referred to the Ministry authority having jurisdiction including Provincial and Regional agencies, where a discharge is anticipated to a municipal utility system or to the atmosphere.
- 2.5.6. Every person shall implement the mitigative measures at the owner's expense in accordance with the approved mitigation plan for the lands and adhere to the approved mitigation plan submitted to the City when:
 - 2.5.6.1. Carrying out construction, excavation, repair, demolition, or any other activity ancillary thereto; or
 - 2.5.6.2. Depositing, moving or removing any soil.
- 2.5.7. The City may issue a notice in writing to a person not in compliance with Section 2.5.6 of the Bylaw requiring the person to comply with Section 2.5.6.

- 2.5.8. If a person fails within 24 hours to comply with a notice issued under Section 2.5.7 of this Bylaw, the City by its employees or authorized contractors may implement the mitigative measures in accordance with the approved mitigation plan submitted to the City for the lands.
- 2.5.9. If the City takes action pursuant to Section 2.5.8 of this Bylaw, the City may recover its costs as a debt from the owner of the parcel on which the activities listed in Section 2.5.6 are being carried out. An amount due to the City under this section may be collected in the same manner and with the same remedies as property taxes, and if due and payable on December 31 and unpaid on that date is deemed to be taxes in arrears.
- 2.5.10. Any person who contravenes Section 2.5 of this Bylaw commits an offence and upon summary conviction shall be liable to a fine not exceeding \$10,000.00.
- 2.5.11. Each day that a contravention of Section 2.5 of this Bylaw continues shall constitute a separate offence.
- 2.5.12. This Bylaw may be enforced by means of a ticket in accordance with the Community Charter, SBC 2003 c 26 and in the form prescribed in the Community Charter Bylaw Enforcement Ticket Regulation.
- 2.5.13. Employees of the City appointed by Council for the enforcement of city bylaws or members of the RCMP are designated as Bylaw Enforcement Officers for the purpose of enforcing this Bylaw.
- 2.5.14. The words or expression shown in Column 1 of Schedule "15" which forms part of this Bylaw designate the offence committed under the Bylaw section number appearing in Column 2 opposite the words or expression.
- 2.5.15. The dollar amounts shown in Column 3 of Schedule "15" establish the fines for the corresponding offences shown in Column 1.
- 2.6 During construction of the subdivision or development, the developer must ensure that all streets adjacent to the subdivision or development are cleaned every Friday before 3:00 p.m. for the duration of works on site, and as required by the City Engineer. If the developer fails to do so, the City may arrange for the street cleaning at the cost of the developer, which cost shall be payable to the City immediately upon the presentation of the City's invoice to the developer.

SCHEDULE 3 EARTHWORKS

3.1 Geotechnical General

- 3.1.1. A geotechnical plan showing the intent and scope of all geotechnical works on and off site is required and must be certified by a Professional Engineer and submitted with the construction drawings for approval.
- 3.1.1.1 The Professional Engineer must apprise the City Engineer of any changes, alterations or unforeseen circumstances relating to the geotechnical works.
 - 3.1.1.2 Inspection reports for all geotechnical works and findings relating to on and off site works for the subdivision or development are to be copied to the City Engineer.
 - 3.1.1.3 Certification by the Professional Engineer or Geoscientist of Record that the land is safe for the intended use is required upon construction completion in accordance with Section 56 of the *Community Charter* and shall be provided to the owner and the City prior to subdivision or building permit whichever comes first. (Bylaw 1926)
 - 3.1.1.4 Every retaining wall shall be designed and constructed in accordance with the most recent version of the Engineers and Geoscientists BC's Professional Practice Guidelines *Retaining Wall Design* with the completed assurance statement provided upon construction completion to the owner and the City. (Bylaw 1926)
 - 3.1.1.5 Every cut or fill slope shall be designed and constructed in accordance with the most recent version of the Engineers and Geoscientists BC's Professional Practice Guidelines *Landslide Assessments in British Columbia* with the completed assurance statement provided upon construction completion to the owner and the City. (Bylaw 1926)
 - 3.1.1.6 For every retaining wall over 3.0 meters in height and for every retaining wall deemed as high risk by the Professional Engineer or Geoscientist of Record, the owner shall complete a comprehensive design review, prepared by an independent Professional Engineer or Geoscientist, and provide that authenticated independent review to the City with the geotechnical plan and drawings for approval. (Bylaw 1926)
 - 3.1.1.7 Every cut or fill slope must be designed to not cause physical harm to a person or personal property. Permanent rock faces must either have an exclusion zone or catchment ditch that has adequate signage to warn any person of the hazard and that is permanently fenced off. If another method of face stabilization is employed as recommended by the Professional Engineer or Geoscientist of Record, it must be designed and constructed, to the satisfaction of the Director of Engineering, to adequately mitigate risk to persons and property. (Bylaw 1926)

- 3.1.2. The Professional engineer shall provide a digital photographic record of all complete and certified works. This shall include a photograph of each prepared building site, retaining walls and slopes. The elevation of walls or slopes shall be indicated by a levelling rod.
- 3.1.3 For retaining walls greater than 1.2 meters above finished grade:
- 3.1.3.1 Structural Retaining Walls must be certified by a registered Professional Engineer to meet the B.C. Building Code earthquake design standard.
 - 3.1.3.2 Landscape Retaining Walls must be certified by a registered Professional Engineer to be capable of withstanding a 1:475 earthquake event (10% probability of occurring once every 50 years). (Bylaw 1513)
 - 3.1.3.3 The toe of every retaining wall must be set back at minimum 2.0 meters at a maximum slope of 1:4 (rise/run) at any given point from any hard surface for public passage including but not limited to asphalt, concrete, or pavers on highways or walkways, and must include at minimum one separated terrace at an exposed height of 1.0 meter \pm 0.2 meters above finished grade with a minimum distance of 1.2 meters between retaining wall structures at a maximum slope of 1:4 (rise/run) to allow for landscape boulevard with trees in front of the terrace, shrubbery on the terrace, and irrigation throughout, all as approved by and to the satisfaction of the Director of Engineering and Director of Parks. (Bylaw 1926)
- 3.1.4. Retaining walls similar to stacked rock or boulder stack (non-face mortar), smooth concrete block, smooth cast-in-place concrete, shotcrete, or gabion basket type, or cut or fill slopes requiring visible anchoring, meshing, fencing, or other mechanical stabilization measures within the next 10 years, are not permitted unless:
- (a) the works are part of a comprehensive landscape design approved by the Director of Parks; or
 - (b) the works are not visible from any other private or public property, highway or walkway with exceptions for existing physical limitations, as approved by and to the satisfaction of the Director of Engineering. (Bylaw 1926)
- 3.1.5. All retaining walls, and cut or fill slopes, within or reasonably adjacent (within the collapse zone if a failure were to occur) to public property and property that by subdivision or other grant shall become public property, highway or walkway including but not limited to roads, rights-of-way, or dedicated park must be approved by and to the satisfaction of the Director of Engineering and Director of Parks on a case-by-case basis with regard to the effect on surrounding uses, public safety, maintenance, heat reflection, and visual impact. (Bylaw 1926)
- 3.1.6. Masonry walls may not be constructed on top of non-mortared stacked boulder walls without express written permission from the City Engineer and certification from the Professional Engineer of record.

- 3.1.7. All slopes greater than 30% created by the construction of the development or subdivision are to be shown on the as-constructed drawings and certified stable by a registered Professional Engineer, for the B.C. Building Code earthquake design.
- 3.1.8. Areas of fill must be recorded on the engineer's as-constructed drawings and certified by a Professional Engineer as to load carrying capability and long term stability for intended use.
- 3.1.9. The as-constructed drawings shall show any retaining structures including geo grid ties backs, anchors and other Mechanically Stabilized Earth (MSE) devices as certified by the geotechnical engineer, all relative to the property lines. The digital as-constructed drawings shall be to UTM coordinates.
- 3.1.10. Any retaining wall, cut or fill slope greater than 45 degrees from the horizontal and greater than 1.2m in height finished grade to finished grade, must be fenced with 1.2m high black chain link at the top of the wall of slope. Alternative fence types may be approved by the Director of Engineering, with s.219 covenants in place to ensure maintenance over time. (Bylaw No. 1669)
- 3.1.11. All retaining walls visible from public property, highways or walkways must be complementary or consistent with other approved retaining walls in the visible vicinity with regard to type, colour, and pattern, as approved by and to the satisfaction of the Director of Engineering and Director of Parks. (Bylaw 1926)
- 3.1.12. Trees or other proposed vegetation shall not impact the performance of adjacent retaining walls or other structures or infrastructure and shall be installed and maintained as recommended by a Landscape Architect registered and in good standing as a member of the British Columbia Society of Landscape Architects, as approved by and to the satisfaction of the Director of Engineering and Director of Parks. (Bylaw 1926)

3.2. Blasting Requirements

- 3.2.1. Notification and monitoring for any blasting required for the construction of a building, subdivision, development, utility installation and/or road works are required in accordance with this section. These requirements apply where the volume of rock to be blasted for the entire site exceeds 500m³ (in situ), except that no blasting shall be done within 300 metres of a School or Hospital, until notice as required in this bylaw has also been given to the Senior Administrator of the School or Hospital by the owner or contractor and has provided notice to the City Engineer. Further notice must be given to the Senior Administrator, or their designate, at least two hours prior to each actual blast, stating the approximate time of the blast.
- 3.2.2. Where blasting is required for site development and servicing, the blasting contractor shall indicate the estimated location and approximate quantity of the proposed blasting program and shall include a blasting schedule.
- 3.2.3. A certificate of insurance providing a minimum of \$5,000,000 general liability coverage for the Blaster, the Owner and the City of Langford against liability for loss or damage to

persons or property as a result of blasting must be submitted to the City Engineer prior to the commencement of any blasting on site.

- 3.2.4. Where the volume of rock to be blasted for the entire site exceeds 500m³ (in situ), the City Engineer and owners and occupiers within 300 metres of the perimeter of the blast site shall be given 48 hours notice in writing of the commencement of any blasting by the Blaster and at least seven (7) days notice shall be given of any blasting expected to continue for more than one calendar week. The area of proposed notification shall be submitted to the City Engineer and may be modified at the discretion of the City Engineer on the basis of the likely impact of blasting, and all notification of owners and occupiers required under this bylaw shall be given in the area as approved by the City Engineer, with a copy of the notification provided to the City for public display.
- 3.2.5. The notice shall describe the work to be done, the expected date of commencement, duration of the project, methods to be used to safeguard life and property and warning methods used to signal an impending blast and the name and phone number of the representative of the Blaster or Owner who will provide additional information.
- 3.2.6. Blasting shall be exempt from all provisions of this section if the blasting is specifically authorized by a statute or regulation other than the *Local Government Act*, or if the blasting is, in the opinion of the City Engineer, required on an urgent basis to lessen or eliminate an imminent threat to life, safety, property or public transportation routes and communication systems.
- 3.2.7. Deleted. (Bylaw No. 1669)
- 3.2.8. Any person who contravenes Section 3.2 of this Bylaw commits an offence and upon summary conviction shall be liable to a fine not exceeding \$10,000.00.
- 3.2.9. Blasting for the purposes of Development is not allowed on any subdivision or single property after 18 months following the first blast on the site or lot per owner
- 3.2.10. The City may issue a notice in writing to a person not in compliance with Section 3.2 of the Bylaw requiring the person to comply with Section 3.2.
- 3.2.11. If a person fails within 24 hours to comply with a notice issued under Section 3.2.10 of this Bylaw, the City by its employees or designated authority may notify the blasting regulator of British Columbia (WorkSafeBC) of the non-compliance.
- 3.2.12. If the City takes action pursuant to Section 3.2 of this Bylaw, the City may recover its costs including but not limited to reparations as a debt from the owner of the parcel on which blasting is being carried out without the required notifications or insurance being provided. An amount due to the City under this section may be collected in the same manner and with the same remedies as property taxes, and if due and payable on December 31 and unpaid on that date is deemed to be taxes in arrears.
- 3.2.13. Each day that a contravention of Section 3.2 of this Bylaw continues shall constitute a separate offence.

- 3.2.14. This Bylaw may be enforced by means of a ticket in accordance with the Community Charter, SBC 2003 c 26 and in the form prescribed in the Community Charter Bylaw Enforcement Ticket Regulation.
- 3.2.15. Employees of the City appointed by Council for the enforcement of city bylaws or members of the RCMP are designated as Bylaw Enforcement Officers for the purpose of enforcing this Bylaw.
- 3.2.16. The words or expression shown in Column 1 of Schedule "15" which forms part of this Bylaw designate the offence committed under the Bylaw section number appearing in Column 2 opposite the words or expression.
- 3.2.17. The dollar amounts shown in Column 3 of Schedule "15" establish the fines for the corresponding offences shown in Column 1.

SCHEDULE 4 ROAD DESIGN AND CONSTRUCTION

4.1. Classification and Width

- 4.1.1. The City Engineer shall determine the classification of the highways to be constructed or improved. The width of right-of-way and the design speed for horizontal elements shall be determined from the highest future classification of the highway which, in the opinion of the City Engineer, will result from the subdivision or development proposed and in accordance with the Official Community Plan. Reference shall be made to the City of Langford Street Atlas for road classifications and attached road cross sections in this bylaw.

4.2. Vertical Curves

- 4.2.1. Vertical curve criteria shall be in accordance with the Transportation Association of Canada (TAC) standards for the appropriate level of service.

4.3. Road Grades and Crown

- 4.3.1. Road grades and crown are to be in accordance with Table 4-1 and Figure 4-1 of this Bylaw and the following criteria:
 - 4.3.1.1. Minimum grade of roads shall be 0.5% measured at the gutter line. Maximum grade of roads shall be 12% measured at the gutter line.
 - 4.3.1.2. Maximum grade in any direction on the turnaround of cul-de-sac shall be 6.0%
 - 4.3.1.3. Maximum grade of local road or cul-de-sac approach to a collector shall be 5% for a 15 m length measured from the edge of the collector right-of-way
 - 4.3.1.4. Maximum grade of local road, cul-de-sac or collector approach to an arterial shall be 3% for a 15 m length measured from the arterial right-of-way edge
 - 4.3.1.5. Normal crown shall be 2%.
 - 4.3.1.6. Intersections with Ministry of Transportation and Infrastructure roads shall be to Ministry of Transportation and Infrastructure standards.
 - 4.3.1.7. Deleted. (Bylaw No. 1669)
 - 4.3.1.8. A design speed of 30 km/h is permitted for local roads and cul-de-sacs subject to approval by the Director of Engineering. Cautionary speed signs must be posted on all roads with a design speed 30 km/h. (Bylaw No. 1669)

4.4. Super-elevation

- 4.4.1. Horizontal curves on local roads and cul-de-sacs shall not be super-elevated unless approved by the City Engineer. Collector and Arterial roads with a design speed of 60 km/h or greater and with no direct access to the road from the adjacent development, may be super-elevated in accordance with the Transportation Association of Canada (TAC), current edition.

Table 4-1 ROAD CLASSIFICATIONS – ROAD CLASSIFICATION AND DESIGN TABLE

ELEMENT	COLLECTOR								LOCAL						ARTERIAL
	URBAN							INDUSTRIAL	URBAN		RESIDENTIAL LOTS		RURAL		
SECTION	R1	R2	R3	R4	R5	R6	R7	R8	R9	R10	R11	R12	R18	R17	
VPD	7,000 TO 14,000							1,000+	0 TO 2,999		0 TO 500		0 TO 500	0 TO 500	
LANES	2		3			4	5	3	2		2		2	2	
LANE WIDTH	3.2	3.2	3.2	3.2	3.2	3.2	3.4	4.3/4.0*	4.25**	3.0	4.25**	3.0	4.25	3.7	
COMBINED BIKE LANE (OPTIONAL)	4.3 M WIDE CURB LANES***							YES	NO	NO	NO	NO	NO	NO	
BIKE LANES	1.5	1.5	1.5	1.5	1.5	1.5	1.5	1.5	NO	NO	NO	NO	NO	NO	
PARKING	2.6 (1)	2.6 (1)	2.6	2.6 (1)	2.6 (1)	2.6	NO	NO	NO	**	2.6 (1)	**	NO	**	
STREET LIGHTS	YES	YES	YES	YES	YES	YES	YES	YES	YES	YES	YES	YES	YES	YES	
SIDEWALK	2.2 (1)	2.5	2.2	2.2 (1)	2.2	2.2	2.2	2.2	1.8	1.8 (1)	1.8 (1)	1.8 (1)	1.65 (1)	1.8 (1) GRAV.	
MAX. BOULEVARD	1.8/3.7	1.5 o/s	1.7	1.7/3.6	1.7	1.6	2.6	2.5	1.9/3.7	2.75/4.75	2.75/4.75	1.7/2.8	2.55/4.5	1.65/2.2	
R.O.W. WIDTH	20.0	20.0	23.0	23.0	23.0	26.0	26.0	30.0	20.0	18.0	18.0	15.0	15.0	14.0	

* 4.3 METRE WIDE CURB LANES, 4.0 METRE WIDE CENTRE LANES. BIKE LANE INCLUDED IN CURB LANE WIDTH

** PARKING INCLUDED IN LANE WIDTH

*** CAN BE USED IN LIEU OF DEDICATED BIKE LANES

**** MAY BE ELIMINATED IF NO DESTINATION EXISTS BEYOND THE END OF THE CUL-DE-SAC

(1) INDICATES ONE SIDE OF R.O.W. ONLY

o/s ROAD IS OFFSET WITHIN THE R.O.W. TO ACHIEVE EQUAL BOULEVARD WIDTHS OR WIDER BOULEVARD ON ONE SIDE ONLY.



City of Langford Local Roads

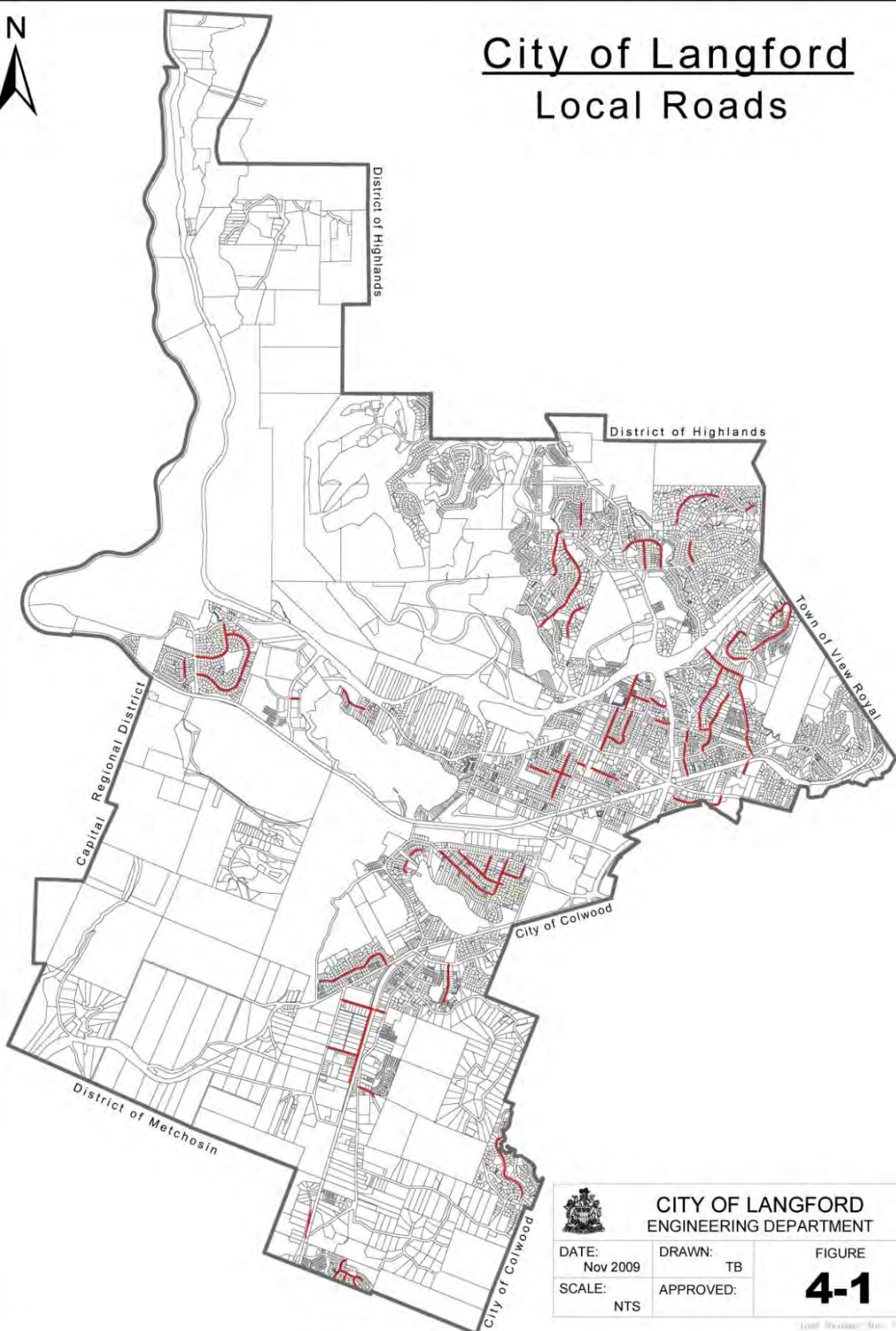

		
CITY OF LANGFORD		
ENGINEERING DEPARTMENT		
DATE: Nov 2009	DRAWN: TB	FIGURE
SCALE: NTS	APPROVED:	4-1

4.5. Horizontal Alignment

- 4.5.1. Where possible, the horizontal alignment of the road shall be centred in the highway right-of-way. This may be varied by the City Engineer to suit local conditions.
- 4.5.2. The minimum centreline radius of curve shall be in accordance with the Transportation Association of Canada (TAC) standards, current edition based on design speed.
- 4.5.3. Where, in the opinion of the City Engineer, a local road or cul-de-sac, has been designed to ensure consistently low driving speeds, the minimum centre line radius may be reduced to suit the minimum service vehicle.
- 4.5.4. All horizontal curve design must be suitable for the use and design speed.

4.6. Cut and Fill Slopes

- 4.6.1. Cut and fill slopes, including ditch slopes, within four metres of the road edge shall be a maximum grade of 6 horizontal to 1 vertical. These slopes shall be planted with grass or trees and shall be made stable under all conditions up to the predicted 1 in 200-year weather or earth movement events. The Director of Engineering may approve alternate cut and fill slopes on a case by case basis and as certified by the Geotechnical Engineer of Record. (Bylaw No. 1669)
- 4.6.2. Slopes greater than 4 horizontal to 1 vertical, the stability of which, in the opinion of the City Engineer, directly affect the safety or stability of the highway, must be completely within the road right-of-way or subject to a Covenant under s.219 of *Land Title Act* or a Statutory Right-of-Way agreement which, in the opinion of the City Engineer, provide reasonable guarantees for the safety and stability of the highway.
- 4.6.3. Hand rails or traffic barriers are required for public safety unless otherwise dictated by the City Engineer.

4.7. Cross Sections

- 4.7.1. Cross Sections shall be in accordance with Table 4-1 and the reference drawings that accompany this schedule.

4.8. Structural Design of Road

- 4.8.1. The minimum compacted gravel base and asphalt requirements shall be in accordance with this Bylaw.
- 4.8.2. A Typical Road Structure shall be in accordance with the reference drawing (Typical Road Pavement Structure – TYP) that accompanies this schedule.

4.9. Stripping of Road Bed

- 4.9.1. All topsoil and organic material shall be removed from the roadways and walkways prior to placement of fills on or cuts of the subgrade as directed by the Professional Engineer.

4.10. Curb and Gutter

- 4.10.1. Where the longitudinal road grade is less than 3%, invert gutters shall be continuous through the parking space and barrier curbs are permitted for the parking space.
- 4.10.2. Curbs shall be non-mountable on all roads except cul-de-sacs, roads within intensive residential development and local roads.
- 4.10.3. Curbs shall be continuous through private road (up to three lanes in width) or driveway intersections with a public highway. The curb shall be continuous with either a curb drop or invert gutter.
- 4.10.4. If the storm water management plan for the subdivision or development requires bioswales parallel to the road, flat concrete curbs are permitted.
- 4.10.5. Backfill material behind curbs and islands shall consist of growing medium to meet the current edition of BC Landscaping Design Standards based on road classification.

4.11. Parking

- 4.11.1. A parking plan is to be provided concurrent with the drawings submitted for construction review and approval. The City Engineer may require additional parking and no parking signage based on the width of proposed roadway.
- 4.11.2. Curb-side parking shall be allowed for against one (1) road edge where the road's paved width is equal to or greater than 8.5m. "No Parking" signage shall be installed on the non-parking road edge as per MUTCD guidelines.
- 4.11.3. No road-edge parking shall be allowed where the road's paved width is less than 8.5m unless provided for in dedicated parking stalls or scallops. "Parking in Designated Areas Only" signage (or signage as allowed for by MUTCD) shall be installed in conjunction with the parking scallops.
- 4.11.4. One on-street parking stall shall be provided for every two lots in a residential development. (Bylaw No. 1574)

4.12. Temporary Turning Areas

- 4.12.1. Where a local road terminates and there is future access to lands beyond; a turnaround shall be provided to the satisfaction of the Fire Chief and may be provided on private property if protected by a right-of-way and covenant registered in favour of the City. The turnaround shall be signed as a 'fire access' with no parking allowed. The right-of-way and covenant shall be discharged when the road connection is complete.

4.13. Sidewalks and Walkways

- 4.13.1. Sidewalks shall be brick pavers in areas designated on Figure 4-4, attached. All other areas shall be concrete sidewalks.

- 4.13.2. Concrete sidewalks shall be 150mm thick at driveway crossings and where mountable curbs are specified, 100mm thick where non-mountable curbs are specified, and shall be 200mm thick at industrial and large format (greater than 10,000 sq m building area) commercial driveway crossings. (Bylaw No. 1669)
- 4.13.3. Brick paver sidewalks shall be 60mm thick where non-mountable curbs are specified and 80mm thick at driveway crossings, crosswalks and parking bays.
- 4.13.4. Sidewalks shall be continuous grade and not drop through the driveways.
- 4.13.5. Sidewalks shall be located in accordance with the appropriate road cross section classification.
- 4.13.6. The crossfall of the sidewalk shall be no less than 2% and no more than 5% towards the road. The back, of sidewalk can be dropped such that the maximum crossfall does not exceed 5%. (Bylaw Nos. 1669, 1817)
- 4.13.7. Where non-mountable curbs are required, ramps shall be provided at all intersections.
- 4.13.8. One Tactile warning strips in accordance with CSA B651-12 must be provided on each side of all driveway drops and on all driveways serving commercial, industrial and multi-family residential developments. Tactile warning strips shall be exposed aggregate for brick sidewalks and shall be a two brick wide stamped pattern if the sidewalk is concrete, adjacent to driveways, drops in grade and crosswalks. (Bylaw No. 1669)
- 4.13.9. In addition to the sidewalk requirements for each classification of road, the sidewalk width shall increase by 25% for sidewalks fronting schools, playgrounds, shopping centres, bus stops, trail systems, beaches and other community facilities, and for proper circulation of pedestrian traffic.
- 4.13.10. Sidewalks are to meander where possible to avoid existing trees and natural features where deemed appropriate by the City Engineer.
- 4.13.11. Service boxes shall be located in boulevards where possible. Where inadequate boulevard exists or there are utility conflicts, services boxes may be located in sidewalk if utility lids are non-slip. Where grades exceed 4% the Director of Engineering may approve utility lids within the sidewalk on a case by case basis as part of the comprehensive design. Service boxes may be located within drive ways in accordance with the specifications of the individual utility provider. (Bylaw No. 1669)
- 4.13.12. If a manhole is permitted in a brick paver sidewalk, a 150mm thick x 150mm minimum wide square apron shall be provided around the manhole castings.

- 4.13.13. Sidewalks are not required for cul-de-sacs that service 10 lots or less unless a sidewalk is required to access an existing or future trail, walking connection, park, school, or adjacent development.
- 4.13.14. Sidewalks adjacent to cul-de-sacs shall terminate at the curb return at the bulb, unless sidewalks are required to provide access to amenities in or beyond the bulb.

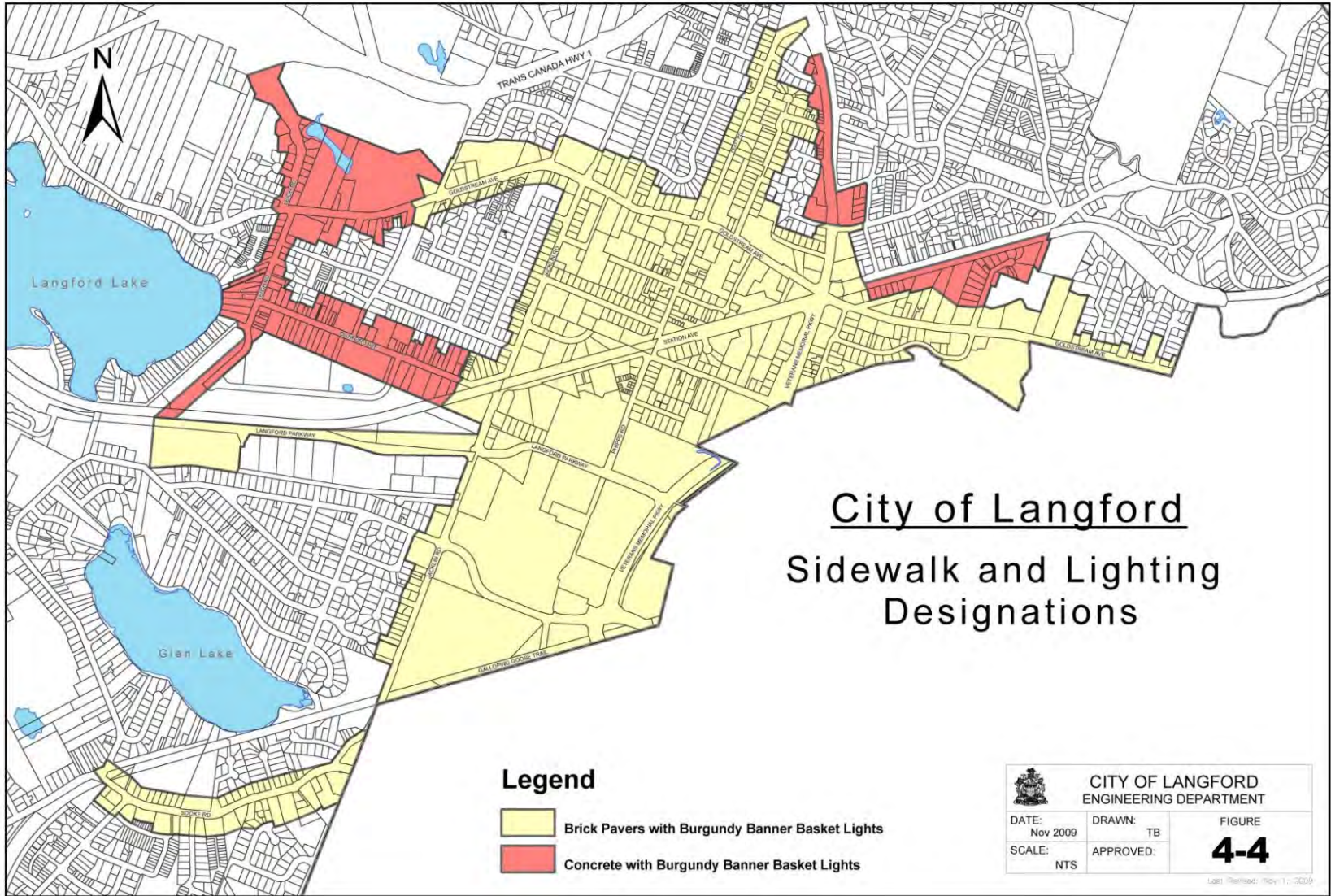

4.14. Street Signage

- 4.14.1. New or replacement street signage within the development and at interfaces with existing roads shall be provided by the developer.
- 4.14.2. Proposed street sign locations are to be identified on the construction drawings.
- 4.14.3. Name blades are to be mounted on approved post-top cast aluminum brackets. See Table 4-2.
- 4.14.4. All Regulatory and Warning signs (as classified in MUTCD) are to be High Intensity Grade Encapsulated Lens Retro reflective material. All other signage may be Engineer Grade.
- 4.14.5. All new or replacement signs are to be in accordance with the standards and specifications of the Manual of Uniform Traffic Control Devices. (Bylaw No. 1669)
- 4.14.6. All materials will meet the CGSB Specifications as to quality and colour in accordance with Section 308 of the General Specifications for Highway Construction.
- 4.14.7. Delineator reflective sheeting will be a minimum of 100 mm wide by 200 mm long and will be in accordance with CGSB Specification 62-GP-11M.
- 4.14.8. Sign posts will be telspar or approved equal with 1.75" x 15" long telspar break offs secured with 3/8" hex bolts or "J" bolts.
- 4.14.9. Sign bases shall be 16" high, have a 10" square bottom, a 8" square top and shall have a 2" telspar inset strengthened with 2-1/4" telspar. The top of the base shall be flush with the finished grade.
- 4.14.10. Sign posts in the core area as identified in the Official Community Plan shall have galvanized sleeves for the full height of the post from concrete post base to the underside of the sign to post fastening assembly.
- 4.14.11. All necessary hardware for installation of signs, such as lag screws and washers, will be of non-corrosive material to avoid discoloration of sign and delineator faces.
- 4.14.12. Backfill shall be native material and be properly compacted in layers.
- 4.14.13. New installations and replacement of street name blades are to be installed according to the following table (4-2):

Table 4-2: Street Name Blade Placement Requirements

Location	Type	Colours	Size
All intersections in the Core area	Two sided extruded aluminum	100mm 'Helvetica Medium, uppercase black IP vinyl lettering on white EG reflective background, c/w full-colour coat of arms	150mm x 400mm – 800mm
All Collector Roads	Two sided extruded aluminum	100mm 'Helvetica Medium, uppercase black IP vinyl lettering on white EG reflective background, c/w full-colour coat of arms and detailing	230mm x 400mm – 800mm
Private	Two sided extruded aluminum	100mm 'Helvetica Medium', uppercase white EG reflective lettering on blue EG reflective background	150mm x 400mm – 800mm
Other	Two sided extruded aluminum	100mm 'Helvetica Medium, uppercase black IP vinyl lettering on white EG reflective background c/w black IP vinyl coat of arms	150mm x 400mm – 800mm

4.15. Driveways

4.15.1. Any driveway unable to meet the following criteria must obtain written approval from the City Engineer.

4.15.1.1. The minimum driveway width shall be 4.5 metres pavement from road edge to property line.

4.15.1.2. The maximum driveway widths as per drawing C15, attached.

4.15.1.3. The Maximum driveway width is the greater of:

- a) The relevant width indicated in Drawing C15, or
- b) 50% of the lot frontage if the frontage exceeds 12.0m to a maximum of 8.0 m or
- c) 7.5m for dwellings with suites or on lots whose zoning permits suites, if all off street parking requirements can be met and as approved by Development Permit, to a maximum driveway width of 8.0m at the property line.

4.15.1.4. A driveway access will not be permitted within 7.5m measured from the edge of the driveway to the edge of the closest curb return.

4.15.1.5. Driveways shall be minimum 1.2m from any street tree, streetlight, fire hydrant, utility kiosk or any above ground structure within the right of way, unless the utility can be protected by a bollard or curb to the satisfaction of the City Engineer. Water meters are not permitted within the driveway. All other requirements for individual utility providers must be met. (Bylaw No. 1574)

4.15.1.6. Proposed driveways shall be shown on the design review drawings.

- 4.15.1.7. A Bylaw 33 permit for driveway construction from the curb to the property line shall accompany all building permits, and is required for modification to existing driveways and addition of new driveways within the road right of way.

4.16. Cul de Sac Road Specifications

- 4.16.1. The length of a cul de sac road may not exceed 305 metres measured from the centreline of the intersection highway to the centre of the cul de sac bulb.
- 4.16.2. Notwithstanding the above, the length of a cul de sac may not exceed 183 metres in areas of extreme hazard severity classification as identified in the wild land/urban interface and urban/urban intermix assessment in Chapter 2 of NFPA299 1997 edition as amended.
- 4.16.3. The cul de sac bulb right-of-way radius shall be 15.0 metres with a paved surface radius of 13.0 metres and as shown in MMCD Supplement RS1.
- 4.16.4. The cul de sac bulb shall have an island located at the center of the bulb. Parking spaces within cul de sac islands shall be provided. Parking spaces shall be delineated by line painting.
- 4.16.5. Cul de sac islands shall be in-filled with 150mm thick coloured stamped concrete in a brick paver design or landscaped. If landscaping is selected for cul de sac islands, it shall be approved by the City Parks Manager.
- 4.16.6. The City Engineer may approve a temporary two point turn in lieu of a cul de sac for local roads less than 120 metres in length and the geometry is approved by the Fire Chief for emergency access if the road is to be extended in the foreseeable future. The road must be appropriately signed for fire access and shall substantially comply with the Building Bylaw for geometry.
- 4.16.7. Where roads are designed to a roads cross section:
 - 4.16.7.1 The road must be designated with a maximum speed of 50km/h or as specified by the City Engineer.
 - 4.16.7.2 For all cul-de-sacs, the radius of paved surface is to be a minimum of 13.0m in a 15.0m radius right of way.
- 4.16.8. Local road and access lanes are permitted to a maximum of 45m in length with no turn around when accessed via a local road only and approved by the Fire Chief. (Bylaw No. 1669)

4.17. Emergency Access

- 4.17.1. Any portion of any road constructed under this bylaw must be within 305 metres of a highway that has two routes available to emergency vehicles to access that point on the highway. These routes shall be constructed in accordance with the City of Langford Building Bylaw or a higher standard and may be constructed on private land provided that they are protected by a statutory right-of-way for emergency access in favour of the City of Langford. The maximum length of road allowed past the emergency access road is 183m.
- 4.17.2. Emergency fire, police and medical access must be available to every parcel within a subdivision or development in accordance with the following criteria and City of Langford Building Bylaw.
- 4.17.3. An emergency access plan must be evident on the construction drawings and be reviewed by the City of Langford Fire Chief prior to approval. The plan must show how emergency access routes will be protected and what, if any signage will be provided by the developer.
- 4.17.4. A emergency access road may be greater than 12% grade, but not more than 14% for 100 metres or more if, in the opinion of the City Engineer, a fire-fighting staging area can be reasonably provided. The City Engineer and Fire Chief may waive any of the requirements of this section if they each determine that the overall emergency access plan for the subdivision is acceptable.
- 4.17.5. Fire hydrants shall be located within 10 metres of fire fighting staging areas.
- 4.17.6. If fire staging areas are required as part of the overall emergency access plan approved by the Fire Chief for the development, they shall be a minimum of 8 metres long (measured in the direction of travel) by a minimum of 6 metres wide and have a maximum grade of 6% in any direction. The staging area must have drive-in access for a fire truck from the adjacent road. (Bylaw No. 1669)
- 4.17.7. Where the fire-fighting staging area is located on private property it must be protected by a right-of-way. The developer must provide breakaway bollards that must not cause any delay in access, as well as signage to prohibit parking or other obstruction of the fire-fighting staging area.
- 4.17.8. The subdivision or development plan must show driveway grades that have a maximum 6% grade for 4 metres of driveway directly adjacent to the proposed building for emergency medical access.

4.18. Street Lighting

- 4.18.1. All public highways and hard surfaced walkways shall have street lighting installed. (Bylaw No. 1618)
 - 4.18.1.1. The type, colour and standard of street light shall be in accordance with the applicable road cross section for the location of the development.

- 4.18.1.2. All wiring to service these lights shall be installed underground in ducts and labelled in the junction box.
- 4.18.1.3. Lighting shall be designed by a Professional Engineer for any public street lighting on collector and arterial roads and at local road intersections with the above noted classifications.
- 4.18.1.4. Designer to consider wattage and distribution to avoid lighting trespass.
- 4.18.1.5. The design shall not consider existing BC Hydro davit arms and are to note their removal on the design drawings. (Bylaw No. 1618)
- 4.18.1.6. Conduits must be extended to the limits of the project and contain a string in the junction box.
- 4.18.1.7. Designer must confirm no overhead or underground conflicts prior to construction.
- 4.18.1.8. Lighting levels shall be in accordance with the most recent edition American National Standard for Roadway Lighting published by Illuminating Engineering Society of North America.
- 4.18.1.9. For trails and walkways that are not adjacent to roadways, low mount pedestrian lighting such as bollards is permitted.
- 4.18.1.10. Nothing shall be attached in any manner to a streetlight pole or base with out the permission of the City Engineer.
- 4.18.1.11. Davit ('cobra') overhead street lighting shall use GE Evolve light-emitting diode (LED) lighting fixtures, Refer to the Approved Product List for model numbers.

This requirement may be waived by the City Engineer should the lighting be installed in an area of existing high-pressure sodium (HPS) lighting. In areas where HPS lighting is required, designs are to use Philips Lumec Helios Series fixtures. (Bylaw Nos. 1618, 1669, 1817)

- 4.18.2. Construction shall be in accordance with MMCD and BC Electrical code published by Technical Safety BC.
- 4.18.3. Streetlight installations shall have a controller base with a secure lockable compartment, provided in accordance with the manufacturer's specifications and as noted on Drawing E9, unless the new streetlights are connecting to an existing circuit with a controller base.
- 4.18.4. The controller base shall include on/off/auto switch, photo cell override and a hydro disconnect.. The on/off/override switch and panel shall be designed to accommodate the

number of lights in the circuit as well as seasonal lighting and be upgradeable for future extensions.

4.18.5. Concrete Bases

- 4.18.5.1. Shall be in accordance with MMCD: Type B for post-top lights; Type C for ornamental streetlights; and Type C for davit ('cobra') overhead streetlights. (Bylaw No. 1817)
- 4.18.5.2. The City Engineer may approve a poured in place concrete base if site conditions preclude the installation of a pre-cast concrete base. Poured in place concrete base must be designed and certified by the Professional Engineer.
- 4.18.6. Where traffic signals, electrical outlets, irrigation timers, signage or other forms of infrastructure other than a streetlight require electrical power, then a BC Hydro approved metered service is required, refer to the Approved Product List. In instances where the estimated power consumption is very minor and a separate BC Hydro meter is not economically warranted, the City may approve an alternate solution, for example battery power or sub-meters from adjoining private services. (Bylaw Nos. 1669, 1817)
- 4.18.7. Electrical outlets are required for all davit (cobra) streetlights unless waived by City Engineer.
- 4.18.8. In cases where the streetlighting might be extended, the City Engineer may require the conduits to be upsized.
- 4.18.9. All streetlights to be fitted with an anti-cycling device.
- 4.18.10. Streetlights must be fitted with an appropriate baffle or shield to deflect light away from private residences without compromising the effectiveness of the light on roads and walkways.
- 4.18.11. All streetlights requiring banner arms shall have the banners supplied and installed at the time of streetlight installation.
- 4.18.12. Deleted by Bylaw No. 2103.
- 4.18.13. Drawings:
 - 4.18.13.1. All submission and as constructed drawings must include:
 - 4.18.13.1.1. Controller base locations
 - 4.18.13.1.2. Photo cell locations
 - 4.18.13.1.3. Power source locations
 - 4.18.13.1.4. Illuminance drawings showing isoline levels

- 4.18.13.1.5. Table showing IESNA lighting design criteria and design achieved illumination levels and uniformity (Bylaw No. 1618)
 - 4.18.13.1.6. Volt drop calculations
 - 4.18.13.1.7. Conduit and wiring size
- 4.18.14. Construction Acceptance for all streetlighting will require: (Bylaw No. 1494)
- 4.18.14.1. Provincial electrical declaration.
 - 4.18.14.2. Summary of connected loads.
 - 4.18.14.3. All lights must be energized and functioning.
 - 4.18.14.4. Inspection record and electrical as-builts.
- 4.19. Hot-Mix Asphalt Concrete Paving Testing Intervals:
- 4.19.1 Documentation from the asphalt plant shall be provided for all projects (this will include reference to the mix design type for the material provided and the most recent applicable mix test report(s)).
 - 4.19.2 Asphalt sampling at paver:
 - 4.19.2.1 One sample shall be taken each day of operation. If the amount of asphalt concrete mix placed exceeds 500 tonnes (metric), an additional sample shall be collected each time after that limit is reached. These sampling requirements shall be adhered to unless specified and recorded otherwise at the project pre-construction meeting.
 - 4.19.2.2 A Marshall Test Report shall be provided for each sample taken.
 - 4.19.3 The project Engineer shall provide certification for both the final product and all works and services. Refer to work requirements in MMCD.
 - 4.19.4 Core testing shall be performed upon project completion to verify asphalt thickness and density. The requirement for core testing may be adjusted or waived at the discretion of the City Engineer.
- 4.20 Case-in-Place Concrete Testing Intervals
- 4.20.1 Documentation Documentation from the concrete plant shall be provided for all projects (this will include mix design information and daily batch reports for the material provided).
 - 4.20.2 Concrete sampling at project location:

- 4.20.2.1 One sample shall be taken each day of operation. If the length of curb, gutter or sidewalk installed within one day exceeds 300m lineal or 100m³ (whichever is first), an additional sample shall be collected each time after that limit is reached. For all other installations, if the volume of concrete cast exceeds 100m³, an additional sample shall be collected each time after that limit is reached, unless the installation is a specialized poured-in place structure(s), in which case sampling shall be performed for every delivery.
 - 4.20.2.2 A Concrete Test Summary Report shall be provided for each sample taken.
 - 4.20.2.3 These sampling requirements shall be adhered to unless specified and recorded otherwise at the project pre-construction meeting. Additional sampling and testing may be required at the discretion of the City Engineer.
- 4.20.3 Deleted. (Bylaw No. 1669)

4.21 Bridges (Section added by Bylaw 1926):

- 4.21.1 All bridges must be designed in accordance with *Canadian Highway Bridge Design Code* (CHBDC) CSA S6:19 and the BC Ministry of Transportation and Infrastructure *Bridge Standards & Procedures Manual Volume 1 Supplement to CHBDC CSA S6:19*, or most recent versions thereof, with the following requirements all as approved by and to the satisfaction of the Director of Engineering:
 - (a) bridge structures shall be designed at minimum for BCL-625 live loading;
 - (b) bridge foundations shall be designed in accordance with the Professional Geotechnical Engineer of Record's authenticated recommendations;
 - (c) bridge elevations shall be designed in accordance with the approved stormwater management plan;
 - (d) bridge alignments shall be designed in accordance with Transportation Association of Canada's *Geometric Design Guide for Canadian Roads*; and
 - (e) bridge drawings provided for approval shall be at minimum authenticated by the Professional Structural Bridge Engineer of Record.
- 4.21.2 All relevant professional work products including but not limited to design drawings and geotechnical reports submitted for approval are to be authenticated in accordance with the Engineers and Geoscientists BC's *Guide to the Standard Authentication of Documents*.
 - 4.21.2.1 Bridge submittals for approval must confirm at minimum: continuity of the approved road cross-section, vertical/horizontal road alignment continuity, the design standards and maximum loading, geotechnical and seismic compliance, bridge abutment and bank protection, high-water level and freeboard, utility crossing locations and ducts, and public safety features including but not limited to curbs, barriers, bridgerail, guardrail, handrail, or fencing as appropriate.
 - 4.21.2.2 Submittal reviews completed by City staff are cursory and checked only for general compliance with City bylaws and asset management/maintenance purposes and shall not relieve the Engineer or Geoscientist of Record or the

applicant from their responsibilities for errors or omissions, or of meeting any applicable requirements. The City assumes no responsibility for the design, including the accuracy of dimensions or details. Where applicable, the City's approval is contingent upon approval from the Ministry of Environment and the Department of Fisheries and Oceans for works over/within Streamside Protection and Enhancement Areas (SPEAs) or watercourses, and approval from the Ministry of Transportation and Infrastructure for works within 800 meters of a Provincial Highway.

TABLE 4-3 – ROAD AND STREETLIGHTING STANDARDS FOR BEAR MOUNTAIN

DWG #	LEVEL OF SERVICE	RIGHT OF WAY	MAX. LENGTH OF CUL DE SAC	TRAVELED SURFACE	CURB	SIDEWALK	STREET LIGHTS	OTHER
BM1	Local Urban & Cul-de-Sac Intensive Res.	12.0m	110.0m	6.0m	mountable	1.8m one side	Heritage single Black & gold One side	
BM2	Local Urban R2 Density	12.0m	100m	8.0m	mountable	2.0m one side	Heritage single Black & gold One side	
BM3	Local Urban & Cul-de-sac R2 Density	14.0m		8.0m	mountable	1.8m one side	Heritage single Black & gold One side	
BM4	Local Urban R2 Density	15.0m		8.0m	mountable	1.8m one side	Heritage single Black & gold One side	
BM5	Local Urban & Cul-de-Sac - Entrance Island	16.0m		36m + 3.6m	mountable	1.8m both sides	Heritage double Black & gold centre	Median with NMC
BM6	Rear lane	6.0m	n/a	5.0	Invert in centre 600mm	none	none	Invert crown
BM7	Bear Mtn. Pkwy. Minor Collector	18.4m	n/a	4.3m + 4.3m	Flat 300mm	1.8m one side	Heritage double Black & gold centre	Median with NMC
BM8	Bear Mtn. Pkwy. Minor Collector	18.4m	n/a	10.6m	Flat 300mm	1.8m one side	Heritage single Black & gold One side	No median
BM9	Bear Mtn. Pkwy. Minor Collector Split (southbound)	10.7m	n/a	4.3m one lane	Flat 300mm	none	Heritage single Black & gold One side	Wetland split
BM10	Bear Mtn. Pkwy. Minor Collector Split (northbound)	10.0m	n/a	4.3m one lane	Flat 300mm	1.8m one side	Heritage single Black & gold One side	Wetland split
BM11	Bear Mtn. Pkwy. Minor Collector Village Centre	24.5m	n/a	12.9m centre turn lane	Invert 600mm	2.0m both sides	Village standard	Landscaped median w/ centre lights possible

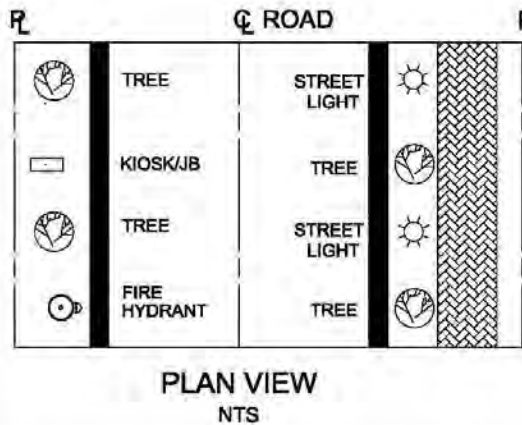
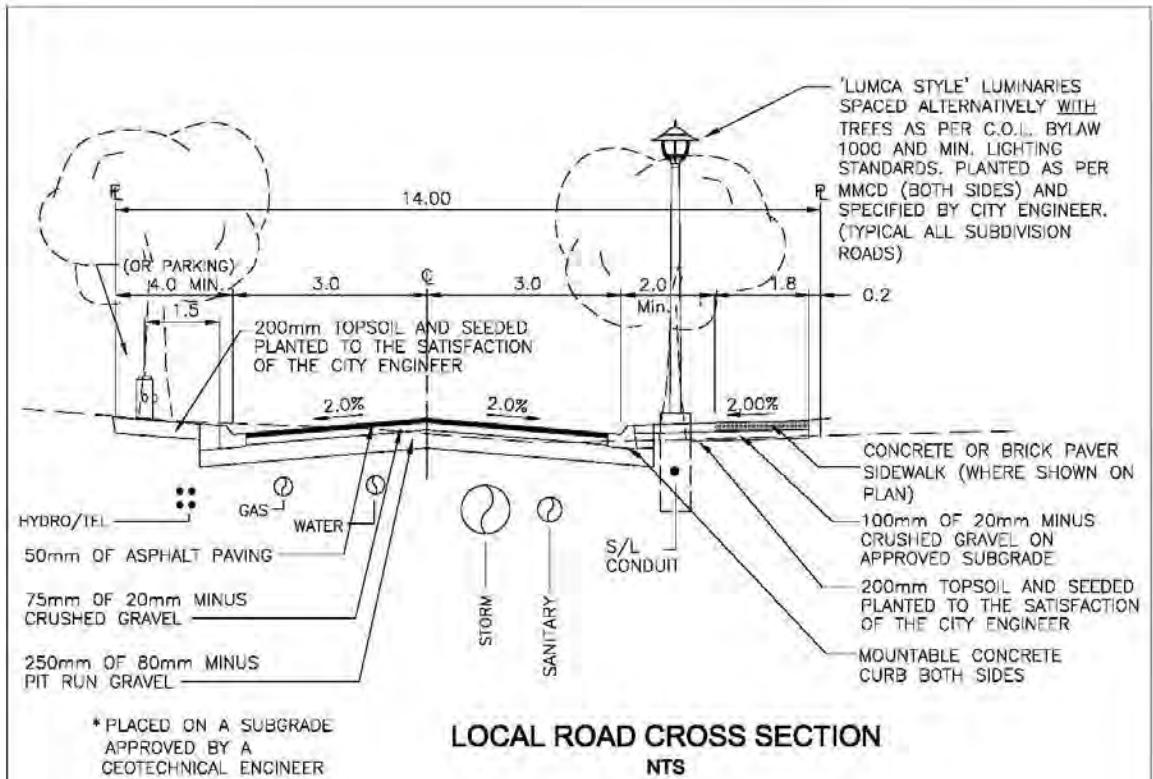

NOTES:

- SPECIAL DESIGN FOR TRAFFIC CALMING AS REQUIRED BY CITY ENGINEER
- SERVICES TO BE LOCATED AS SHOWN IN DRAWING.
- WATER**
 - MUST BE 1.5m CLEAR OF UNDERGROUND HYDRO.
 - MUST BE 3.0m CLEAR OF SANITARY & STORM SEWERS.
 - MUST BE 1.0m CLEAR OF LAMP STANDARD BASES.
- HYDRANTS**
 - MUST BE 3.0m CLEAR OF ANY ABOVE GROUND STRUCTURES AND LAMP STANDARDS.
 - LOCATION OF FIRE HYDRANT IN ACCORDANCE WITH FIRE PLAN.

BEAR MOUNTAIN ESTATES

14m R/W - 6m ROAD



**CITY OF LANGFORD
ENGINEERING DEPARTMENT**

DATE:
FEB 2004

DRAWN:
ID

DWG No.

SCALE:
NTS

APPROVED:
MM

BM1

Last Revised: Bylaw 1669, February 2017

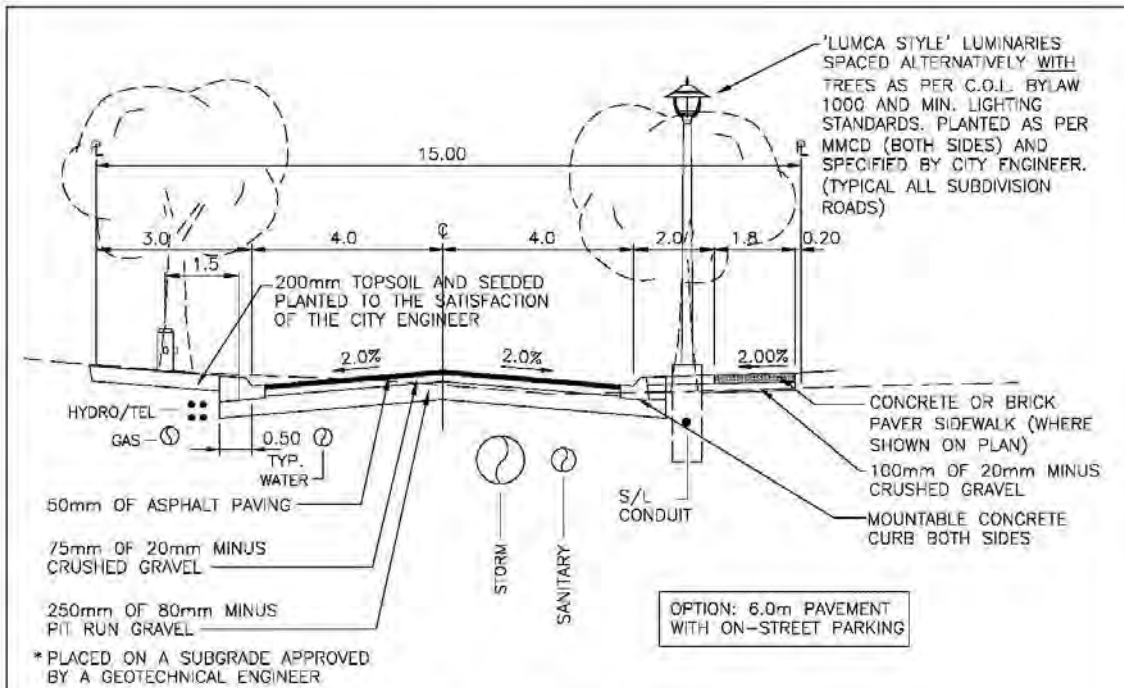

LOCAL ROAD CROSS SECTION
NTS

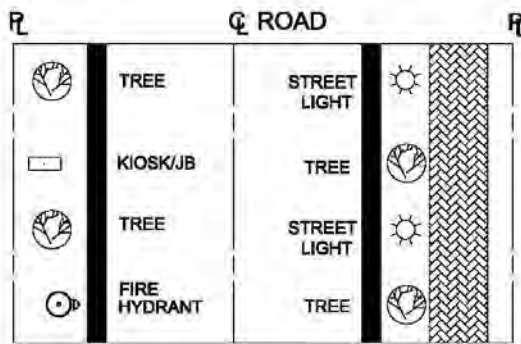

PLAN VIEW
NTS

NOTES:

- * SPECIAL DESIGN FOR TRAFFIC CALMING AS REQUIRED BY CITY ENGINEER.
 - * SERVICES TO BE LOCATED AS SHOWN IN DRAWING.
- WATER
- MUST BE 1.5m CLEAR OF UNDERGROUND HYDRO.
 - MUST BE 3.0m CLEAR OF SANITARY & STORM SEWERS.
 - MUST BE 1.0m CLEAR OF LAMP STANDARD BASES.
- HYDRANTS
- MUST BE 3.0m CLEAR OF ANY ABOVE GROUND STRUCTURES AND LAMP STANDARDS.
 - LOCATION OF FIRE HYDRANT IN ACCORDANCE WITH FIRE PLAN.

BEAR MOUNTAIN ESTATES

15m R/W - 8m ROAD



CITY OF LANGFORD
ENGINEERING DEPARTMENT

DATE:
FEB 2004

DRAWN:
ID

DWG No.

SCALE:
NTS

APPROVED:
MM

BM2

Lost Revised: Bylaw 1569, February 2017

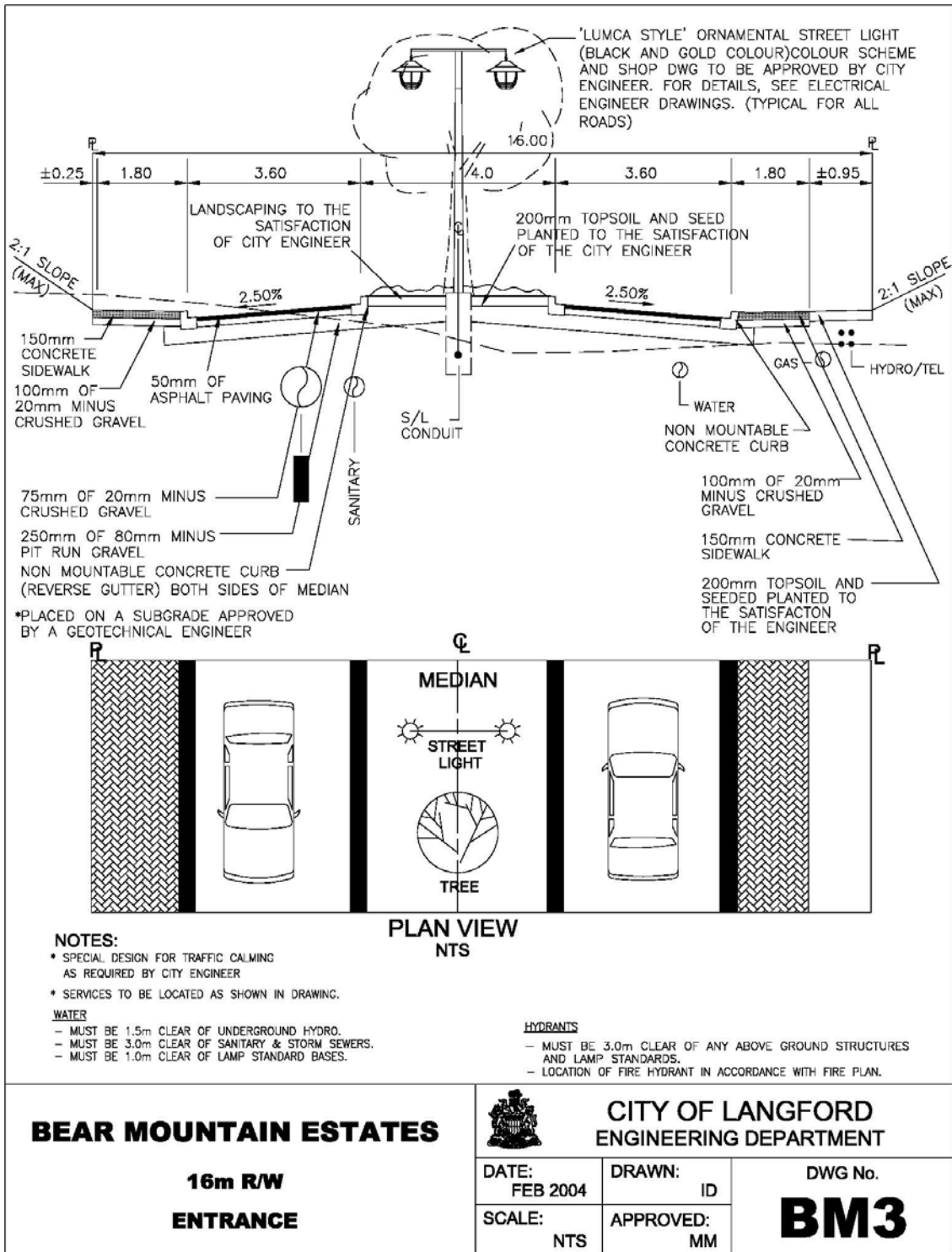

BEAR MOUNTAIN ESTATES

**16m R/W
ENTRANCE**



**CITY OF LANGFORD
ENGINEERING DEPARTMENT**

DATE:
FEB 2004

DRAWN:
ID

DWG No.

SCALE:
NTS

APPROVED:
MM

BM3

Last Revised: Bylaw 1669, February 2017

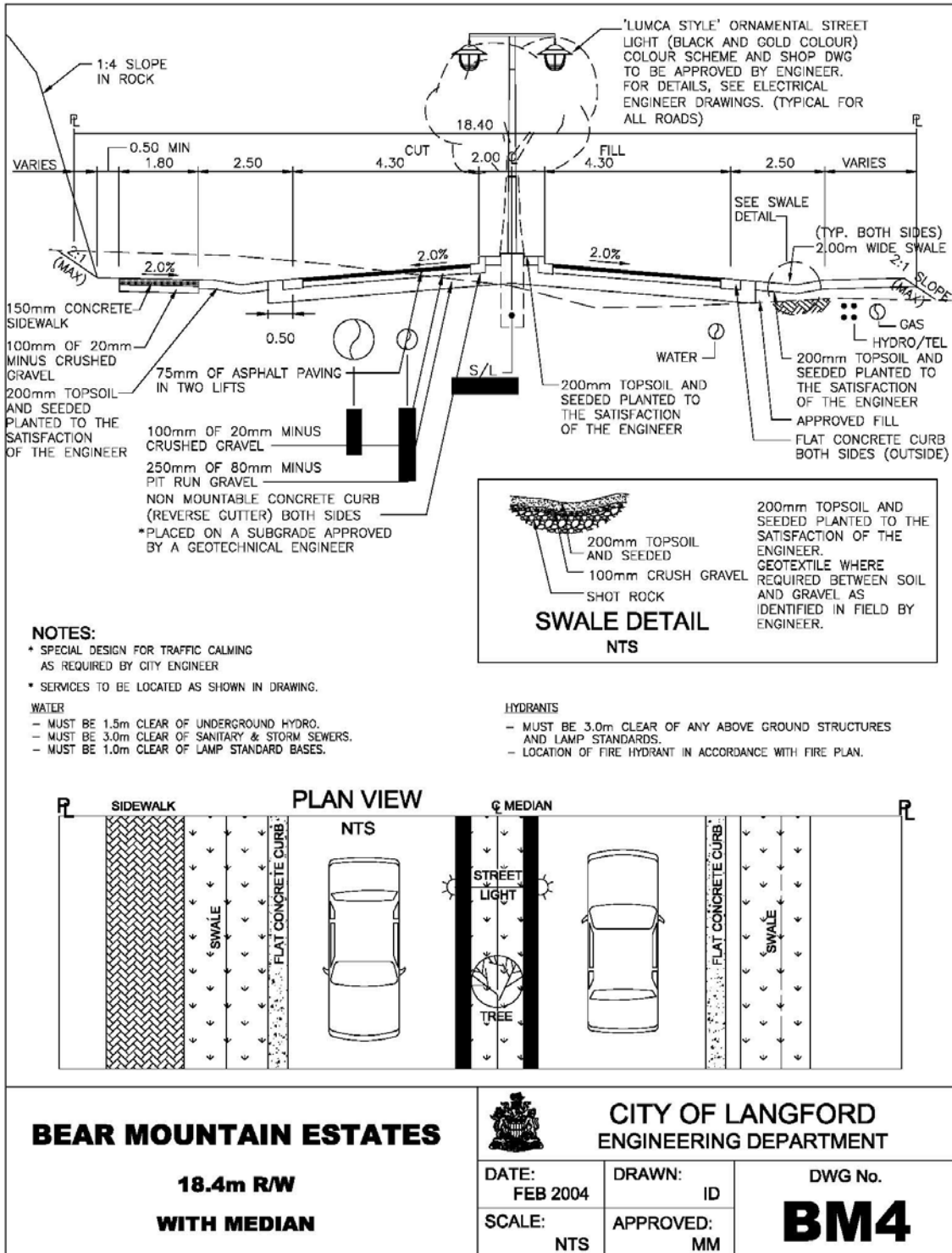

Last Revised: Bylaw 1669, February 2017

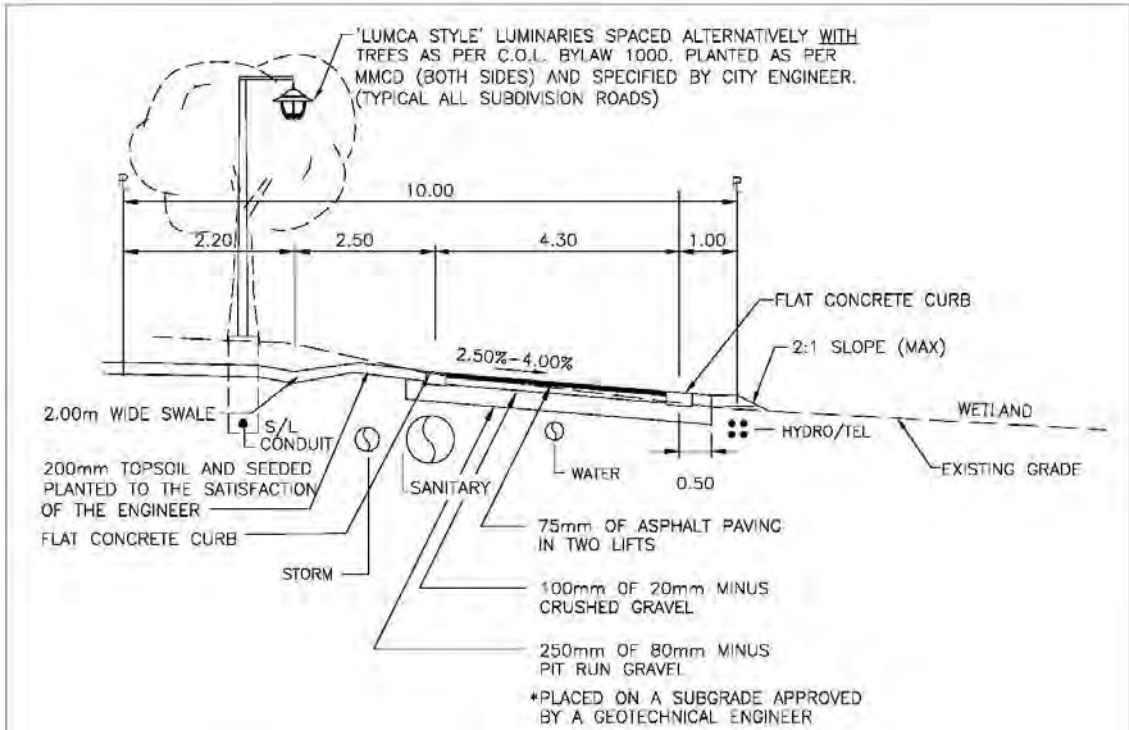

ROAD CROSS SECTION BEAR MOUNTAIN PARKWAY
NTS

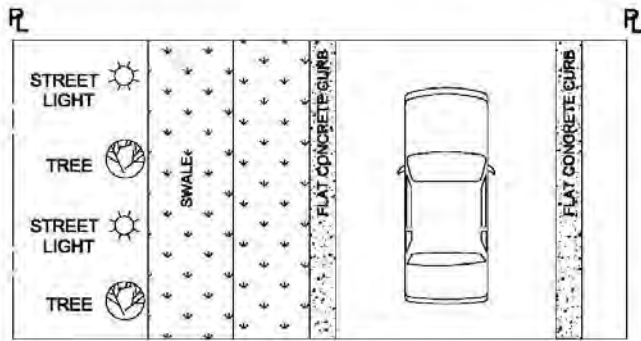

PLAN VIEW
NTS

NOTES:

- * SPECIAL DESIGN FOR TRAFFIC CALMING AS REQUIRED BY CITY ENGINEER
 - * SERVICES TO BE LOCATED AS SHOWN IN DRAWING.
- WATER**
- MUST BE 1.5m CLEAR OF UNDERGROUND HYDRO.
 - MUST BE 3.0m CLEAR OF SANITARY & STORM SEWERS.
 - MUST BE 1.0m CLEAR OF LAMP STANDARD BASES.
- HYDRANTS**
- MUST BE 3.0m CLEAR OF ANY ABOVE GROUND STRUCTURES AND LAMP STANDARDS.
 - LOCATION OF FIRE HYDRANT IN ACCORDANCE WITH FIRE PLAN.

BEAR MOUNTAIN ESTATES 10m R/W	 CITY OF LANGFORD ENGINEERING DEPARTMENT	
	DATE: FEB 2004	DRAWN: ID
SCALE: NTS	APPROVED: MM	DWG No. BM5

Last Revised: Bylaw 1669, February 2017

*LUMCA STYLE LUMINARIES SPACED ALTERNATIVELY WITH TREES AS PER C.O.L. BYLAW 1000. PLANTED AS PER MMCD (BOTH SIDES) AND SPECIFIED BY CITY ENGINEER. (TYPICAL ALL SUBDIVISION ROADS)

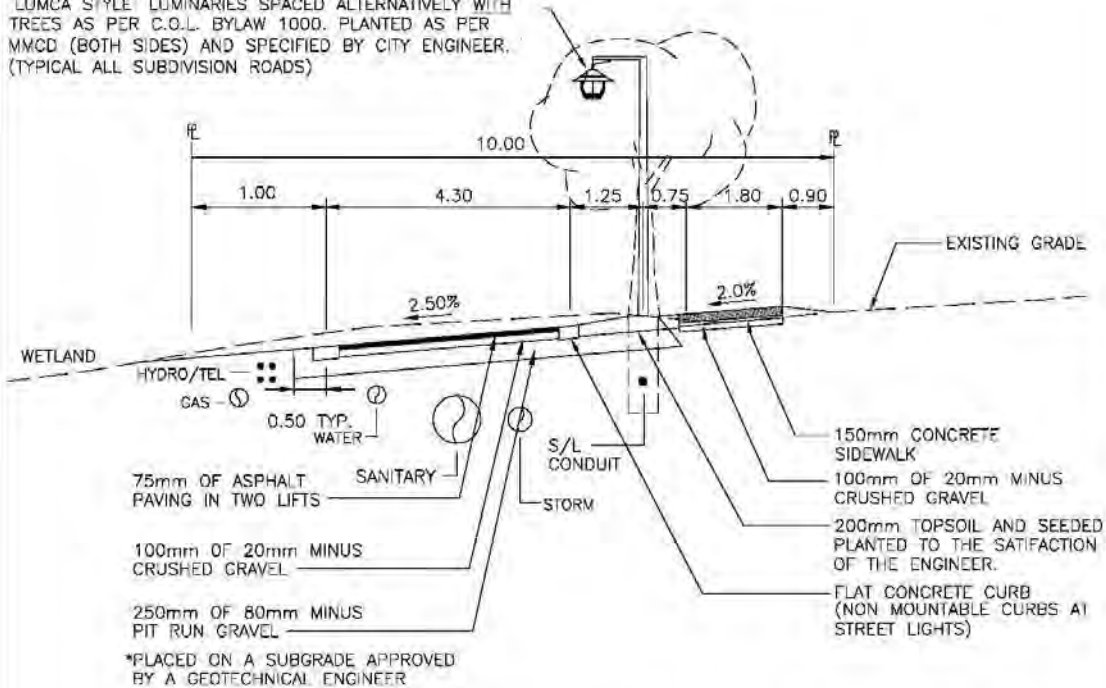

ROAD CROSS SECTION BEAR MOUNTAIN PARKWAY
NTS

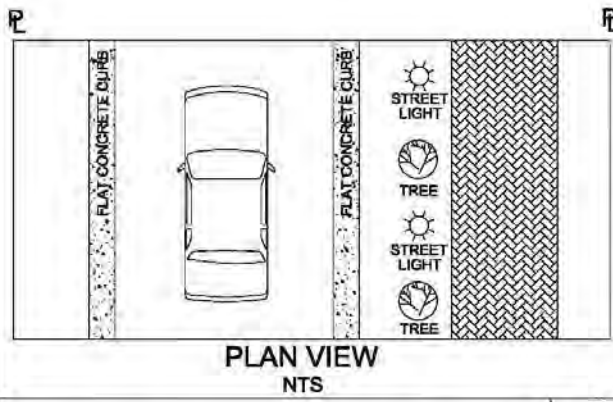

- NOTES:**
- * SPECIAL DESIGN FOR TRAFFIC CALMING AS REQUIRED BY CITY ENGINEER
 - * SERVICES TO BE LOCATED AS SHOWN IN DRAWING.
- WATER**
- MUST BE 1.5m CLEAR OF UNDERGROUND HYDRO.
 - MUST BE 3.0m CLEAR OF SANITARY & STORM SEWERS.
 - MUST BE 1.0m CLEAR OF LAMP STANDARD BASES.
- HYDRANTS**
- MUST BE 3.0m CLEAR OF ANY ABOVE GROUND STRUCTURES AND LAMP STANDARDS.
 - LOCATION OF FIRE HYDRANT IN ACCORDANCE WITH FIRE PLAN.

BEAR MOUNTAIN ESTATES 10m R/W		CITY OF LANGFORD ENGINEERING DEPARTMENT	
	DATE: FEB 2004	DRAWN: ID	DWG No. BM6
SCALE: NTS	APPROVED: MM		

Last Revised: Bylaw 1669, February 2017

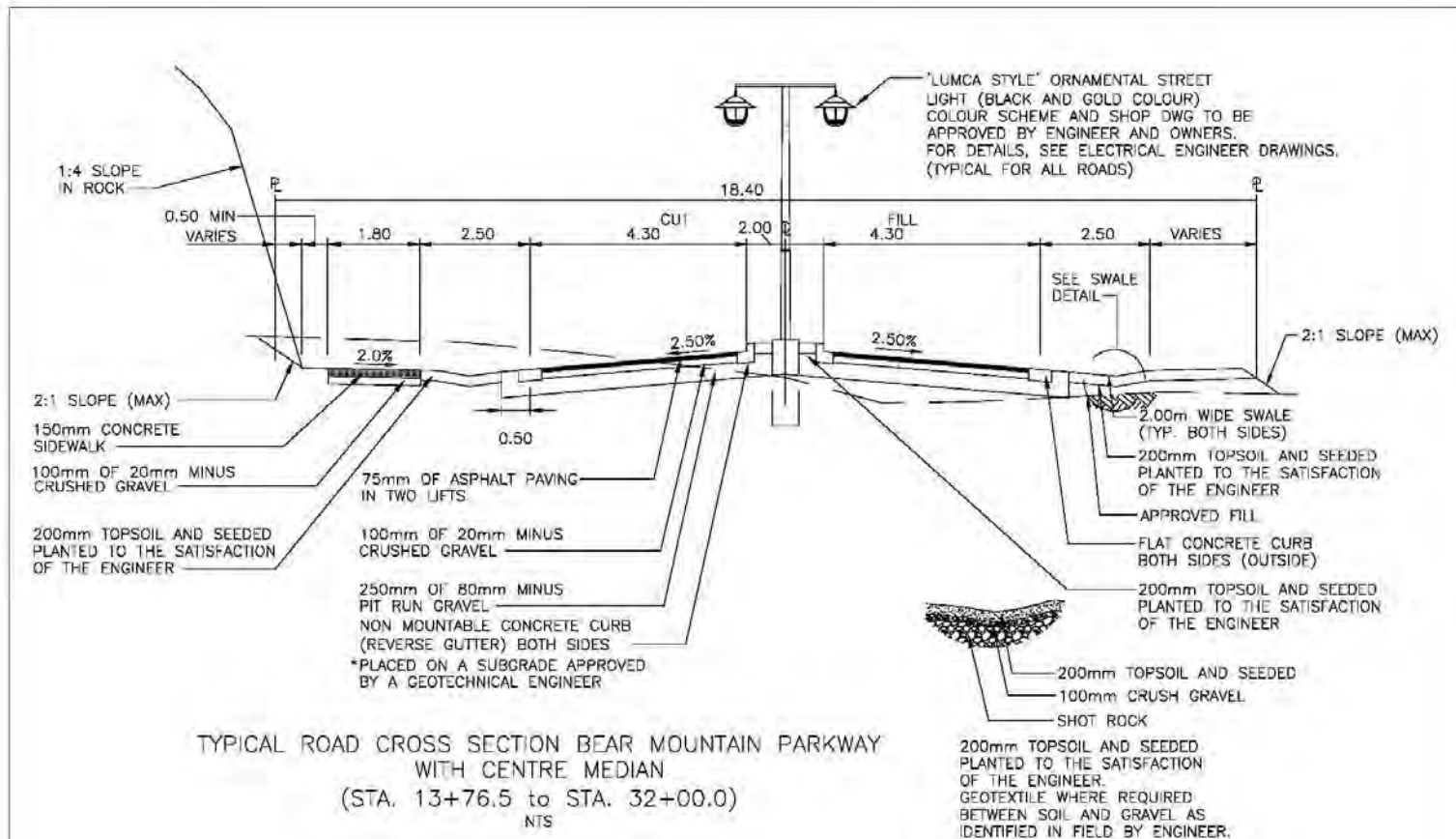

BEAR MOUNTAIN ESTATES 18.4m R/W WITH MEDIAN	 CITY OF LANGFORD ENGINEERING DEPARTMENT		
	DATE: FEB 2003	DRAWN: ID	DWG No. BM7
	SCALE: NTS	APPROVED: MM	

Last Revised: Bylaw 1669, February 2017

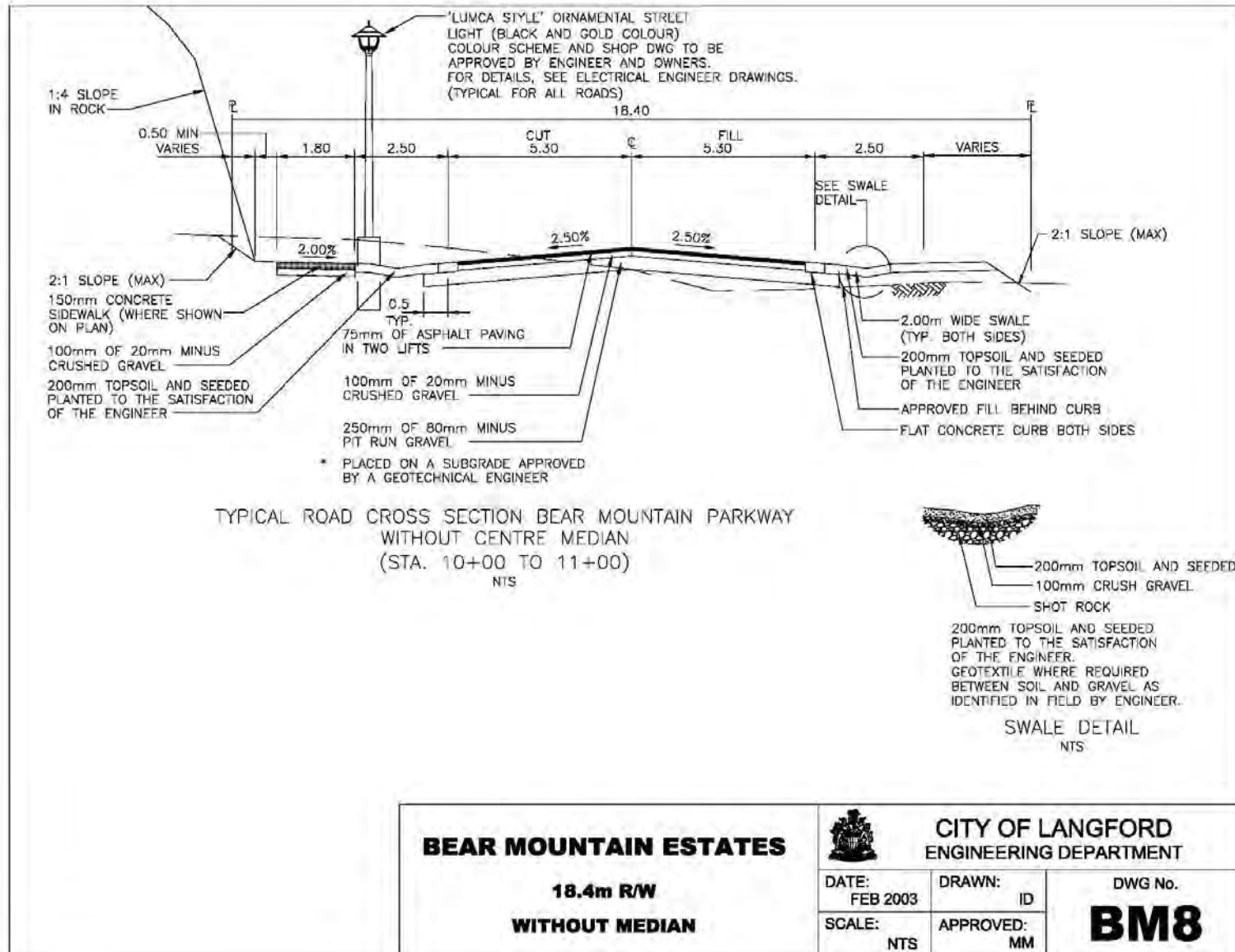

Last Revised: Bylaw 1669, February 2017

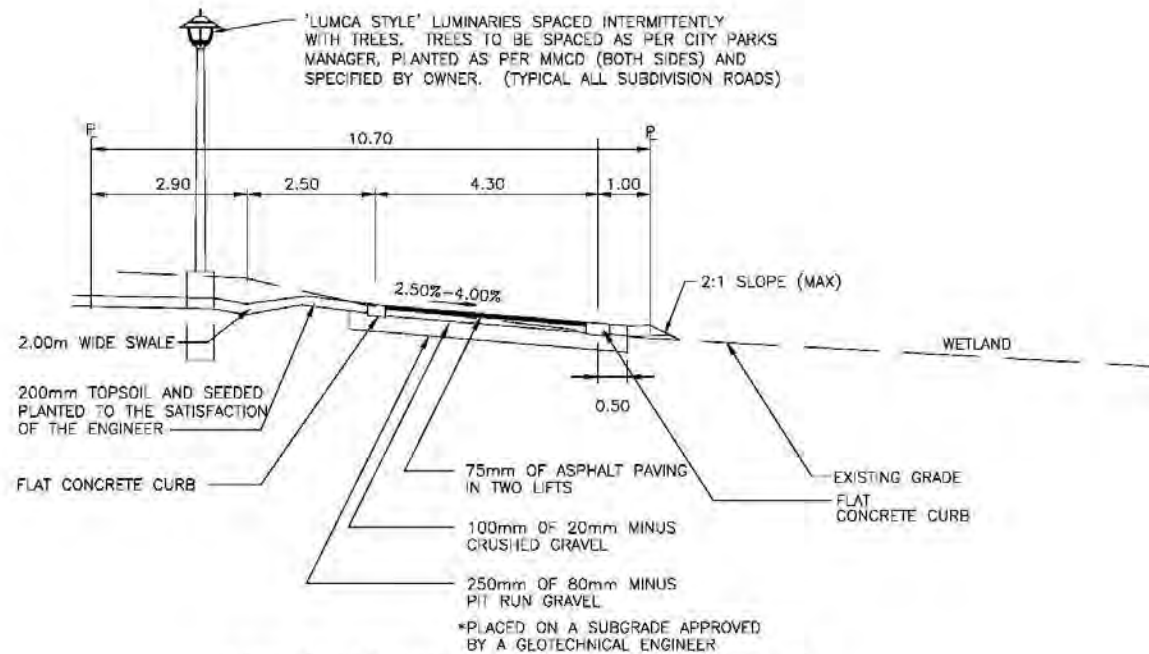

ROAD CROSS SECTION BEAR MOUNTAIN PARKWAY
SOUTHBOUND AROUND WETLAND
(STA. 1+00.0 to STA. 4+53.5)
NTS

BEAR MOUNTAIN ESTATES

10.70 R/W



**CITY OF LANGFORD
ENGINEERING DEPARTMENT**

DATE:
FEB 2003

DRAWN:
ID

DWG No.

SCALE:
NTS

APPROVED:
MM

BM9

Last Revised: Bylaw 1669, February 2017

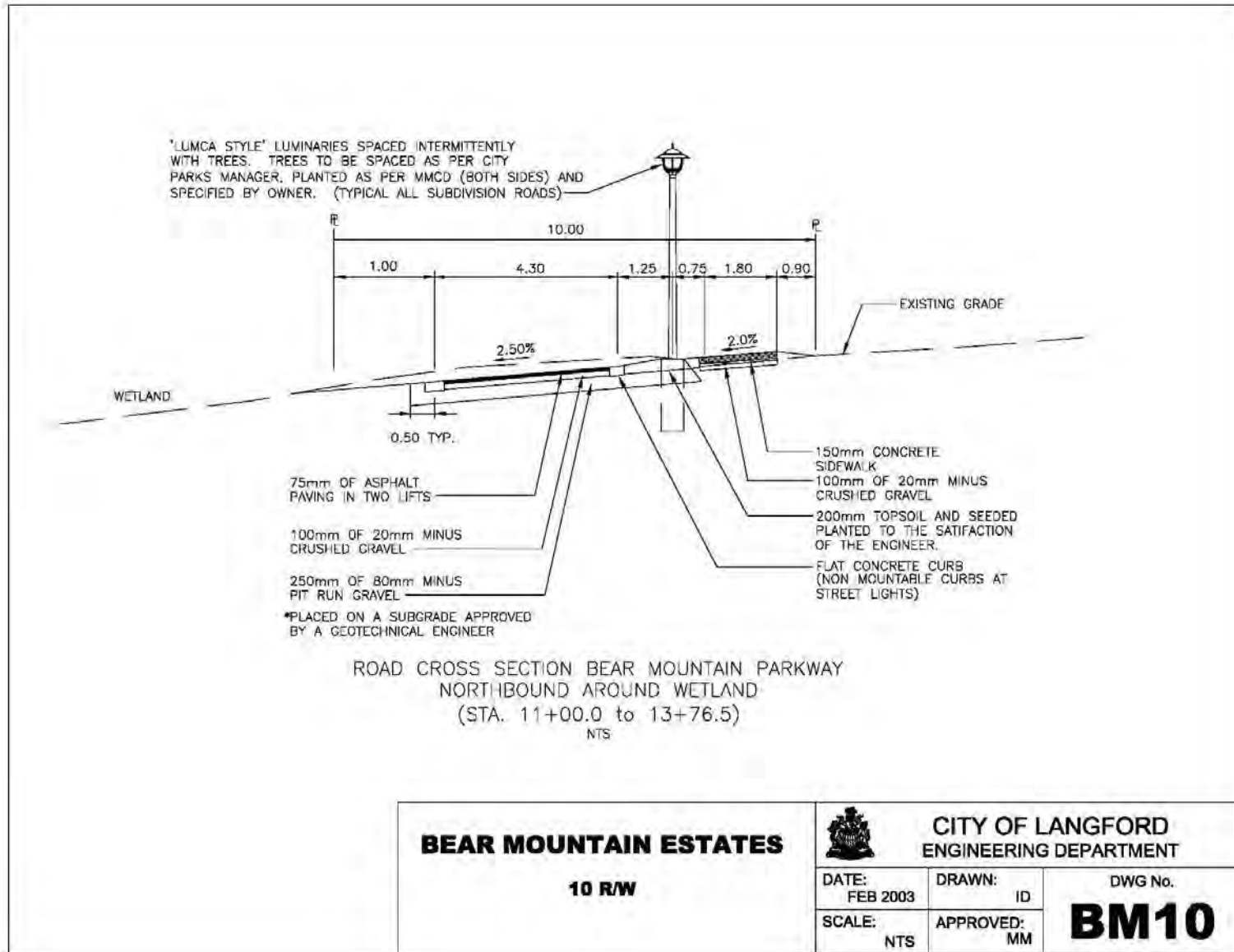

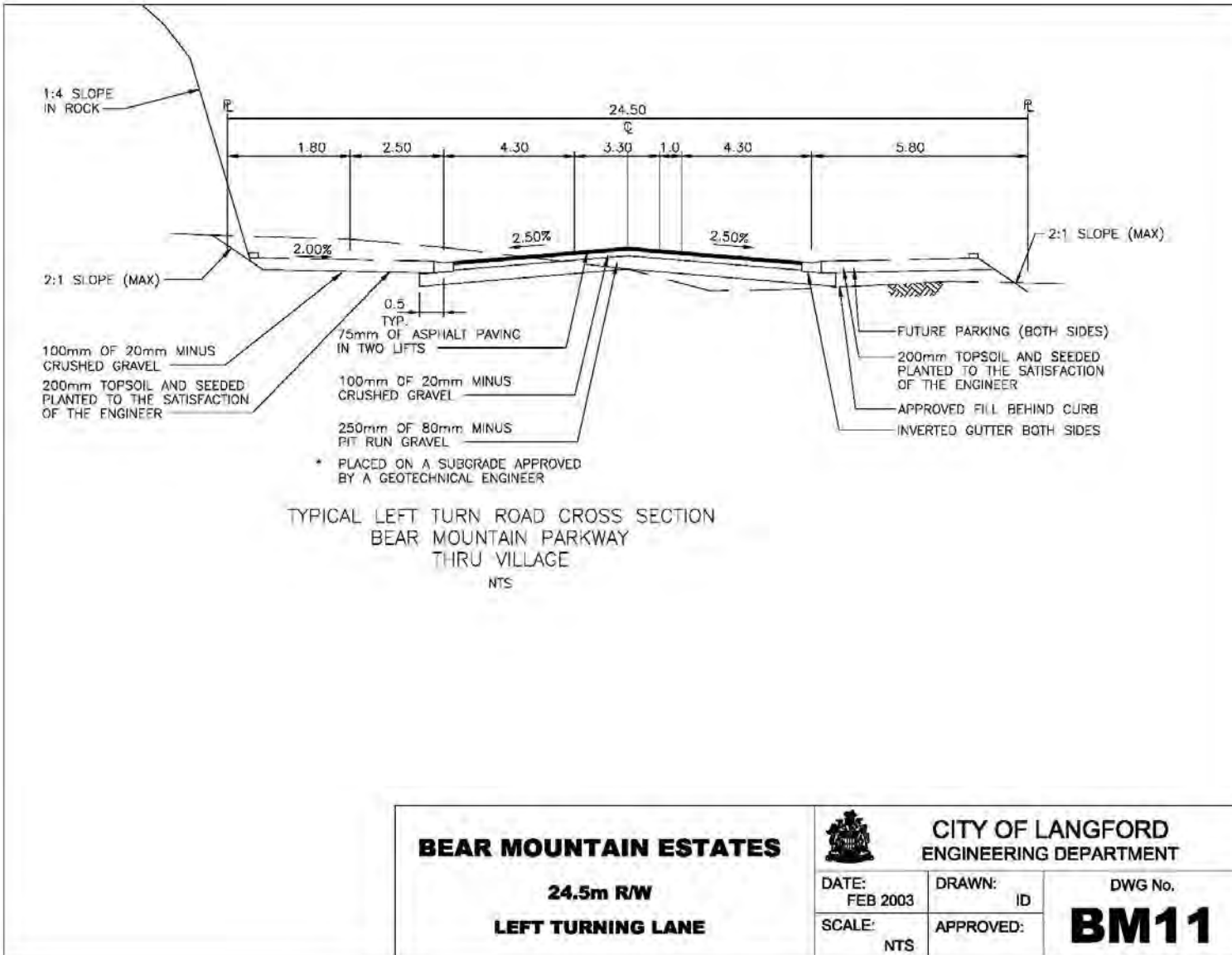

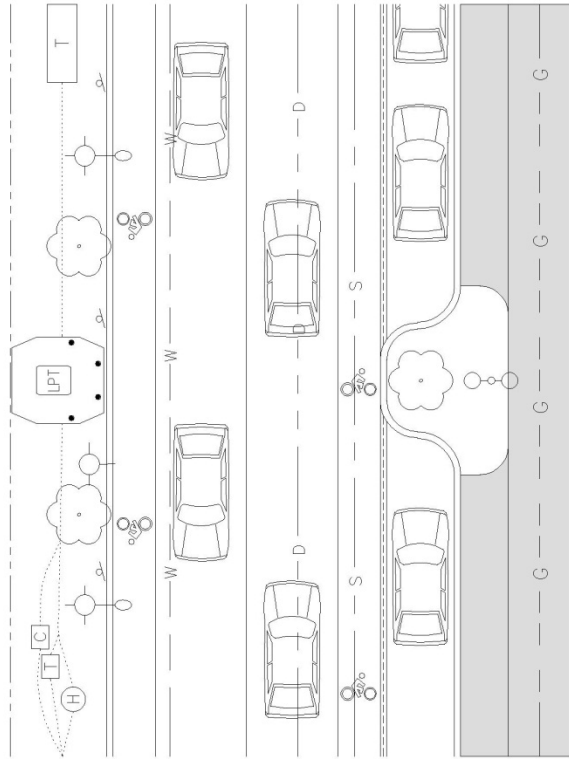
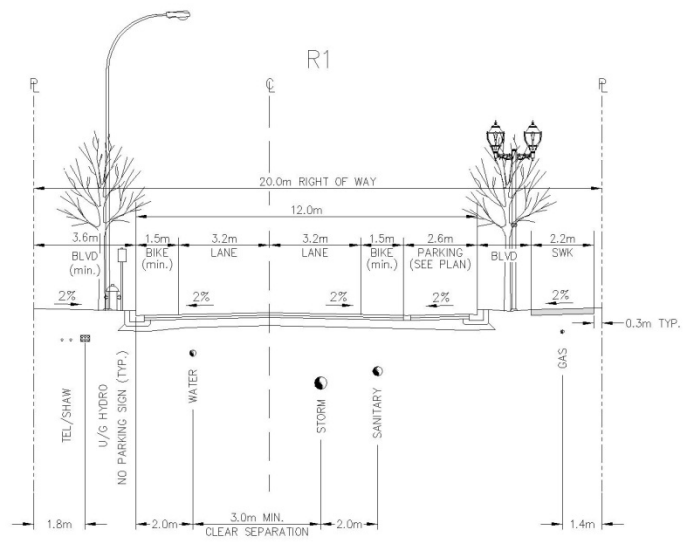

- NOTES:**
1. NO DRIVEWAYS SHOWN AS ROADWAY IS CONTROLLED ACCESS. ACCESS UNDER APPROVAL OF CITY ENGINEER.
 2. BIKE LANES TO BE INCREASED TO 1.8m ON INCLINES GREATER THAN 5%
 3. TREE, HYDRANT AND LIGHT TREE PLACEMENT SUBJECT TO DESIGN. SHOWN SCHEMATICALLY.

**URBAN COLLECTOR
2 LANES + PARKING, 20m ROW**



**CITY OF LANGFORD
ENGINEERING DEPARTMENT**

DATE: 01-Dec-10

DRAWN: TWB

DWG No.

SCALE: NTS

APPROVED:

R1

Last Revised: Jan 7, 2011

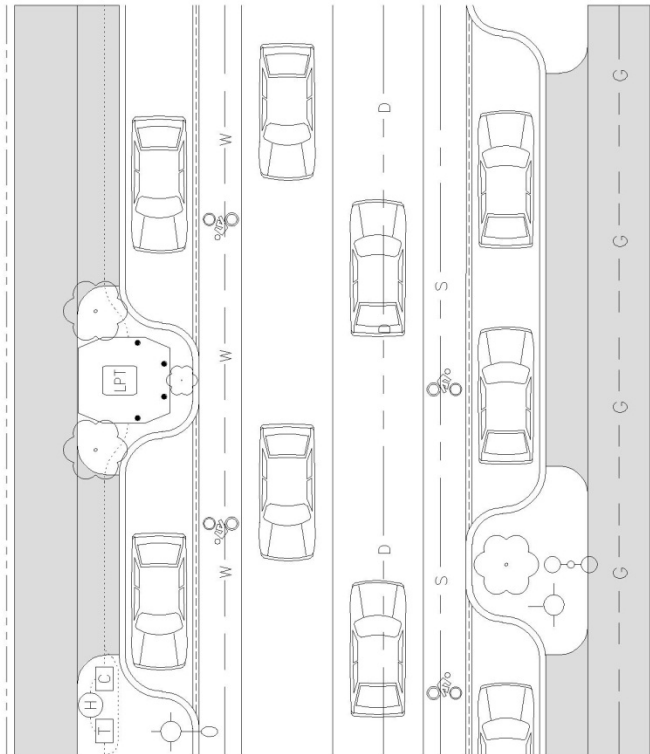
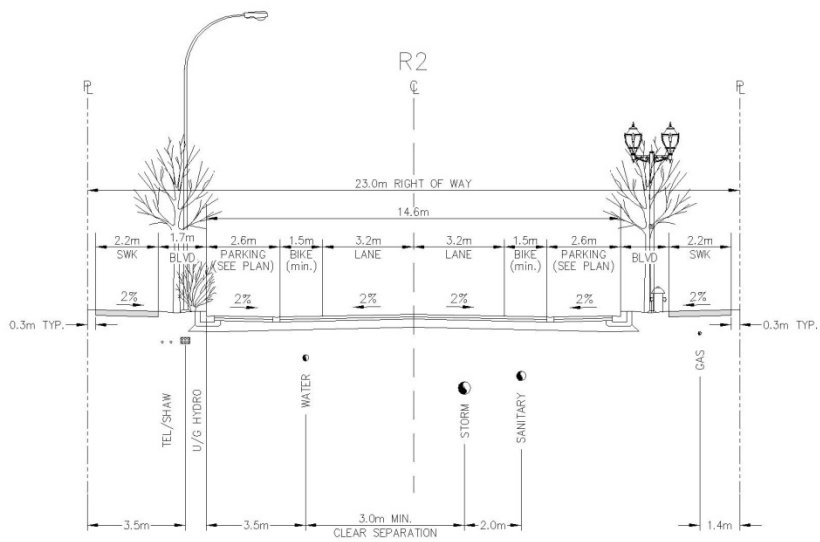

NOTES:

1. NO DRIVEWAYS SHOWN AS ROADWAY IS CONTROLLED ACCESS. ACCESS UNDER APPROVAL OF CITY ENGINEER.
2. BIKE LANES TO BE INCREASED TO 1.8m ON INCLINES GREATER THAN 5%
3. TREE, HYDRANT AND LIGHT PLACEMENT SUBJECT TO DESIGN. SHOWN SCHEMATICALLY.

**URBAN COLLECTOR
2 LANES + PARKING, 23m ROW**



**CITY OF LANGFORD
ENGINEERING DEPARTMENT**

DATE: 01-Dec-10	DRAWN: TWB	DWG No. R2
SCALE: NTS	APPROVED:	

Last Revised: Jan 7, 2011

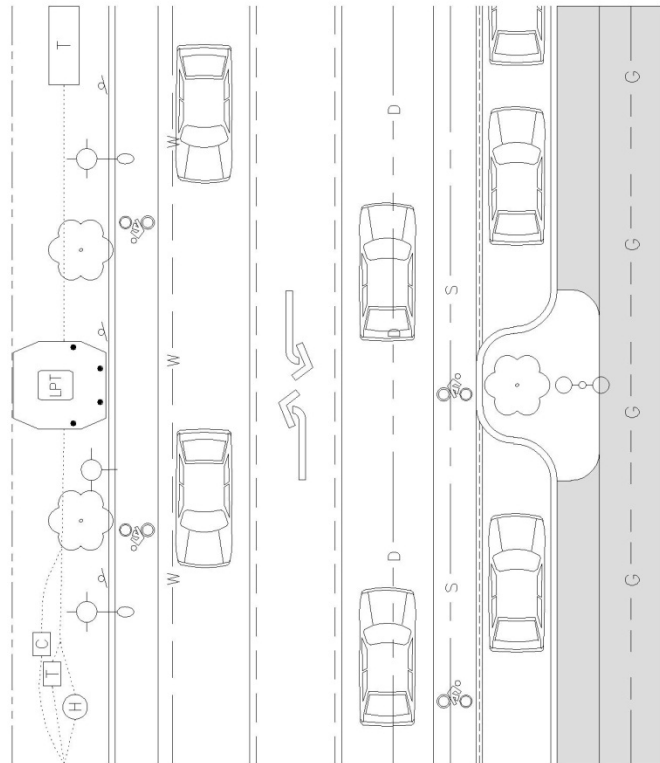
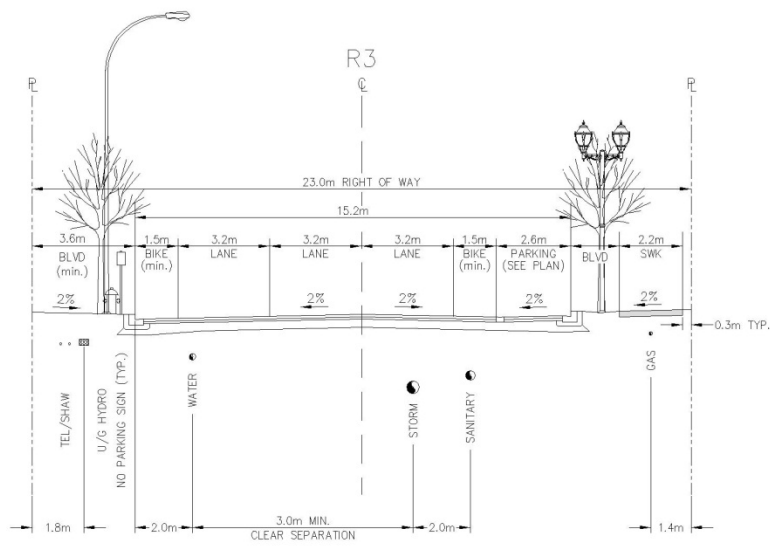

- NOTES:**
1. NO DRIVEWAYS SHOWN AS ROADWAY IS CONTROLLED ACCESS. ACCESS UNDER APPROVAL OF CITY ENGINEER.
 2. BIKE LANES TO BE INCREASED TO 1.8m ON INCLINES GREATER THAN 5%
 3. TREE, HYDRANT AND LIGHT PLACEMENT SUBJECT TO DESIGN. SHOWN SCHEMATICALLY.

**URBAN COLLECTOR
3 LANES - 23m ROW, 1 SWK**



**CITY OF LANGFORD
ENGINEERING DEPARTMENT**

DATE: 01-Dec-10	DRAWN: TWB	DWG No. R3
SCALE: NTS	APPROVED:	

Last Revised: Jan 7, 2011

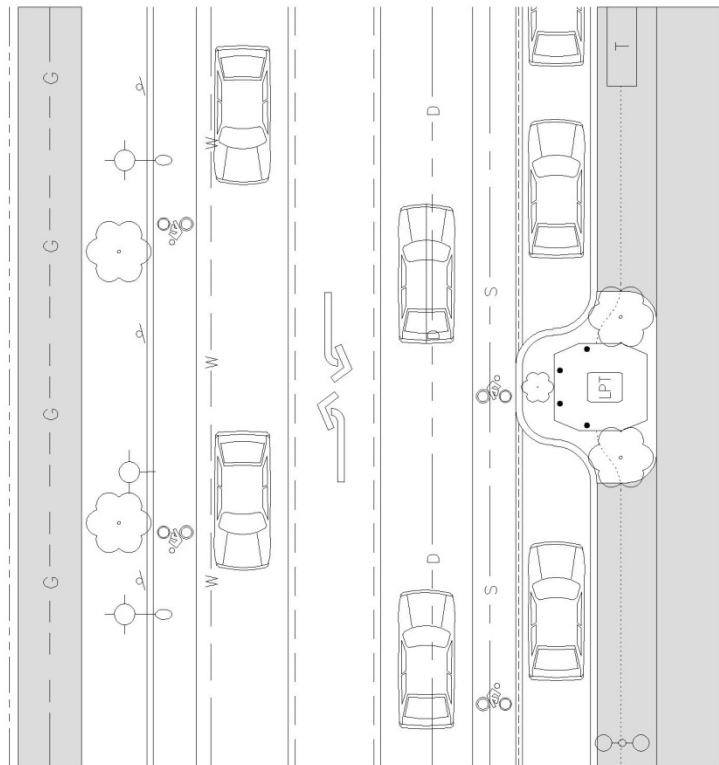
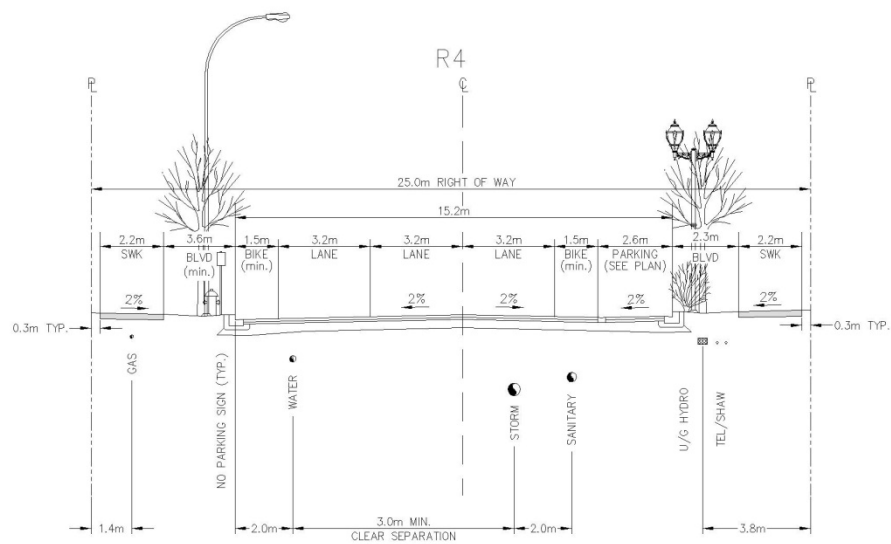

- NOTES:**
1. NO DRIVEWAYS SHOWN AS ROADWAY IS CONTROLLED ACCESS. ACCESS UNDER APPROVAL OF CITY ENGINEER.
 2. BIKE LANES TO BE INCREASED TO 1.8m ON INCLINES GREATER THAN 5%
 3. TREE, HYDRANT AND LIGHT PLACEMENT SUBJECT TO DESIGN. SHOWN SCHEMATICALLY.

**URBAN COLLECTOR
3 LANES - 25.0m ROW**



**CITY OF LANGFORD
ENGINEERING DEPARTMENT**

DATE: 01-Dec-10	DRAWN: TWB	DWG No. R4
SCALE: NTS	APPROVED:	

Last Revised: Jan 7, 2011

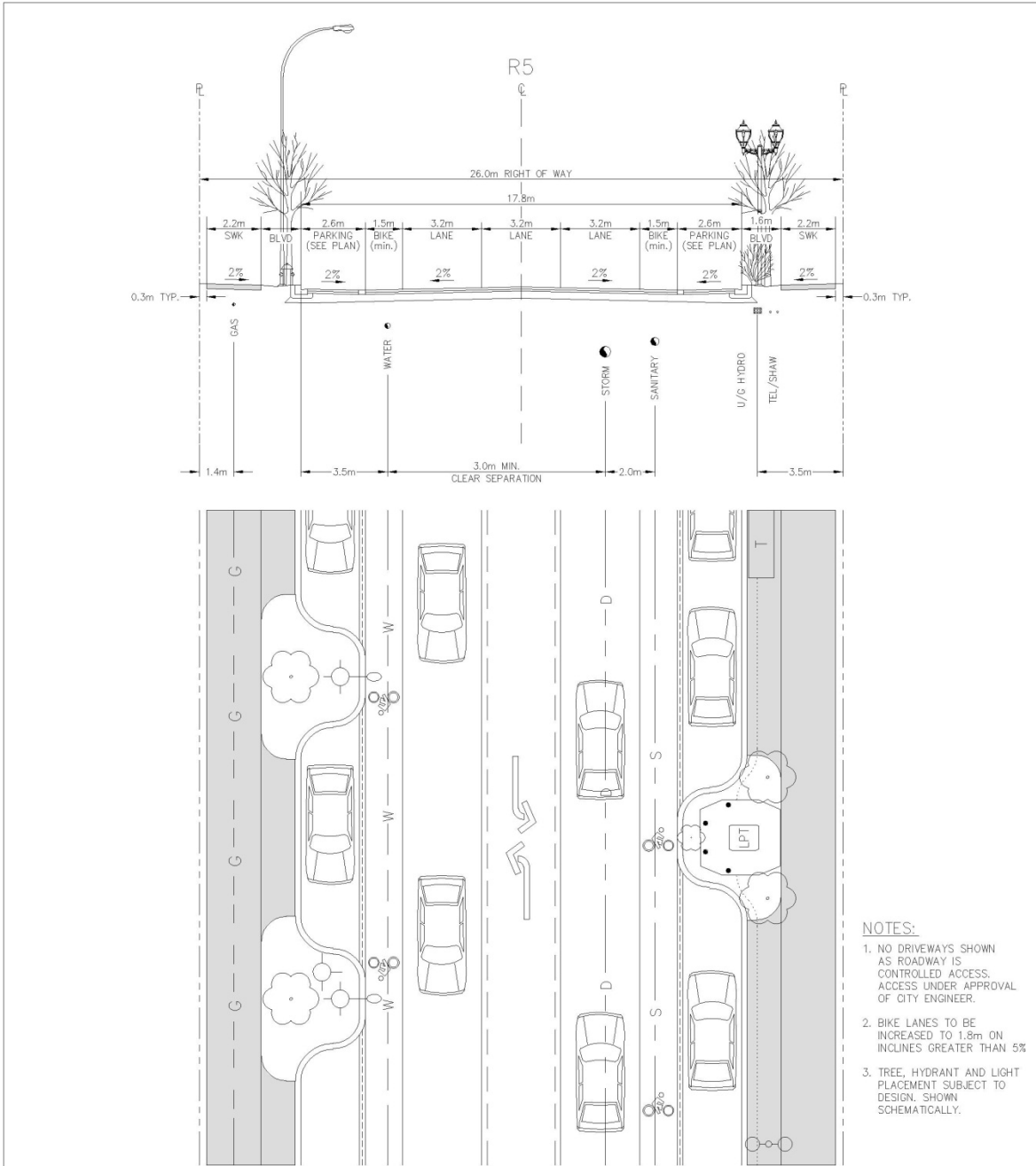

- NOTES:**
1. NO DRIVEWAYS SHOWN AS ROADWAY IS CONTROLLED ACCESS. ACCESS UNDER APPROVAL OF CITY ENGINEER.
 2. BIKE LANES TO BE INCREASED TO 1.8m ON INCLINES GREATER THAN 5%
 3. TREE, HYDRANT AND LIGHT PLACEMENT SUBJECT TO DESIGN. SHOWN SCHEMATICALLY.

<h2>URBAN COLLECTOR</h2> <h3>3 LANES - 26m ROW</h3>	 <h2>CITY OF LANGFORD</h2> <h3>ENGINEERING DEPARTMENT</h3>		DWG No. <h1>R5</h1>
	DATE: 01-Dec-10	DRAWN: TWB	
SCALE: NTS			

Last Revised: Jan 7, 2011

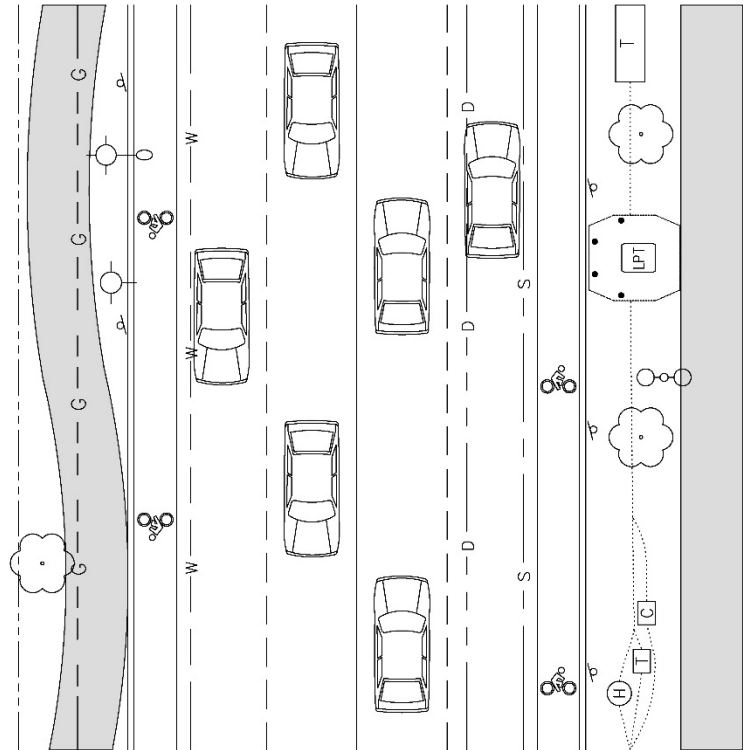
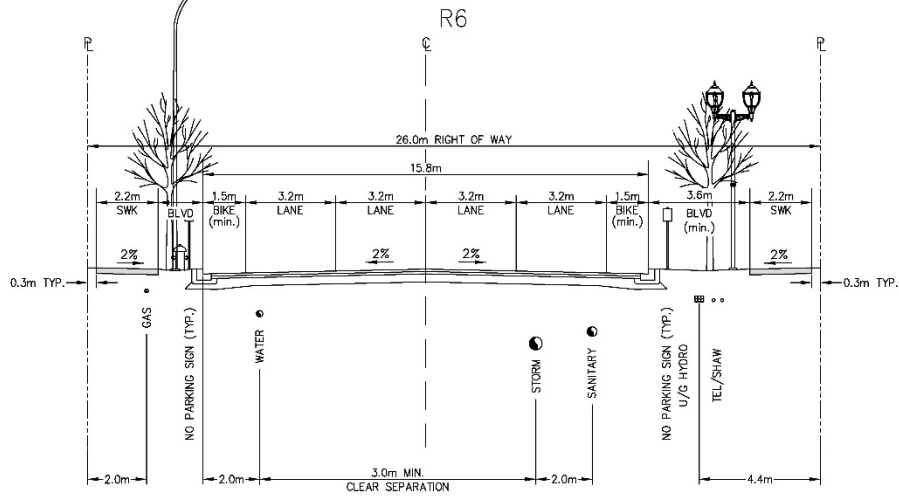

- NOTES:**
1. NO DRIVEWAYS SHOWN AS ROADWAY IS CONTROLLED ACCESS. ACCESS UNDER APPROVAL OF CITY ENGINEER.
 2. TREE, HYDRANT AND LIGHT PLACEMENT SUBJECT TO DESIGN. SHOWN SCHEMATICALLY.

**URBAN COLLECTOR
4 LANES - 26.0m ROW**



**CITY OF LANGFORD
ENGINEERING DEPARTMENT**

DATE: 01-Dec-10	DRAWN: TWB	DWG No. R6
SCALE: NTS	APPROVED: MM	

Last Revised: Bylaw 1669, February 2017

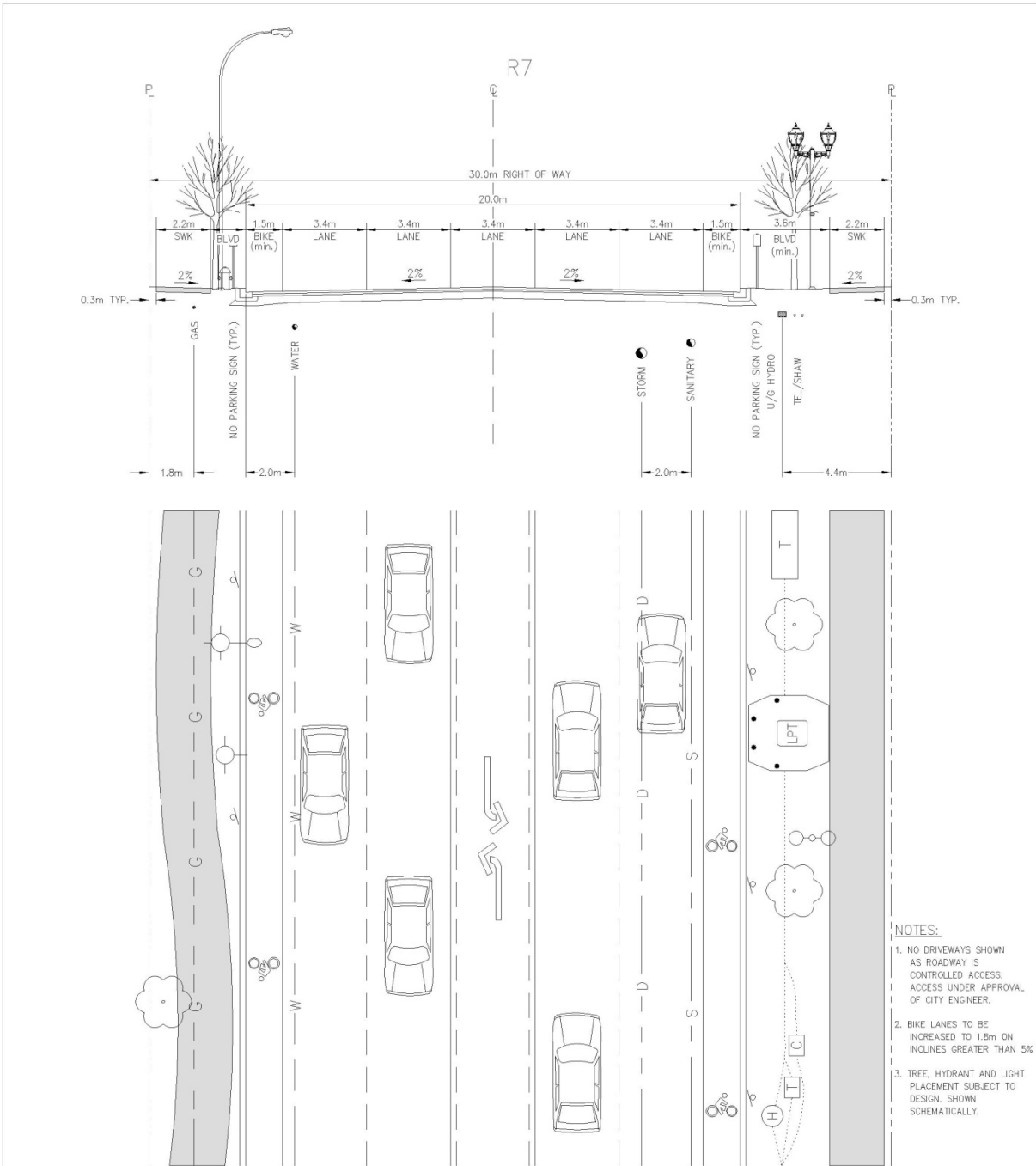

- NOTES:**
1. NO DRIVEWAYS SHOWN AS ROADWAY IS CONTROLLED ACCESS. ACCESS UNDER APPROVAL OF CITY ENGINEER.
 2. BIKE LANES TO BE INCREASED TO 1.8m ON INCLINES GREATER THAN 5%.
 3. TREE, HYDRANT AND LIGHT PLACEMENT SUBJECT TO DESIGN. SHOWN SCHEMATICALLY.

**URBAN COLLECTOR
5 LANES - 30.0m ROW**

 **CITY OF LANGFORD**
ENGINEERING DEPARTMENT

DATE: 01-Dec-10	DRAWN: TWB	DWG No. R7
SCALE: NTS	APPROVED:	

Last Revised: Jan 7, 2011

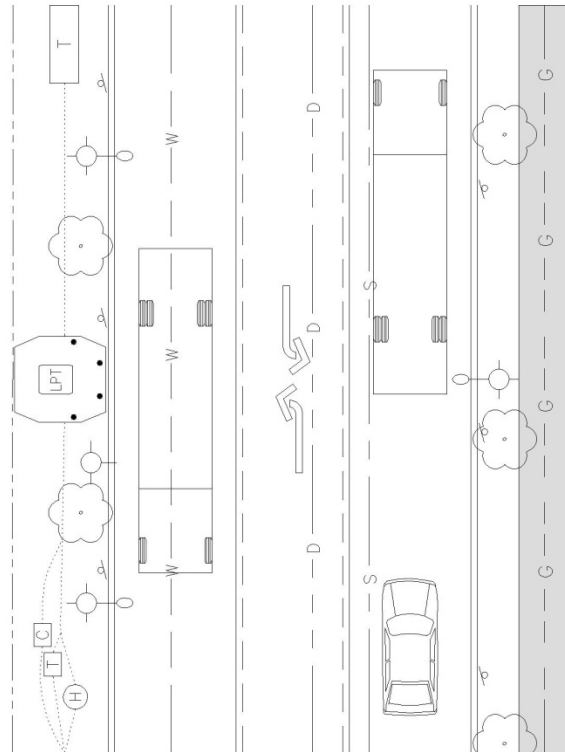
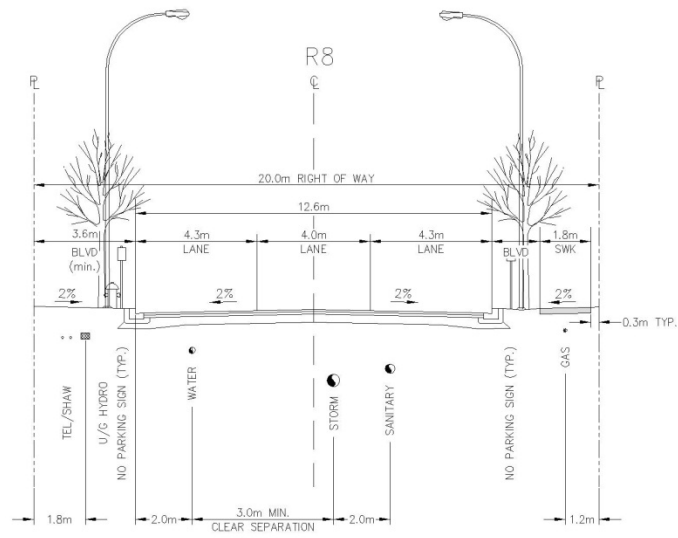

- NOTES:**
1. NO DRIVEWAYS SHOWN AS ROADWAY IS CONTROLLED ACCESS. ACCESS UNDER APPROVAL OF CITY ENGINEER.
 2. TREE, HYDRANT AND LIGHT PLACEMENT SUBJECT TO DESIGN. SHOWN SCHEMATICALLY.

INDUSTRIAL COLLECTOR
3 LANES - 20.0m ROW



CITY OF LANGFORD
ENGINEERING DEPARTMENT

DATE: 01-Dec-10

DRAWN: TWB

DWG No.

SCALE: NTS

APPROVED:

R8

Last Revised: Jan 7, 2011

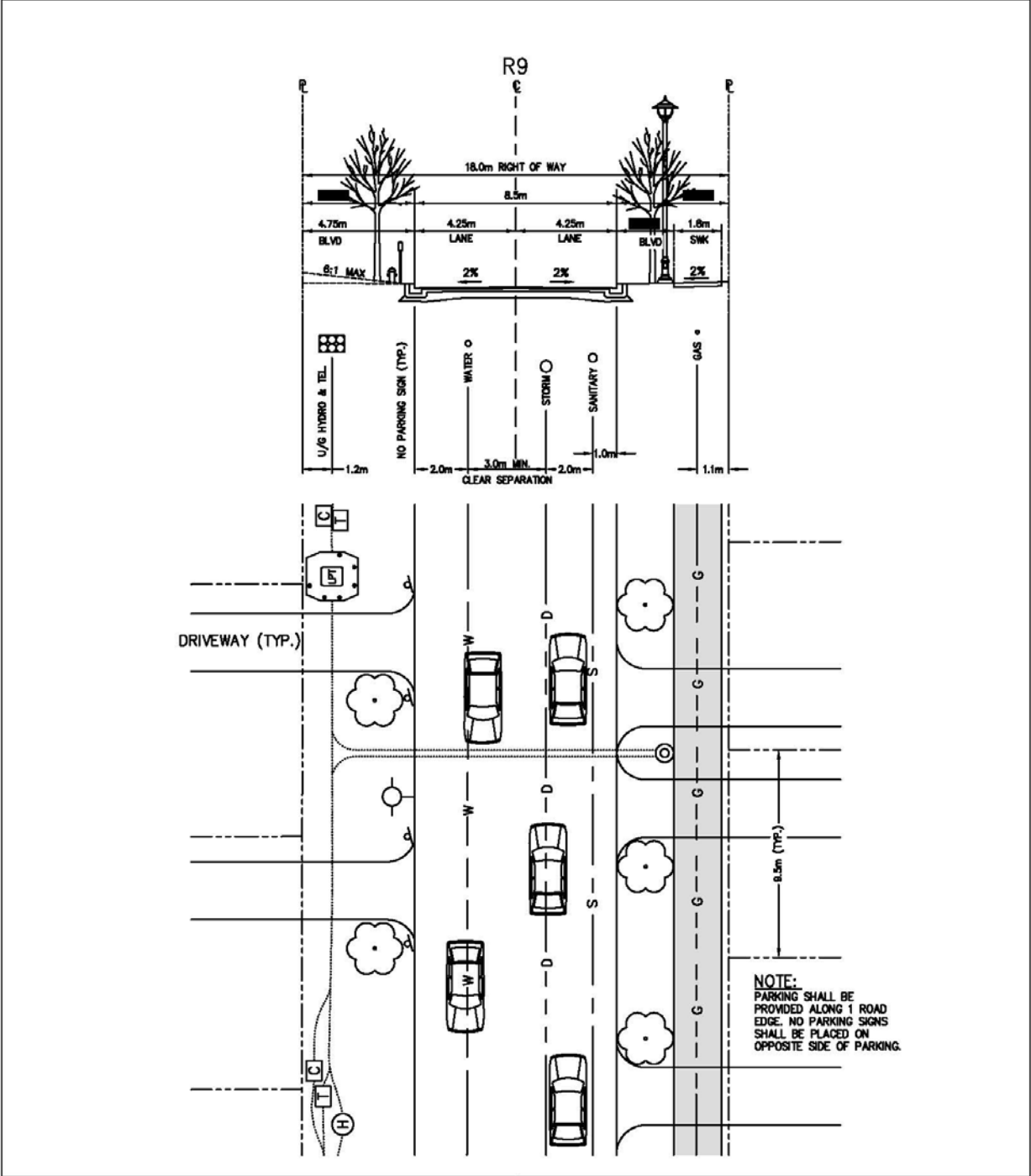

**URBAN LOCAL
2 LANES, 18m ROW**



**CITY OF LANGFORD
ENGINEERING DEPARTMENT**

DATE: 15-Sept-09

DRAWN:

DWG No.

SCALE: NTS

APPROVED:

R9

Last Revised: Oct 27, 2009

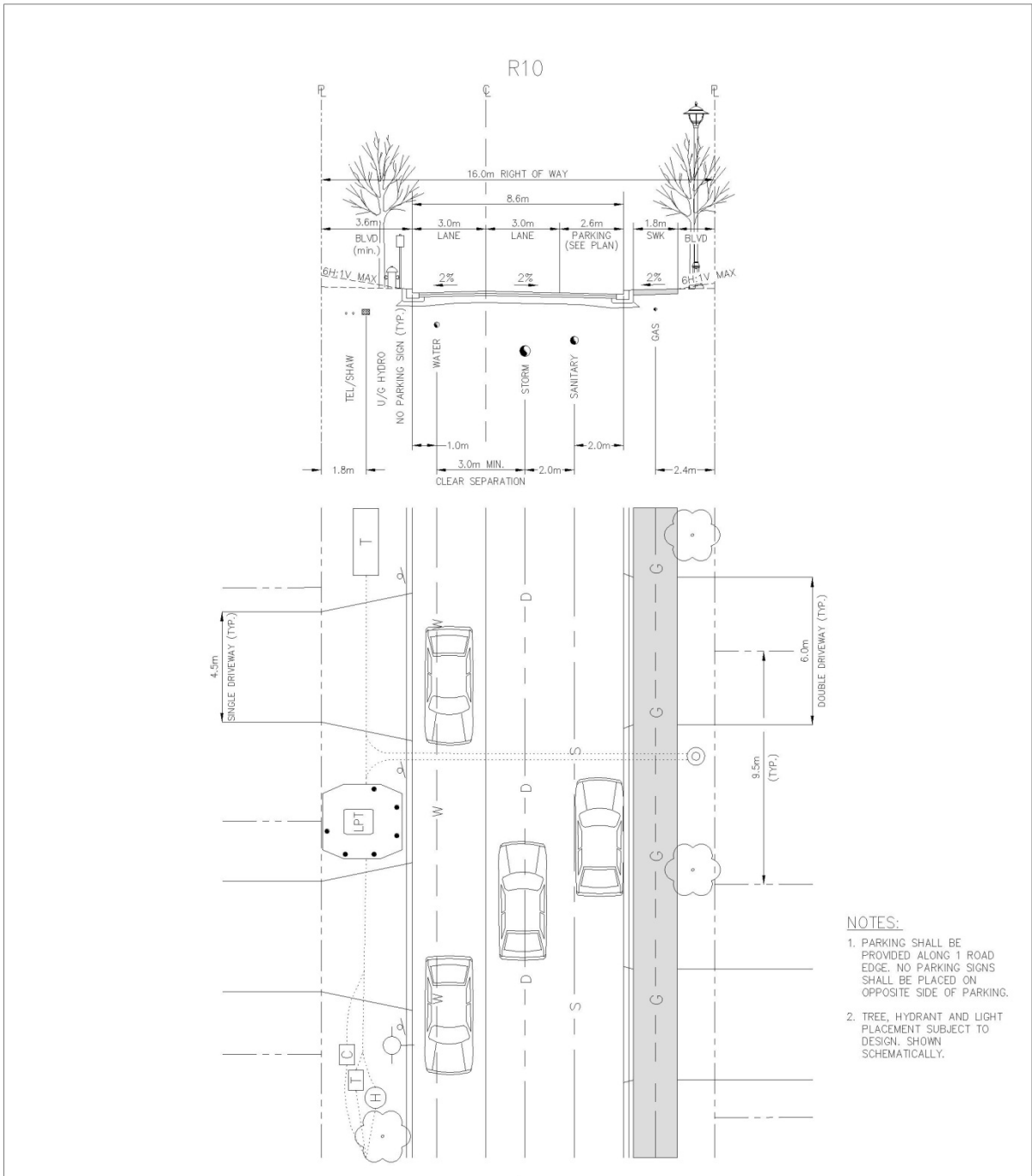

- NOTES:**
1. PARKING SHALL BE PROVIDED ALONG 1 ROAD EDGE. NO PARKING SIGNS SHALL BE PLACED ON OPPOSITE SIDE OF PARKING.
 2. TREE, HYDRANT AND LIGHT PLACEMENT SUBJECT TO DESIGN. SHOWN SCHEMATICALLY.

<h2 style="margin: 0;">URBAN LOCAL</h2> <h3 style="margin: 0;">2 LANES + PARKING, 16m ROW</h3>		<h2 style="margin: 0;">CITY OF LANGFORD</h2> <h3 style="margin: 0;">ENGINEERING DEPARTMENT</h3>	
	DATE: 01-Dec-10	DRAWN: TWB	DWG No. R10
SCALE: NTS	APPROVED:		

Last Revised: Jan 7, 2011

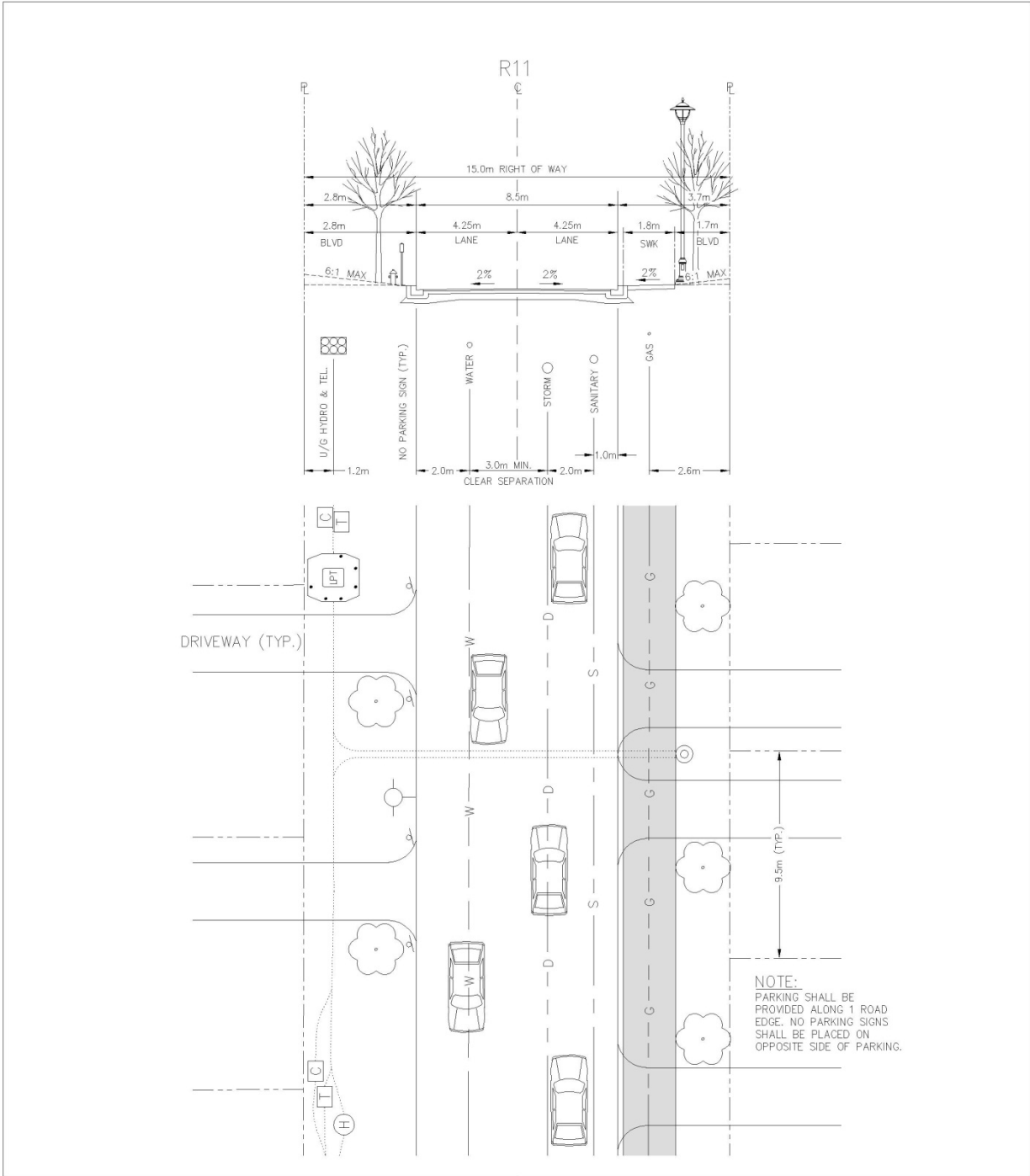

<h2>SMALL LOT</h2> <h3>15m ROW, 2 LANES - 4.25m WIDTH</h3>	 <h2>CITY OF LANGFORD</h2> <h3>ENGINEERING DEPARTMENT</h3>		
	DATE: 15-Sept-09	DRAWN:	DWG No. R11
SCALE: NTS	APPROVED:		

Last Revised: Oct 27, 2009

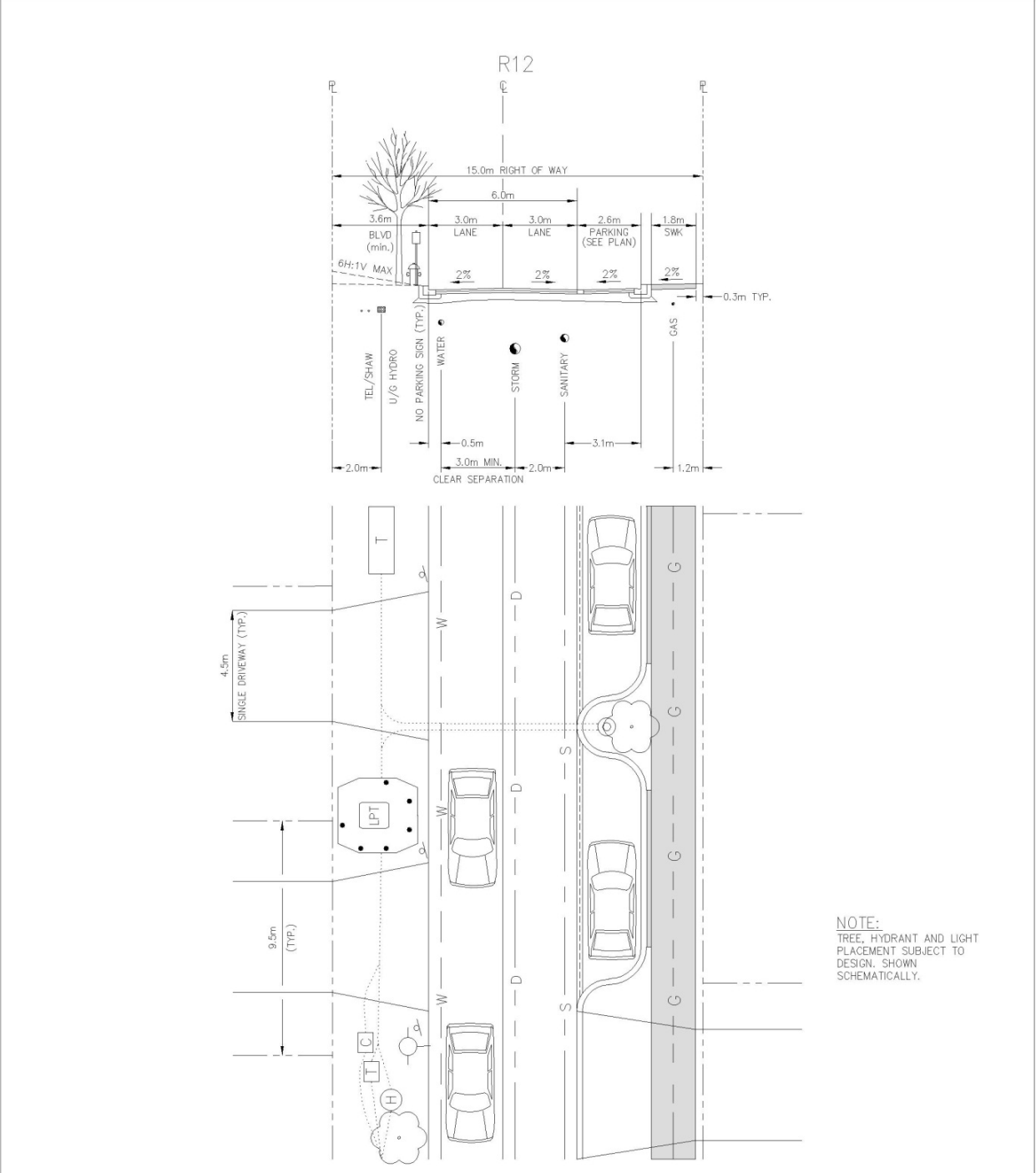

NOTE:
 TREE, HYDRANT AND LIGHT
 PLACEMENT SUBJECT TO
 DESIGN. SHOWN
 SCHEMATICALLY.

<h2 style="margin: 0;">LOCAL</h2> <h3 style="margin: 0;">2 LANES + PARKING, 15m ROW</h3>	<h2 style="margin: 0;">CITY OF LANGFORD</h2> <h3 style="margin: 0;">ENGINEERING DEPARTMENT</h3>		
	DATE: 01-Dec-10	DRAWN: TWB	DWG No.
	SCALE: NTS	APPROVED:	R12

Last Revised: Jan 7, 2011

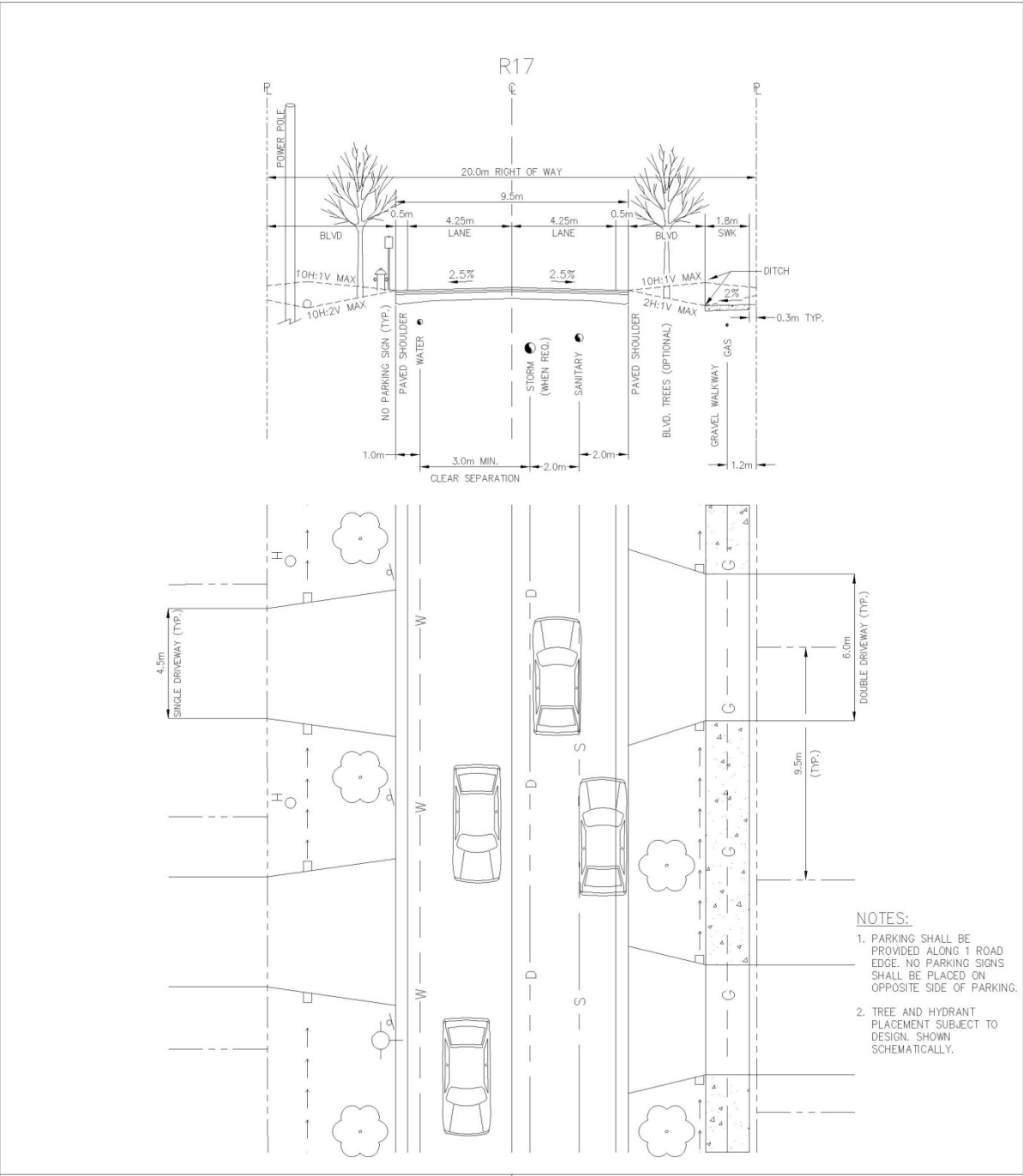

**LOCAL RURAL
2 LANES, 20m ROW**



**CITY OF LANGFORD
ENGINEERING DEPARTMENT**

DATE: 01-Dec-10

DRAWN: TWB

DWG No.

SCALE: NTS

APPROVED:

R17

Last Revised: Jan 7, 2011

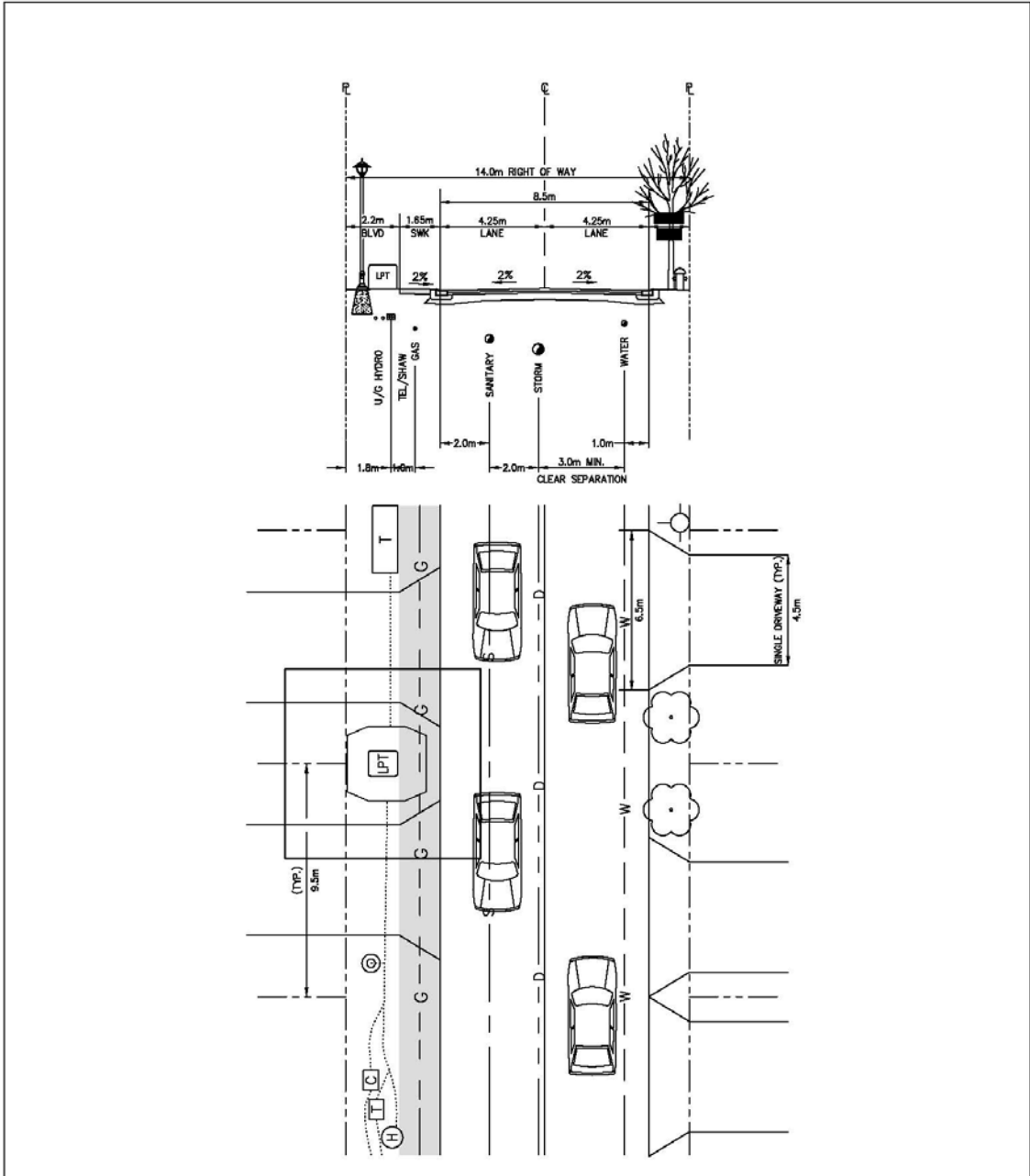

**SMALL LOT
2 LANES, 14.0m ROW**



CITY OF LANGFORD
ENGINEERING DEPARTMENT

DATE: Apr-2014

DRAWN: TWB

DWG No.

SCALE: NTS

APPROVED: MM

R18

Last Revised: Apr 7, 2014

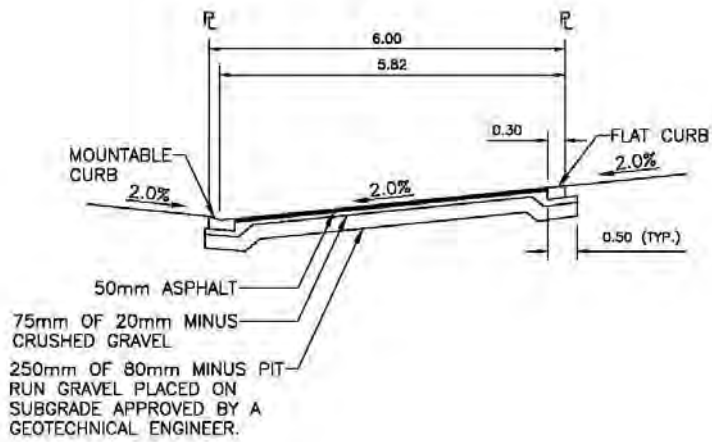

LANE SECTION



CITY OF LANGFORD
ENGINEERING DEPARTMENT

DATE: Apr-2014	DRAWN: JS	DWG No.
SCALE: NTS	APPROVED: MM	R19

Last Revised: Apr 7, 2014

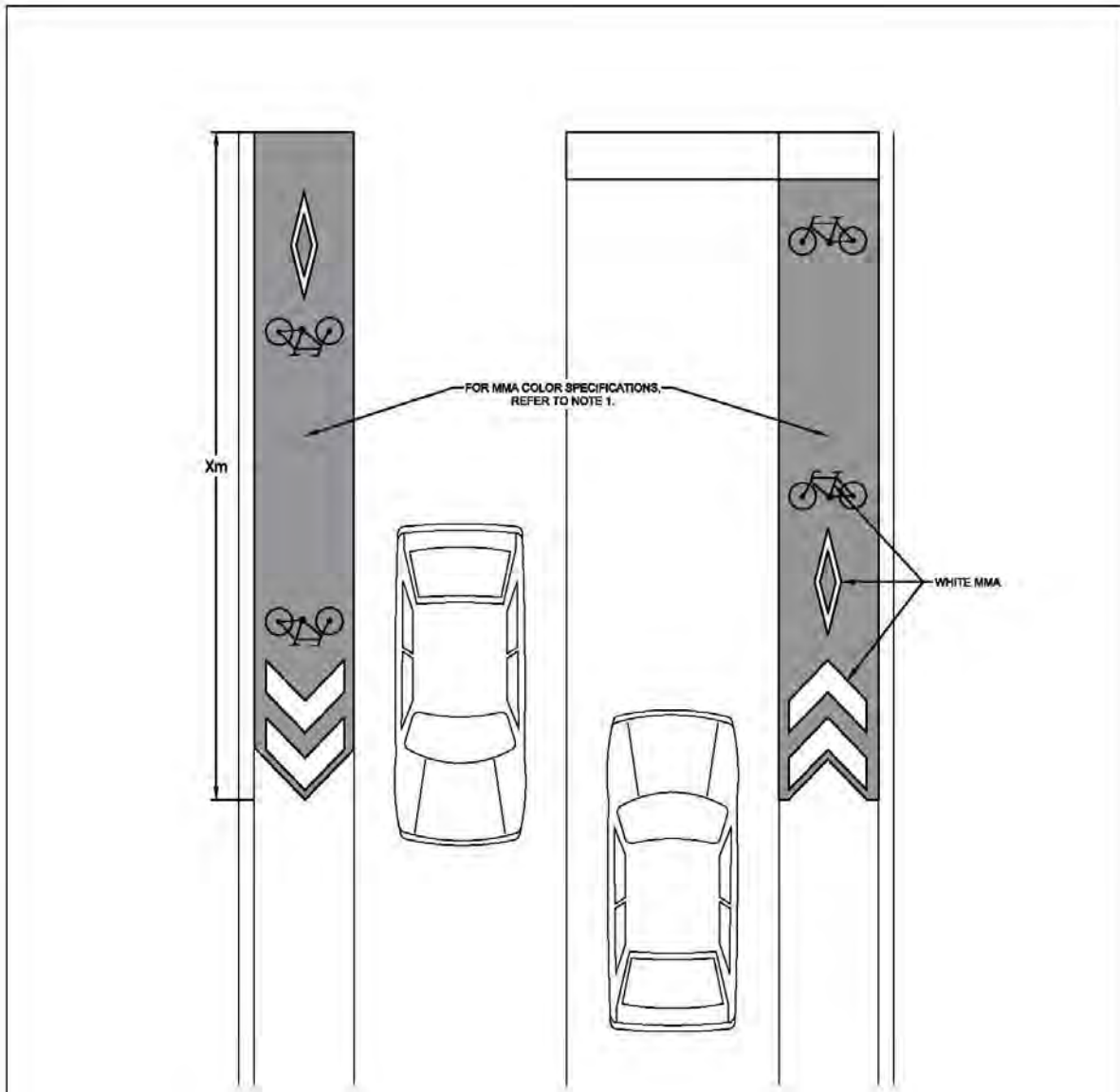

- NOTES:**
1. LAFRENTZ MMA CHROME GREEN WITH BAUXITE.
 2. X_m DETERMINED AT DRAWING APPROVAL.
 3. BPN (BRITISH PENDULUM NUMBER) MUST BE > 70 BPN.

BIKE LANE CONFLICT ZONE SPECIFICATIONS



CITY OF LANGFORD
ENGINEERING DEPARTMENT

DATE: 12-MAR-19	DRAWN: MB	DWG No.
SCALE: NTS	APPROVED: MM	R20

Last Revised: Bylaw 1817, March 2019

SCHEDULE 5 - STORM WATER MANAGEMENT

5.1. Storm Water Management General

- 5.1.1. SD-1 illustrates the major water courses within the City of Langford. Existing major storm water control and/or treatment areas are shown. These areas are to be preserved unless professional storm water management studies indicate otherwise. The areas of the municipality where storm water infiltration and storm water detention (storage) are required for development are also shown on SD-1.

The City Engineer may allow or require the use of storm water infiltration works in areas designated on SD-1 for storm water detention, if the City Engineer is of the opinion that soil conditions on the site in question are suitable for storm water infiltration, and may allow or require the use of storm water detention works in areas designated on SD-1 for storm water infiltration if the City Engineer is of the opinion that the soil conditions on the site in question are not suitable for storm water infiltration. The City Engineer's opinion shall be based on the contents of a storm water management plan for the site prepared by the Engineer or Geoscientist of Record. (Bylaw 1513)

- 5.1.2. For all subdivisions and developments in all areas of the City of Langford, drainage structures and features are required that will maintain the quality of site drainage water, minimize erosion and retain sediments.
- 5.1.3. In the infiltration areas, the sandy and gravelly soils have high infiltration potential and surface drainage conveyance structures are limited, therefore the primary means of storm water discharge will be by infiltration.
- 5.1.4. In the detention areas, storm water storage is required to control post development storm water release rates. Storm water storage may also be used in other (non-detention) areas as an alternative to upgrading downstream conveyance capacity if analysis shows capacity to be inadequate for the design flows. Except where infiltration is required and achievable, a municipal storm drain is required to serve each existing and newly created lot.
- 5.1.5. Where parkland in excess of 0.25 ha has been dedicated to the City in conjunction with the proposed subdivision or development, storm water detention and treatment facilities may be located within the park, if in the opinion of the City Engineer the treatment and detention area will not detract from the aesthetics of the park and will not affect environmentally sensitive areas within the park and the usefulness to and safety of the public.
- 5.1.6. If, in the opinion of the City Engineer, a community detention area for future developments within a specific storm drainage catchment area would be preferable to permanent on site storage facilities, then permanent storage and treatment areas on site may not be required. The developer shall provide land dedication or cash in lieu of this community detention area (by DCC or otherwise) and shall provide temporary facilities and the infrastructure to direct storm water to those future detention areas in

accordance with this bylaw. Any lands required for the temporary facilities shall have a right-of-way in favour of the City of Langford for storm drainage which may expire when the community detention area is constructed.

- 5.1.7. A storm water management plan prepared by a Professional Engineer is required which will show: (Bylaw No. 1669)
 - 5.1.7.1 Scaled topographic site plan with existing cadastral and proposed development layout.
 - 5.1.7.2 Drainage catchment areas showing contributory area to the site, onsite subcatchments, cumulative catchments and points of discharge.
 - 5.1.7.3 Predevelopment and post development flows.
 - 5.1.7.4 Internal drainage structures for conveyance, control and treatment.
 - 5.1.7.5 Existing and proposed offsite works.
 - 5.1.7.6 Erosion and sediment control works.
- 5.1.8. Within the areas where storm water detention is required, the Professional Engineer shall certify that for all events up to the estimated 200 year runoff event there will be no increase in water levels or rates of erosion at any point in the watershed as a result of the development compared to original site conditions, before the removal of natural vegetation.

5.2. Flood Plain Elevation Criteria

- 5.2.1. All structures intended for occupancy shall be designed with the underside of the floor system situated 600 mm (1000 mm adjacent to Millstream Creek, between the Trans Canada Highway and Treanor Ave.) above the 200 year peak flood elevation. (Reference: City of Langford Official Community Plan, Map 16, 200 Year Flood Plain.) Where adjacent flood elevations are not available the hydraulic profile shall be extended through hydraulic analysis to the development site, except where the site is clearly above the estimated flood elevations. All habitable structures shall also be protected from flooding by grading drainage away from the structure and providing overland flow routes through the site that are capable of safely conveying the 200 year runoff event. These routes, if not on roadways, shall be maintained in perpetuity and protected with rights of way in favour of the City.

5.3. Storm Drainage Systems Design Criteria

- 5.3.1. All minor systems, those designed and installed as part of the works and services for the subdivision or development, shall be designed for a 10 year peak flow rate. The site must allow for 200mm of ponding onsite to be directed to an overflow route either piped or overland.

- 5.3.2. All minor systems associated with a commercial, industrial, multi family or institutional development as described by City of Langford Zoning Bylaw shall be designed for the 1:25 year storm.
- 5.3.3. Previously undeveloped areas must create an overland route within the subdivision or development for the 1:200 year rainfall event to allow for the failure of the drainage system. This route must be physically protected and have a right-of-way in favour of the City.
- 5.3.4. Where, in the opinion of the City Engineer, future development or subdivision shown in the Official Community Plan for the City is probable for the lands adjacent to the development or subdivision, storm sewers must be extended to the property boundary and terminated with a cleanout or a manhole. A right-of-way in favour of the City must be provided for this storm sewer on private property for access and maintenance.
- 5.3.5. Storm drainage conveyance or disposal systems are required in the road right of way adjacent to the subdivision or development for all new and existing highways.
- 5.3.6. If a vertical seepage pit is installed for in ground storm water disposal for the 1:25 year storm, the developer is not required to treat storm water with a oil separation device prior to disposal unless the disposal system is constructed in conjunction with required improvements for an auto repair or service facility, gas stations, or property zoned for industrial uses. Vertical seepage pits shall be designed in accordance with SD-7.

5.4. Tributary Area Schematic

- 5.4.1. Runoff calculation for subdivisions and development of Small Sites may be by the Rational Method. Analysis of upland and downstream catchments, up to a maximum of 10 ha, may also be calculated with the Rational Method. Calculations shall be submitted in tabular form in accordance with *SD-2* and certified by a Professional Engineer. For larger catchments reference shall be made to the Storm water Management Plan for pre-calculated values. The values shall be verified by the City prior to use by the developer's engineer. Original calculations for Large Sites and areas exceeding 10 ha shall be performed with a hydrograph method. Design parameters shall reflect BC west coast conditions.
- 5.4.2. If in the opinion of the City Engineer conditions warrant, a tributary area plan shall accompany the runoff calculation and include:
 - 5.4.2.1 Scaled topographic site plan with existing cadastral and proposed development layout.
 - 5.4.2.2 Drainage catchment areas showing contributory areas to the site, on-site subcatchments for each inlet, manhole and outlet.
 - 5.4.2.3 Locations of other drainage structures including silt traps, oil grit separators, and storage chambers.

- 5.4.2.4 Provision shall be made for servicing lands beyond (upstream) from the site by providing a point of access on a right of way and adequate conveyance capacity within the subdivision or development.
- 5.4.3 Rainfall intensity shall be taken from the intensity-duration-frequency (IDF) curves provided in *SD-3*. The minimum initial time of concentration shall be 10 minutes. For catchments which will remain undeveloped, the time of concentration shall be calculated using good engineering judgement.
- 5.4.4 Where soils will be exposed by land clearing, measures shall be taken to minimize potential erosion following the concepts illustrated in *SD-4*, including:
 - 5.4.4.1 Scheduling works for the period April through October inclusive, to the extent practical.
 - 5.4.4.2 Clearing the minimum possible land area.
 - 5.4.4.3 Clearing immediately before construction commences.
 - 5.4.4.4 Restricting vehicle access and providing a surfaced working area.
 - 5.4.4.5 Suspending construction activities during rainy periods and when soils are saturated.
- 5.4.5 All disturbed surfaces shall be protected against the loss of soils through the use of silt fencing as shown in *SD-5* to be located wherever surface drainage will leave the site as overland flow. Watercourses and ditches shall be protected by placing the silt fencing along the bank of the channel. Bare areas subject to erosion shall be covered by hand placed straw mulch.
- 5.4.6 Where disturbed catchment areas exceed 0.20 ha, a sediment basin as described in *SD-6*, shall be constructed. This requirement may be waived in rocky areas or if construction is completed in the April to October period and finished with a non-erodible surface. Erosion and sediment control measures shall be constructed before clearing and earthworks commence and remain in place until at least 80% of all building construction and landscaping are complete. Sediment traps may be converted to constructed wetlands at this time. Sediment traps shall be clear of sediments on September 30 each year and re-excavated any time the available storage has been reduced by one-third of the original volume.
- 5.4.7 Despite the requirements of this section it shall be the responsibility of the professional engineer to specify appropriate measures and ensure that sediment-laden water and any other deleterious substances do not leave the site or reach aquatic habitat areas.

5.5 Pipe Main Parameters

5.5.1 Specifications

Roughness coefficients	Concrete 0.013, PVC 0.013
Minimum diameter	300 mm
Minimum velocity	0.61 m/sec (flowing full or half full)
Maximum velocity	6.1 m/sec

Above this maximum velocity, special consideration must be given by the Professional Engineer to incorporate pipe materials and construction methods, including pipe anchorage, scour protection and energy dissipation to the satisfaction of the City Engineer.

The choice of pipe material shall be in accordance with the current edition of MMCD. No corrugated metal pipe (CMP) or corrugated steel pipe (CSP) is permitted. (Bylaw Nos. 1669, 1817)

- 5.5.2 Pipes may be laid to the minimum vertical and/or horizontal radius of 60 metres or as recommended by the manufacturer, providing the design velocity (full pipe) is increased to 0.914 m/s for the curved section.
- 5.5.3 Mains shall have at least 1.0m cover and be deep enough to provide drainage to 0.6m below the existing or proposed basement floor elevation of each property being serviced based on a 2.0% grade from the main overt.
- 5.5.4 When a stormwater pipe is installed such that it crosses below an existing asbestos cement (alc) watermain, the existing watermain material shall be replaced with ductile iron pipe for a distance of at least two (2) metres beyond each edge of the trench of the service crossing the watermain.

5.6 Manholes

- 5.6.1 Manhole structures shall be in accordance with MMCD S1 and S2.
- 5.6.2 Manholes shall be provided at all changes in grade, pipe size, horizontal alignment (for non-curvilinear sewers) and at the upper end of mains not to be extended in the future. Only one curve, horizontal and/or vertical, is permitted between manholes. In addition to the foregoing, additional manholes shall be constructed so that the maximum distance between manholes is as follows:

Pipe size (mm Ø)	Maximum Distance (m)
375 and smaller	125
450 and 750	155
900 and larger	185

- 5.6.3 Cleanout structures may be used at the upper terminus where the main will not be extended and the end of the present construction is within 45m of an existing manhole. Cleanout structures shall be constructed in accordance with drawing SS-S6.
- 5.6.4 Outside drop manholes will be permitted, if in the opinion of the City Engineer, the circumstances preclude the use of normal manholes. These shall be constructed wherever the change in invert elevations through the manhole are greater than 600mm. Elevations changes greater than 600mm shall be by way of an outside drop only. Allowance shall be made in the design for the effect of the resulting turbulence on the hydraulic capacity of the system.
- 5.6.5 The relative elevations entering and leaving a manhole must not reduce the hydraulic capacity of the system.
- 5.6.6 Allowances for energy losses or changes in velocity are to be determined in accordance with sound hydraulic principals.
- 5.6.7 The City Engineer may approve situations involving a large pipe flowing into a smaller pipe at steeper grade.
- 5.6.8 Stubs shall be placed in manholes to allow for future connections. The length of the stubs shall be 600mm maximum from the outside of the manhole. The end shall be securely capped to the satisfaction of the City Engineer. Grades shall be suitable for future extension of the system.
- 5.6.9 Manhole benching shall be a steel trowel finish with a constant grade from the inlet(s) to the outlet. The benching inside radius shall be no less than three times the branch diameter. Pre-benched manholes are permitted.
- 5.6.10 All channels shall be constructed to permit use of a pan and tilt camera having dimensions of 600mm x 150mm diameter.
- 5.6.11 The obvert of pipes entering a manhole shall not be lower than 50mm above the obvert of the outlet pipe. The internal channel in the manhole shall have an elevation difference of 5% from the inlet to the outlet.
- 5.6.12 Manhole and cleanout lids are to be set to match existing or planned grades both longitudinally and transversely. If the highway grade is greater than 6%, manhole castings shall be encased in a concrete surround poured to 150mm below the rim.
- 5.6.13 All manhole barrel and sections shall be installed with rubber gaskets and mastic and shall be grouted inside with rapid set non-shrink grout. If, in the opinion of the City Engineer the water table may be high enough to affect the manhole, fibreglass bases in a concrete liner may be required.
- 5.6.14 Inlet and outlet pipes shall be grouted inside the manhole with rapid set non-shrink grout.

- 5.6.15 All manhole lids and cleanouts must be cast to include “Lanford Storm”. (Bylaw No. 1817)

5.7 Service Connections

- 5.7.1 Storm sewer service connections of adequate size, but not less than 100mm Ø shall be provided from a main to the property line of each new or existing parcel, which forms part of the development or which fronts a highway or other right-of-way in which the sewer is to be constructed and shall be constructed in accordance with MMCD S8. (Bylaw No. 1817)
- 5.7.2 All service connections shall be provided with an inspection chamber at the property line or at service the right-of-way boundary in accordance with drawing SS-S9.
- 5.7.3 All service connections shall terminate a distance inside the property line equal to the depth at the property line for new parcels unless otherwise approved by the City Engineer and at property line for existing parcels at a location agreed upon by the owner. All stubs must have a 1% minimum gradient from the inspection chamber into private property in accordance with the Building Code and 2% minimum from the sewer main to the inspection chamber, in accordance with the MMCD Documents.
- 5.7.4 Where deep sewers exist, the service stub shall be terminated within 1.0 vertical meters of the minimum basement floor elevation and marked with a 2x4 stake. The service connection shall have a long radius sweep and be installed at no more than 45 degrees from the vertical.
- 5.7.5 Deleted by Bylaw No. 2103.
- 5.7.6 Wherever possible, adjoining lots shall be serviced with one 150mm^Ø service connection with one 100mm^Ø stub and one inspection chamber for each lot, or may terminate at a 150x100x100 duplex inspection chamber.
- 5.7.7 All service connection locations shall be located with a 40mm x 90mm stake painted green complete with a green insulated wire from a nail on the stake to the service connection cap and the depth to invert marked.

5.8 Inspection Chambers

- 5.8.1 All inspection chamber (IC) lids and collars shall be installed in accordance with drawing SS S9. The lid cams shall be securely tightened to ensure that they are not subject to vandalism or misuse. (Bylaw No. 1494)
- 5.8.2 All inspection chambers shall have a cast iron chamber cover and concrete surround in accordance with drawing SS S9.
- 5.8.3 Any inspection chamber set in a slope greater than 3% shall have a cast iron chamber cover and concrete surround in accordance with SS S9.

- 5.8.4 Wherever a inspection chamber is covered by a cast iron chamber cover, the clearance between the cast iron lid and the plastic lid shall be a minimum of 75mm.
- 5.8.5 Inspection chambers shall be supplied and installed without plugs.
- 5.8.6 The inspection chamber lid shall be fastened to the riser pipe with a stainless steel machine bolt as provided by the manufacturer.
- 5.8.7 Where property line is within 1 meter of the backside of a sidewalk or curb the inspection chamber shall be installed using cast iron inspection chamber cover specified in drawing SS S9, in a cast in place concrete apron protruding from the sidewalk or curb toward the property. This apron shall be constructed to the same engineering specifications as the sidewalk and shall provide a minimum of 200mm of concrete from the edge of the cast iron lid to the edge of the apron. An expansion joint at the sidewalk or curb to apron interface shall be provided.
- 5.8.8 Inspection chambers shall be a minimum of one meter apart from centre to centre when installed, unless, in the opinion of the City Engineer the clustering of services would be beneficial to site servicing and layout, in which case the sewer and drain connections may be installed on one adjoining property line.

5.9 Testing

- 5.9.1 CCTV videos and reports are to be accompanied with half size drawings. CCTV videos required prior to hot-mix asphalt concrete.
- 5.9.2 If in the opinion of the City Engineer conditions warrant, the storm drainage system must be flushed and re-videoed prior to the 1 year warranty inspection.
- 5.9.3 Minimum quality control test frequencies specified are the minimum number required to determine sufficient trench compaction. The contractor shall perform as many tests as are necessary to ensure that the works and services conform to the requirements of the contract regardless of the minimum number required as follows:
 - 5.9.3.1 Trench bedding (mainline) – one test for every 75m of trench. Minimum one between any two manholes.
 - 5.9.3.2 Trench backfill (mainline) – one test for every 75m of trench at each 1.0m fill depth. Minimum one between any two manholes.
 - 5.9.3.3 Trench bedding (service) – one per service lateral under a paved surface.
 - 5.9.3.4 Trench backfill (service) – one per road crossing at each 1.0m fill depth.
 - 5.9.3.5 Roadbase – one per road crossing.
 - 5.9.3.6 Roadbase – one for every 75m of trench with a minimum of one between any two manholes.

5.10 Catch Basins

5.10.1 Catch basins are detailed as per drawing SS S11 shall be provided as required to collect from a maximum area of 400 square metres of road, at the beginning of curb returns to which water flows and at low points. Leads will be a minimum 150 mm diameter. Rim elevations shall be 25 mm below finished pavement grade. (Bylaw No. 1817)

5.10.2 The catch basin grate must be a $\frac{3}{4}$ grate. (Bylaw No. 1817)

5.11 Inlet Structures

5.11.1 Storm sewer inlet structures shall be provided when the following conditions are encountered:

5.11.1.1 Type I inlet (MMCD drawing No. S13) used where a ditch carries storm water into the storm system of the proposed subdivision or development.

5.11.1.2 Lawn basin (MMCD drawing No. S12) in local low spots where storm water is unable to reach the storm system by a ditch.

5.11.2 Headwalls other than those described in Sections 5.11.1.1 and 5.11.1.2 must be mortared rock or precast concrete. Sandbag inlet headwalls are permitted for repairs to existing sandbag headwalls only. (Bylaw No. 1669)

5.12 Outfall Structures

5.12.1 Inlet and outlet structures shall be mortared rock or precast concrete unless otherwise approved by the City Engineer.

5.12.2 Cast in place reinforced concrete outfall structures shall be provided at all watercourses. In all cases energy dissipation shall be provided to reduce maximum outlet flow velocity to 1.0 m/s.

5.13 Treatment Options

5.13.1 Stormwater detention (storage) may be combined with a constructed wetland or oil/grit separator chamber or provided in a separate detention facility such as a pond or underground chamber. The 2-year event shall be controlled to prevent watercourse and aquatic habitat impacts. The 10-year event shall be controlled to protect downstream conveyance capacity. The required live storage volumes and corresponding release rates are tabulated below. Where both 2-year and 10-year control is required, the combined storage requirement is also provided. See table below:

Site Soils		2-year	10-year	2- and 10-year combined
Rocky <500 mm of soil	Live storage (m ³ /ha catchment without native vegetation)	100	120	180
	Controlled release rate (L/s/ha total catchment)	10	20	10 and 20
Soils >500 mm of silts and clays	Live storage (m ³ /ha catchment without native vegetation)	110	135	200
	Controlled release rate (L/s/ha total catchment)	8	16	8 and 16
Soils >500 mm of sands and gravels	Live storage (m ³ /ha catchment without native vegetation)	125	150	225
	Controlled release rate (L/s/ha total catchment)	5	10	5 and 10

5.13.1.1 Proprietary systems including enhanced manholes, swirl concentrators and deflection screen technologies may be used providing the Professional Engineer can clearly demonstrate that the proposed system will treat storm water to the same criteria as 5.13.3 and the proposed system is certified for performance by the Professional Engineer for the specific site.

5.13.1.2 Infiltration systems shall incorporate appropriate pre-treatment systems (for example an oil/grit separator) to protect contamination of the disposal area.

5.13.2 Where in-ground disposal is permitted, vertical seepage pits shall be provided and installed in accordance with drawing SD-7. Seepage pits shall be protected by a catch basin.

5.13.3 Drainage water quality improvements for all subdivisions and land developments shall be achieved preferably with a constructed wetland as shown in SD-8 and to the satisfaction of the City Engineer. With outlet control and sufficient live storage, the wetland may also serve as a detention pond. The permanent water surface area (as defined by the outlet culvert invert) shall be a minimum of 1% of the contributory catchment area. The constructed wetland shall have a normal outlet capacity for the peak 10 year design flow and an emergency overflow capacity for the 200 year peak design flow that is routed in such a way that it does not flood downstream property or subject it to erosion. Constructed wetlands should have maintenance vehicle access.

Where constructed wetlands are not used, proprietary systems with filtration media may be approved if certified performance and a specification for the site are submitted for approval by the City Engineer.

For Small Sites, or small catchments within Large Sites that cannot be directed to a constructed wetland, the following alternative storm water treatment techniques may

be used:

SD-9	Grass Swale
SD-10	Filter Strip
SD-11	Oil/Grit Separator Chamber with External High Flow Bypass
SD-12	Oil/Grit Separator - Type 1
SD-13	Oil/Grit Separator - Type 2
	Permeable Pavement, in accordance with product specifications

These treatment facilities shall be designed on the basis of the post development peak "6-month" event which is deemed to be 60% of the 2-year peak flow. Oil/grit separator chambers may be proprietary or non-proprietary. Design criteria for non-proprietary separators are included on the standard drawings. These concepts are expected to remove approximately 90% of the sediment particles larger than 100 microns (0.1 mm).

5.13.4 For these subdivisions and developments, the designer is encouraged to use combinations of engineered wetlands and ponds to conform to the water quality and runoff rate requirements.

5.13.5 The following facilities may be used alone or in combination to achieve the desired detention and treatment.

5.13.5.1 SD-14 shows a typical flow control manhole for use at stormwater detention facilities where only the two year event is being controlled.

5.13.5.2 SD-15 shows a combined detention and oil/grit separator.

5.13.5.3 SD-16 illustrates a detention facility that will serve a 0.5 to 1.0 ha site that will have no remaining native vegetation and is rocky with 15% slopes and must provide detention for both the 2 year (watercourse protection) and 10 year (storm drain capacity protection) events.

5.13.6 Stormwater storage volumes may be reduced if used in combination with an infiltration system designed in accordance with good engineering practice. The reduction in the storage requirement shall be proportional to the percentage of peak 2 year event post development discharge that is infiltrated to ground. Stormwater storage may be eliminated if the peak 2 year event post development discharge downstream from an infiltration system does not exceed the release rate tabulated above.

5.14 Storm Water Management Guideline

5.14.1 An applicant for subdivision or building permit may be required to submit a storm water management report by a professional engineer. The report must make reference to Land Development Guidelines for the Protection of Aquatic Habitat and Stream Stewardship: A Guide for Planners and Developers, available from BC Environment, and must indicate how the development conforms to those guidelines. The engineer

designing this system may have the proposal assessed with the City of Langford's watershed computer model. (Bylaw No. 1669)

- 5.14.2 The following statement by the design engineer for the stormwater management system is required in the report as described above in Section 5.14.1: (Bylaw No. 1669)

"I confirm that the Storm Water works and services have been designed in accordance with the Subdivision and Development Servicing Bylaw No. 1000 (and as amended from time to time), and to meet normal standards of safety for the public and the occupant of the land and surroundings.

To the best of my knowledge, no nuisance or increase in flood levels are expected resulting from the project for the design storm events in the bylaw. Overland flow routes for the major event have been accommodated in the design." (Bylaw No. 1669)

- 5.14.3 In the case of works to be maintained by private entities, an Operations and Maintenance Manual to be provided.

5.14.4 Delete. (Bylaw No. 1669)

5.14.5 Delete. (Bylaw No. 1669)

- 5.14.6 Where ever possible, storm water from private commercial/industrial property is to be disposed of on that property and storm water from public road is to be disposed of in the road right-of-way. Storm water run-off from roofs or paved areas shall be passed through a water purification device or pond which in the opinion of the City Engineer removes impurities in the water to the same degree as a StormCeptor™.

SCHEDULE 6 SEWAGE COLLECTION AND DISPOSAL

6.0 SEWAGE COLLECTION AND DISPOSAL

6.1 General

6.1.1 New subdivisions and development may only be created and occur when serviced by the municipal sanitary sewer system.

6.1.1.1 Notwithstanding s.6.1.1., development without being serviced by the municipal sanitary sewer system may occur in areas outside the West Shore Environmental Services contract area for sewer service [defined in the agreement dated September 20th, 2004 (West Shore Utility; Bylaw No. 876)], under one or more of the following circumstances:

- a) Each parcel is a minimum of 40ha in area and has a sufficient area for sewage disposal to comply with the Sewerage System Regulation under the *Public Health Act*, or has the benefit of an easement for access to such an area for sewage disposal on another parcel that is a minimum of 40ha in area.
- b) Construction of a building on a lot that has been vacant since September 20th, 2004 (the date of adoption of the West Shore Utility; Bylaw No. 876).
- c) Construction of an accessory building.
- d) Construction of a building that *replaces, alters, or increases the floor area of* an existing building.

6.1.2 In areas *not* served by the municipal sewer, but contained within the West Shore Environmental Services contract area for sewer service [defined in the agreement dated September 20th, 2004 (Westshore Utility; Bylaw No. 876)], development (except for any form of subdivision other than a strata subdivision of a two-family dwelling) may occur without connection to the municipal sanitary sewer system provided the following conditions have been met: (Bylaw 1513)

- a) The owner grants to the City a covenant under s.219 of the *Land Title Act* that requires the owner to connect the building to the municipal sanitary sewer system within 6 months of a sewer main being installed in a highway or City statutory right of way abutting the parcel on which the building is located.
- b) Payment of the Sewer Capital Recovery Fee (SCRF) to West Shore Environmental Services or the City of Langford is made prior to the issuance of a building permit authorizing the construction of the building.
- c) Installation of all on-site plumbing necessary between the building and a point 1.0 m from the boundary of the highway or statutory right of way that the City designates as the future location of the sewer, to allow the building to be connected to the municipal sanitary sewer system in accordance with the *BC Building Code*, and the works are installed in accordance with the permit prior to occupancy of the building. The City may require the owner to install works for either a 100mm diameter gravity connection or a 50mm diameter force main connection.

Figure 6.1

Removed by (Bylaw No. 1513)

6.1.2.1 Notwithstanding Section 6.1.2, in areas not served by the municipal sewer, but contained within the West Sore Environmental Services contract area for sewer service [identified in the agreement dated September 20th, 2004 (Westshore Utility; Bylaw No. 876)], the following forms of development may occur without connection to the municipal sanitary sewer system: (Bylaw No. 1494)

- i. The alteration or repair of a residential building; or
- ii. The construction, alteration, or repair of a building that is accessory to a residential building;

Provided that all of the following conditions are met:

- a) The construction, alteration or repair is pursuant to a building permit or is exempt from the requirement of a building permit; and
- b) The construction, alteration or repair is not for the purpose of creating an additional dwelling unit or units except where the additional dwelling unit is a permitted secondary suite within a principal dwelling; and
- c) The construction or alteration does not create more than 70m² (750ft²) of new gross floor area, or a cumulative total of more than 70m² (750ft²) of new gross floor area when considered together with all alterations
(Bylaw 1513)

6.1.3 Wherever, in the opinion of the City Engineer, future development or subdivision shown in the Official Community Plan for the City is probable for the lands adjacent to the development or subdivision, sanitary sewers must be extended to the property boundary and terminated with a capped stub or a manhole. Size and location shall be suitable for the future extension to the satisfaction of the City Engineer.

6.1.4 Each parcel in a subdivision which is not connected to the municipal sewer system shall have an area for sewage disposal approved by the Capital Health Region Environmental Health Officer or shall have secure access to such an approved area for sewage disposal on another parcel.

6.1.5 Any existing in-ground disposal system in a development or new subdivision shall be decommissioned and removed to the satisfaction of the City Engineer if it is the intent of the developer to provide a new in ground disposal system or to connect to the Municipal Sewer System. Any existing sewage disposal systems shall be shown on the construction drawings.

6.2 Design Criteria

TABLE 6-1: Sewage Flow Design Criteria

Residential Flow	250 L/capita/day
Stormwater inflow/infiltration	14,500 L/ha/day for 10 year
Storm water Inflow/infiltration	20,000 L/ha/day for 100 year
Commercial Flow	20,000 L/ha/day
Industrial Flow	20,000 L/ha/day
Institutional Flow	20,000 L/ha/day

TABLE 6-2: Population Equivalent Table

Housing Unit Type	Persons per unit
Single Family	3.7
Multi Family – Low Rise	2.7
Multi Family- High Rise	2.5
Modular Homes	2.0
Non-Residential	80 per ha

TABLE 6-3: Main Pipe Parameters

Minimum \emptyset	200mm
Terminus piping (last 300m)	150mm at 2% grade
Minimum velocity:	0.61m/sec. at full pipe
Minimum gradient:	1.00% for terminal sections
Maximum velocity:	6.10m/sec
Roughness coefficients	0.013
Acceptance of existing systems	In accordance with the Official Community Plan and the Sewer Master Plan as directed by the City Engineer

TABLE 6-4 Sewer Pipe and Fittings

100mm to 150mm \emptyset	SDR 28 PVC to CSA B182.2 & ASTM D3034 (PS=625 kPa)
200mm to 375mm \emptyset	SDR 35 PVC to CSA B182.2 & ASTM D3034 (PS=320 kPa)
Greater than 375mm \emptyset	SDR 35 PVC to CSA B182.2 & ASTM D3034 or F794 (PS=320 kPa)
	Open profile PVC to CSA BV182.4 and ASTM F794 (PS=320 kPa)
	Dual wall corrugated profile PVC to CSA B182.4 and ASTM 794 (PS=320kPa)
All Fittings shall be compatible with the pipe to which they are attached. Inserta-Tees are not permitted.	

- 6.2.1 Pipes may be laid to the minimum vertical and/or horizontal radius of 60 metres or as recommended by the manufacturer, providing the design velocity (full pipe) is increased to 0.914 m/s for the curved section.
- 6.2.2 Mains shall have at least 1m cover and be deep enough to provide drainage at 2% minimum gradient from 600mm below basement floor elevation to obvert of pipe crown for new parcels. Cover shall be 0.6m at ditch inverts.
- 6.2.3 When a sanitary sewer pipe is installed such that it crosses below an existing asbestos cement (alc) watermain, the existing watermain material shall be replaced with ductile iron pipe for a distance of at least two (2) metres beyond each edge of the trench of the service crossing the watermain.

6.3 Manholes

- 6.3.1 Manhole structures shall be in accordance with MMCD S1 and S2. Manholes 3.0 to 5.0m deep to be 1200mm diameter, manholes deeper than 5.0m to be 1500mm diameter. (Bylaw No. 1817)
- 6.3.2 Manholes shall be provided at all changes in grade, pipe size, horizontal alignment (for non-curvilinear sewers) and at the upper end of mains not to be extended in the future. Only one curve, horizontal or vertical, is permitted between manholes. In addition to the foregoing, additional manholes shall be constructed so that the maximum distance between manholes is as shown in TABLE 6-5. Services 200mm and larger require a manhole when connecting to a mainline of the same size or larger. The invert of the incoming service shall match the centreline of the mainline pipe. (Bylaw No. 1817)

TABLE 6-5: Manhole Distance

Pipe size (mm Ø)	Maximum Distance (m)
375 and smaller	125
450 and 750	155
900 and larger	185

- 6.3.3 Manholes in gravel areas shall have a 1.5m square 50mm thick asphalt or 100mm thick concrete apron.
- 6.3.4 In cases where the sewer will be extended in the near future and the end of the present construction is within 45m of an existing manhole, the City Engineer may allow the use of a cleanout structure in accordance with drawing SS-S6 in place of a manhole.
- 6.3.5 Outside-drop manholes will be permitted, if in the opinion of the City Engineer, the circumstances preclude the use of normal manholes. These shall be constructed wherever the change in invert elevations through the manhole is greater than 600mm. Elevation changes greater than 600mm shall be by way of an outside drop only. Allowance shall be made in the design for the effect of the resulting turbulence on the hydraulic capacity of the system.

- 6.3.6 The relative elevations entering and leaving a manhole must not reduce the hydraulic capacity of the system
- 6.3.7 Allowances for energy losses or changes in velocity are to be determined in accordance with sound hydraulic principals.
- 6.3.8 The City Engineer may approve situations involving a large pipe flowing into a smaller pipe at steeper grade.
- 6.3.9 Stubs shall be placed in manholes to allow for future connections. The length of the stubs shall be 600mm maximum from the outside of the manhole. The end shall be securely capped to the satisfaction of the City Engineer. Grades shall be suitable for future extension of the system.
- 6.3.10 Manhole benching shall be a steel trowel finish with a constant grade from the inlet(s) to the outlet. The benching inside radius shall be no less than three times the branch diameter. Pre-benched manholes are permitted.
- 6.3.11 All channels shall be constructed to permit use of a pan and tilt camera having dimensions of 600mm x 150mm diameter.
- 6.3.12 The obvert of pipes entering a manhole shall not be lower than 50mm above the obvert of the outlet pipe. The internal channel in the manhole shall have an elevation difference of 5% from the inlet to the outlet.
- 6.3.13 Manhole and cleanout lids are to be set to match existing or planned grades both longitudinally and transversely. If the highway grade is greater than 6%, manhole castings shall be encased in a concrete surround poured to 150mm below the rim.
- a) 100mm high manhole frame castings are permitted in unpaved areas only.
- 6.3.14 All manhole barrel and sections shall be installed with rubber gaskets and mastic and shall be grouted inside with rapid set non-shrink grout. If, in the opinion of the City Engineer the water table may be high enough to affect the manhole, fibreglass bases in a concrete liner may be required.
- 6.3.15 Inlet and outlet pipes shall be grouted inside the manhole with rapid set non-shrink grout.
- 6.3.16 All manhole and cleanout lids must be cast to include "Langford Sanitary" (Bylaw No. 1817)

6.4 Service Connections

- 6.4.1 Sanitary sewer service connections of adequate size, but not less than 100mm^Ø shall be provided from a main to the property line of each new or existing parcel, which forms part of the development or which fronts a highway or other right-of-way in which the sewer is to be constructed and shall be constructed in accordance with MMCD S7.

- 6.4.2 All service connections shall be provided with an inspection chamber at the property line or at service the right-of-way boundary in accordance with drawing SS-S9.
- 6.4.3 All service connections shall terminate a distance inside the property line equal to the depth at the property line for new parcels unless otherwise approved by the City Engineer and at property line for existing parcels at a location agreed upon by the owner. All stubs must have a 1% minimum gradient from the inspection chamber into private property in accordance with the Building Code and 2% minimum from the sewer main to the inspection chamber, in accordance with the MMCD Documents.
- 6.4.4 Where deep sewers exist (those installed at greater than 3 meters below finished grade), the service stub shall be terminated within 1.0 vertical meters of the minimum basement floor elevation and marked with a 2x4 stake. The service connection shall have a long radius sweep and be installed at no more than 45 degrees from the vertical.
- 6.4.5 Duplex lots shall have a 100mm^Ø service connection to one inspection chamber. Lots with duplex potential shall have a 100mm^Ø service connection. (Bylaw No. 1555)
- 6.4.6 Wherever possible, adjoining residential type lots shall be serviced with one 100mm^Ø service connection with two 100mm^Ø stub and two inspection chamber (one for each lot) or may terminate at a 100x100x100 duplex inspection chamber.
- 6.4.7 Service locations shall be marked with a 40mm x 90mm stake painted red complete with a red insulated wire from a nail on the stake to the service connection cap with the depth marked.

6.5 Inspection Chambers

- 6.5.1 All inspection chamber (IC) lids and collars shall be installed in accordance with drawing SS S9. The lid cams shall be securely tightened to ensure that they are not subject to vandalism or misuse. (Bylaw No. 1494)
- 6.5.2 All inspection chambers shall have a cast iron chamber cover and concrete surround in accordance with drawing SS S9.
- 6.5.3 Any inspection chamber set in a slope greater than 3% shall have a cast iron chamber cover and concrete surround in accordance with SS S9.
- 6.5.4 Wherever an inspection chamber is covered by a cast iron chamber cover, the clearance between the cast iron lid and the plastic lid shall be a minimum of 75mm.
- 6.5.5 Inspection chambers shall be supplied and installed without plugs.
- 6.5.6 The inspection chamber lid shall be fastened to the riser pipe with a stainless steel machine bolt as provided by the manufacturer.
- 6.5.7 Where property line is within 1 meter of the backside of a sidewalk or curb the inspection chamber shall be installed using cast iron inspection chamber cover specified

in drawing SS S9, in a cast in place concrete apron protruding from the sidewalk or curb toward the property. This apron shall be constructed to the same engineering specifications as the sidewalk and shall provide a minimum of 200mm of concrete from the edge of the cast iron lid to the edge of the apron. An expansion joint at the sidewalk or curb to apron interface shall be provided.

- 6.5.8 Inspection chambers shall be a minimum of one meter apart from centre to centre when installed, unless, in the opinion of the City Engineer the clustering of services would be beneficial to site servicing and layout in which case the sewer and drain connections may be installed on one adjoining property line.

6.6 Force Mains

- 6.6.1 At the lowest pump delivery rate anticipated to occur at least once per day, a cleansing velocity of at least 0.9m/s shall be maintained. The maximum velocity should not exceed 3.5m/s.
- 6.6.2 An automatic air/ vacuum relief valve shall be placed at high points in the force main to prevent air locking, in accordance with good engineering practice.
- 6.6.3 Force mains should enter the gravity sewer system at a point not more than 600mm above the flow line.
- 6.6.4 The minimum size for mains discharging raw sewage shall be determined for each specific project by a Professional Engineer.
- 6.6.5 Force main service connections shall be a minimum 50mm \emptyset , and shall have a check valve and a ball valve at the property line.
- 6.6.6 Force main service connections shall be within 1 metre of the property line on the municipal right-of-way.
- 6.6.7 A tracer wire shall be installed for the purpose of locating the force main and a warning tape clearly marked "CAUTION BURIED SEWER LINE" shall be placed a minimum of 300mm and a maximum of 600mm above the obvert of the force main and service connections. The tracer wire shall be installed along the obvert of the force main and service connection.
- 6.6.8 All force mains shall be designed to prevent damage from imposed loads, or from water hammer or column separation phenomena.
- 6.6.9 Pipe bedding shall be a minimum depth of 150mm of sand under and 300mm above the pipe.
- 6.6.10 The minimum depth of a force main shall be 1.0 from finished grade.
- 6.6.11 Cleanouts shall be provided at all low points in the system and at the system terminus.

- 6.6.12 All force main ties to gravity feeds shall be designed to avoid confluence turbulence.
- 6.6.13 All force main gate valves shall be right hand closing and suitable for raw sewage application. Spacing shall be a minimum of 300m.
- 6.6.14 Check valves shall be provided where required for maintenance.
- 6.6.15 A gate valve on the force main from the pump station is required.
- 6.6.16 Force mains shall be hydrostatically tested to a minimum 150 psi for a minimum of 1 hour with zero allowable leakage.

6.7 Testing

- 6.7.1 All sewer systems must be tested to MMCD standards prior to Construction Acceptance. The contractor must provide the City Engineer with 24 hours notice of the test. (Bylaw No. 1494)
- 6.7.2 All sanitary sewers must be video inspected and the Professional Engineer must certify that all the videos have been viewed and that the sewer and connections are clean and free of defects prior to submission to the City Engineer for review.
- 6.7.3 CCTV videos and reports are to be accompanied with half size drawings. Air tests and videotaping are required prior to hot-mix asphalt concrete paving.
- 6.7.4 The system must be flushed and re-videoed prior to 1 year warranty inspection.
- 6.7.5 Minimum quality control test frequencies specified are the minimum number required to determine sufficient trench compaction. The contractor shall perform as many tests as are necessary to ensure that the works and services conform to the requirements of the contract regardless of the minimum number required as follows:
 - 6.7.5.1 Trench bedding (mainline) – one test for every 75m of trench. Minimum one between any two manholes.
 - 6.7.5.2 Trench backfill (mainline) – one test for every 75m of trench at each 1.0m fill depth. Minimum one between any two manholes.
 - 6.7.5.3 Trench bedding (service) – one per road crossing.
 - 6.7.5.4 Trench backfill (service) – one per road crossing at each 1.0m fill depth.
 - 6.7.5.5 Roadbase – one per road crossing.
 - 6.7.5.6 Roadbase – one for every 75m of trench with a minimum of one between any two manholes

SCHEDULE 7 – SEWAGE LIFT STATIONS

7. OBJECTIVES AND DESIGN CRITERIA

7.1. GENERAL: IT IS THE INTENT OF THIS DOCUMENT THAT ANY CONSTRUCTED LIFT STATION WILL BE A “TURN-KEY” PRODUCT.

7.1.1. The use of sewage lift stations is permitted providing all design options that would avoid lift stations have been considered. The City Engineer shall approve the proposed lift station location. Submersible sewage lift stations are preferred however, larger capacity sewage lift stations or lift stations with special design or siting requirements maybe considered.

7.1.2. Any lift station must be constructed fully functional, operational and with City-specified software installed. The SCADA (kiosk software) consultant shall be selected and retained by the City.

7.1.3. A preliminary design report shall be submitted by the Professional Engineer to ensure that the City’s concerns are addressed prior to commencement of detailed design. This report shall include a cost analysis for operation and maintenance. The report shall provide detailed information on the following design criteria in accordance with Sections 7.1.4 through 7.2.6 of this document.

7.1.4. Standby power and/or peakflow storage maybe required. The City Engineer shall determine which options are more economically feasible based on location, environmental concerns, storage capacity required and the availability of an external emergency power source. In the case of standby power, an on-site emergency generator is required. The selection of an appropriately sized generator for lift stations will be based on design criteria in accordance with this bylaw. The generator must be sized so that it will not be required to run at more than 80% of its total capacity while having all pumps running simultaneously. (Bylaw No. 1817)

7.2. LIFT STATION LAYOUT AND DESIGN CRITERIA

7.2.1. The structural, mechanical and electrical components of the lift station shall be designed to the OCP ultimate population build-out, in consultation with the Planning Department staff and in accordance with the City Sewer Master Plan for the designated catchment area(s).

7.2.2. Ideally, the lift station shall be located in an area where receiving sewers, water mains, and provisions for 3-phase power supply are concurrent and shall be located for convenience of operation and maintenance.

7.2.3. A Professional Engineer shall demonstrate that the lift station will have a minimal negative impact on the adjacent neighbourhood. These considerations should include, but not be limited to, lighting, odour, noise levels and maintenance operations.

- 7.2.4. The access shall be an asphalt driveway or approved alternate, for H2O loading. Adequate area must be provided adjacent to the lift station for maintenance vehicles with trailers to turn around. The maximum centerline grade of an access shall be no greater than 8% and have a cross-fall not exceeding 2%. Any deviation from this specification must be approved by the City Engineer.
- 7.2.5. Landscaping
- 7.2.5.1 A landscape plan shall be provided. The following items shall be adhered to:
- All utility boxes, including generators shall be wrapped with anti-graffiti wrap (all sides and top of box). Anti-graffiti wrap images shall be approved by the City Parks Manager.
 - 1800mm (6'-0") high cedar wooden fencing along property lines adjacent to residential housing.
 - Fully automatic irrigation system to City of Langford specifications.
 - Shrub, tree and groundcover planting to City of Langford Parks department approval.
- 7.2.6. Protection from vehicular damage for the kiosk shall be provided. The siting of the kiosk should be the primary method of protection; however, if suitable siting cannot be achieved, engineered concrete walls, berms, or other alternates may be used, as approved by the City Engineer. Any such protection devices must be compatible with the overall landscaping scheme and be engineered to withstand vehicular impact.
- 7.2.7. If the lift station is located in an existing or proposed residential area and, in the opinion of the City Engineer security or aesthetics are an issue, the kiosk and any above ground components of the lift station shall be enclosed in a building. The form and character of the building shall be residential in nature with an asphalt shingle gable roof and muted natural colour scheme.
- 7.2.8. Where the lift station is located in an area of drainage concern or flood plain, the station shall be designed as fully submerged. Electrical components shall be constructed above the 200-year flood elevation.
- 7.2.9. A Professional Engineer shall approve the ground conditions at the lift station location and shall certify that all geotechnical works carried out in conjunction with the lift station construction have been performed under their supervision.
- 7.2.10. Lift Stations providing service to more than 5 single-family dwellings shall use 3 phase power. Phase-converters are not permitted.
- 7.2.11. Functional odour control shall be incorporated into the lift station or, at the discretion of the City Engineer, future odour control shall be provided for.

- 7.2.12. Provide sufficient access to remove wet well components for repair, include mounting hardware for the City's davit hoist.
- 7.2.13. The minimum emergency or peak flow storage above the high level alarm shall be provided by a separate chamber. Storage shall be designed to accommodate a minimum of one hour of peak flow plus one hour of average daily flow, for maximum Official Community Plan build-out for the catchment area(s) or larger if, in the opinion of the City Engineer a larger catchment area shall apply.
- 7.2.14. Where standby power is required by the City Engineer, fuel degradation shall be addressed in the Design Report.
- 7.2.15. In the case where the valve chamber is a separate structure the design shall incorporate a flexible joint between it and the wet well structure.
- 7.2.16. Provide a 20mm diameter threadolet fitting and liquid filled pressure (100 ϕ face) gauges located on each pump header for testing purposes. Location as approved by the City Engineer.

7.3. WET WELL SPECIFICATIONS

- 7.3.1. Wet well design shall be certified by the Professional Engineer in consultation with the pump manufacturer. A report on hydraulics shall be provided including but not be limited to comment on air entrainment, vortexing and cavitation, and shall reflect the operation of the proposed pumps in the proposed wet-well design.
- 7.3.2. Provide a minimum 38mm water supply stand pipe with stop drain and Camlock fitting.
- 7.3.3. A water supply for wash down shall be provided within 10m of the station and be sized for available flow and pressure. A ball shutoff valve shall be provided. A reduced pressure principal backflow preventer shall be installed in accordance with the AWWA Canadian Cross Connection Control Manual (latest edition). Test results for the RP device shall be submitted to the City and CRD.
- 7.3.4. The piping arrangement shall make a provision for wet-well pump-out from an area near the access hatches. This may be achieved by a camlock fitting and piping sized appropriately for the City's maintenance contractor's pumper truck.
- 7.3.5. Provide a minimum 150 mm diameter aluminum or hot dipped galvanized pipe vent with vandal proof screen on the outlet for the ventilation of the wet well. Such vents shall be fitted with flanged fittings at the station roof to allow for future removal and adaptation for odour control devices. All accessory colours shall be in accordance with approved landscape designs.
- 7.3.6. The outlet pipe and all other connections to the station shall be brought to within 1.2 m of the expected ground line around the pump station by the use of risers either on the inside of the station or attached to the outside of the station.

7.3.7. The following coating specifications shall apply to the following components:

- 7.3.7.1. Steel piping shall be powder coated inside and out with 2 coats 3M “Scotch Kote” 206N fusion bonded epoxy coat to AWWA-C213. Surface preparation shall be SSPC-SP10, blasted clean.
- 7.3.7.2. Exteriors of valves shall be epoxy coated with 1 coat Cloverdale Paint “Prep-Tech” epoxy penetration sealer prime coat #83020 and 2 coats Cloverdale Paint “Clova Mas-Tic” epoxy #83100, minimum dry film thickness 6 mils.
- 7.3.7.3. Option for stainless steel piping (no coating) Type 316L to ASTM A312 Schedule 10S, Minimum wall thickness: long radius bends. Flanges to be full face 150 #CL slip or weld neck.

7.3.8. All concrete stations must be designed and constructed to prevent sulphide attack. The concrete surface of the wet well shall be treated with the following or as approved:

- 7.3.8.1. One coat Sherwin Williams “Kem Cati Coat” epoxy filler Dry Film Thickness (DFT) 10 mil and 1 coat Sherwin Williams “High Solids Catalyzed Epoxy Coat” DFT 6 mil, surface preparation in accordance with manufactures recommendations; or
- 7.3.8.2. One coat Canus Industries (604-552-2375) IMC-XYG UARD Series 4000, colour off white, DFT 4-6 mil, surface preparation shall be pressure wash and degrease; or
- 7.3.8.3. Two Coats Bar-Rust ICI 236 Devoe Coatings. Surface preparation shall be sweep blast and pre coat in accordance with manufacturers recommendations.

7.3.9. If, in the opinion of the City Engineer, the force main arrangement creates a maintenance issue where a flush valve may not be effective, pig loaders are required.

7.3.10. Any drain line from any chamber to the wet well requires a backflow preventer valve.

7.4. PUMPS

- 7.4.1. All pumps shall be Flygt three phase, solids handling pumps (one pump is to be complete with a mixing flush valve), or approved alternate.
- 7.4.2. Actual test results for the proposed pumps shall be provided to the City in order for efficiency to be confirmed.
- 7.4.3. The pump manufacturers must supply references for parts availability together with details of servicing expertise available.
- 7.4.4. Pumps are to be assembled complete with lift out slide rail system, cast iron discharge elbow; upper and lower guide rail support, pump rails and galvanized pump lifting chains.

- 7.4.5. Multiple pump scenarios shall meet maximum flow condition with one pump in failure mode.
- 7.4.6. Pumps shall have non-clog impellers that will pass a minimum 50 mm spherical solid.
- 7.4.7. All pump valves shall be located in a separate valve chamber. Alternate designs shall be subject to approval by the City Engineer. A check valve and isolation valve for each pump must be provided.
- 7.4.8. Locate the isolation valve and, where possible, locate the check valve in a horizontal position.
- 7.4.9. A water hammer and transient analysis must be performed.

7.5. LEVEL MONITORING SYSTEM

7.5.1. Level Measurement

- 7.5.1.1. Levels in the wet well shall be transmitted to the PLC by means of a submersible pressure transducer suspended within a stilling well in the wet well. (Bylaw No. 1817)
 - 7.5.1.1.1. Pressure Transmitter to be a Flygt/kpsi US100 or Blue Ribbon Bird Cage Submersible pressure sensor with a 4-20ma output.
 - 7.5.1.1.2. Stilling shall be fabricated from 150 ϕ SCH 40 PVC pipe perforated with 12 ϕ holes at 50mm c/c for the submerged section.
- 7.5.1.2. Two Flygt ENF-10 or approved equivalent float switches shall be mounted in the wet well to signal high level and low level alarm.
- 7.5.1.3. The float switches shall take control of the level measurement system upon failure of the pressure transmitter.

7.6. CHAMBER COVER, OPERATION AND MAINTENANCE PROVISIONS

- 7.6.1. Chamber covers shall be Flygt Safe-Hatch™ or approved equivalent (size to be approved by the City Engineer). An H-20 load rating shall be required where vehicular loads on the chambers are possible.
- 7.6.2. All chambers shall conform to Work Safe BC confined entry regulations.
- 7.6.3. A Work Safe BC approved aluminum ladder for access to wet well shall be provided. The location of the ladder shall not interfere with the removal and installation of the pumps and equipment. The ladder must be designed to extend and lock at a maximum of 600mm above the high water level float to permit wet well access, and at a distance above the roof of the wet well in accordance with current Work Safe BC regulations.

7.6.4. Where required by Work Safe BC regulations, an intermediary safety platform shall be provided. The platform shall be hot dipped galvanized “skid grid”.

7.6.5. A safety zone for maintenance personnel shall be provided.

7.7. CONTROL KIOSK DESIGN REQUIREMENTS

7.7.1. The lift station shall be equipped with a duplex or triplex automatic pump control kiosk in a powder coated aluminum enclosure for outdoor mounting.

7.7.1.1. The kiosk must be located a minimum of 3.0m from the station lid, and the control portion of the kiosk (with indicator lights and switches) shall face north (because of sun reflection concerns).

7.7.1.2. The kiosk shall be constructed so as the operators will be standing on a drained concrete pad at least three inches higher than the adjacent ground and at least one foot larger in dimension than the radius of all the door swings.

7.7.1.3. The internal panels of the control portion of the kiosk shall be hinged for ease of operation. The adjacent control enclosures shall be hinged at opposite sides to allow for both enclosures to be opened simultaneously allowing a service technician visual access to both enclosures simultaneously.

7.7.1.4. The kiosk construction shall meet the requirements outlined in this Schedule.

7.7.2. A luminaire shall be erected in accordance with Bylaw 1000 at the lift station site and shall be situated to provide adequate levels of illumination for the wet well and kiosk during emergency night-time events. The luminaire shall be a maximum of 3 metres from the kiosk.

7.7.3. Provide a Hand / Off / Auto (HOA) switch to operate and/or override photocell on luminaires.

7.7.4. Provide a separate 25mm orange communication conduit complete with a spare pull cord for this luminaire to the control equipment side of the kiosk for the antenna cable.

7.7.5. A variable speed explosion-proof exhaust fan with high and low speed switch (with VFD Program Module) must be used which will be running constantly at low speed and which has sufficient capacity to exchange the total volume of air inside the well at least 6 times an hour with means for detecting failure. At high speed, the fan must purge noxious fumes while maintenance personnel are in the wet well, per Work Safe BC Confined Space regulations. (Bylaw No. 1817)

7.7.6. The control kiosk shall contain the following components in the power distribution compartment:

7.7.6.1. Hydro pull box (as required by B.C. Hydro).

- 7.7.6.2. Main service disconnect breaker.
 - 7.7.6.3. B.C. Hydro meter base.
 - 7.7.6.4. Automatic transfer switch (rated the same as the main service disconnect) complete with network capability. (Bylaw No. 1817)
 - 7.7.6.5. Crouse-Hinds weatherproof 100A stand-by power receptacle (AR1042S22) when necessary.
 - 7.7.6.6. 125A Splitter (feeding transformer and control enclosure).
 - 7.7.6.7. Minimum 3kVA 600 to 120/240V transformer (protected by a fused switch). (Bylaw No. 1817)
 - 7.7.6.8. Light and light switch (3-way).
- 7.7.7. The control kiosk shall contain the following components in the control compartment:
- 7.7.7.1. An orange RPVC communication conduit(s) complete with a spare pull cord shall be provided from the control compartment of the kiosk to either a telephone/cable pole drop or an active underground telecommunication utility pull box. The telecommunication provider shall be approved by the City Engineer. The Contractor shall be responsible for making arrangements for the installation of the telephone or cable connection. (Bylaw No. 1817)
 - 7.7.7.2. 120/240V 24 cct. panel board (Square D).
 - 7.7.7.3. 1500W ceramic heater (on dedicated 15A circuit with receptacle).
 - 7.7.7.4. 120V GFI quadruple utility receptacle on a dedicated 15A circuit.
 - 7.7.7.5. MagMaster remote flow meter transmitter.
 - 7.7.7.6. Control enclosure containing PLC, control/indicator panel, motor disconnects, magnetic starters, overload protection, 24 Vdc control power supply, and all other control equipment.
 - 7.7.7.7. Light and light switch (3-way).
- 7.7.8. The control kiosk shall contain an operator control panel comprised of IDEC SLC30 series indicators, pushbuttons, and switches arranged in a 3x7 (duplex) or 4x7 (triplex) matrix as shown in Table 7-1.

TABLE 7-1: Control Kiosk Specifications

Pump 1 Run (Green Indicator)	Pump 2 Run (Green Indicator)	Pump 3 Run (Green Indicator)	Vent Fan Off-Low-High (3 Position Maintained)
HOA (3 Position Maintained)	HOA (3 Position Maintained)	HOA (3 Position Maintained)	347/600V Main Power (Green Indicator)
Pump 1 Status (Red Indicator)	Pump 2 Status (Red Indicator)	Pump 3 Status (Red Indicator)	120V Control Power (Green Indicator)
Pump 1 Over Temp (Red Indicator)	Pump 2 Over Temp (Red Indicator)	Pump 3 Over Temp (Red Indicator)	UPS Low Battery (Red Indicator)
Pump 1 Leak (Red Indicator)	Pump 2 Leak (Red Indicator)	Pump 3 Leak (Red Indicator)	High Level Float (Red Indicator)
Pump 1 Overload (Red Indicator)	Pump 2 Overload (Red Indicator)	Pump 3 Overload (Red Indicator)	Low Level Float (Red Indicator)
Reset (Round Red Pushbutton)	Reset (Round Red Pushbutton)	Reset (Round Red Pushbutton)	Lamp Test (Round Black Pushbutton)

All indicators shall be 24 Vdc LED type. Engraving shall be 4mm high.

7.7.9. Run-time totalizers for each pump shall be installed in the control panel for each pump directly below the column of indicators and controls for each pump as shown above.

7.7.10. The control kiosk shall be equipped with a GE Fanuc VersaMax PLC for control, monitoring, and SCADA functions. The following components shall be supplied, installed, and wired by the Contractor as shown in Table 7-2.

TABLE 7-2: Wiring Specifications for Control Kiosk

Part No.	Qty	Description
(a) IC200PWR002	1	24VDC(in)/3.3VDC(out) Power Supply
(b) IC200CPUE05	1	CPU Ethernet c/w 128K Memory
(c) IC200MDL650	1	32 point 24Vdc digital input card
(d) IC200MDL742	1	32 point 24Vdc digital output card
(e) IC200ALG260	1	8 point analog input card
(f) IC200CHS002	3	Carrier
(g) IC755CSS0RDA-AJ	1	HMI
(h) Deleted (Bylaw No. 1817)		

7.7.11. The PLC shall be mounted within the control enclosure and the HMI shall be mounted on the door directly to the right of the indicator/control panel. (Bylaw No. 1817)

7.7.12. The PLC software to operate the pump station must be provided by the City's software consultant. The Contractor shall demonstrate end-to-end functionality of each PLC point to the field equipment to the City Engineer prior to the software installation by the City's approved software consultant. The Contractor is responsible for commissioning the software. The Contractor shall supply all necessary equipment and wiring to provide the following points connected to the PLC (in the order shown – note that references to P3 can be deleted in the event of a duplex pump station).

7.7.13. Digital Inputs

TABLE 7-3: Digital Inputs for Control Kiosk

1	Cabinet intrusion on any door
2	347/600V power/phase loss (from Controlab DSP-1LS)
3	Communication Loss
4	Low battery
5	High wet well level (based on Flygt ENM-10 float switch)
6	Low wet well level (based on Flygt ENM-10 float switch)
7	Vent fan status (based on digital CT calibrated on low speed)
8	Lamp test button
9	P1 status (from aux. contact on starter)
10	P1 leak
11	P1 over temperature
12	P1 over load (from starter)
13	P1 reset button
14	P2 status (from aux. contact on starter)
15	P2 leak
16	P2 over temperature
17	P2 over load (from starter)
18	P2 reset button
19	P3 status (from aux. contact on starter)
20	P3 leak
21	P3 over temperature
22	P3 over load (from starter)
23	P3 reset button

7.7.14. Digital Outputs

TABLE 7-4: Digital Outputs for Control Kiosk

1	High level alarm indicator
2	Low level alarm indicator
3	347/600 power indicator
4	120 control power indicator
5	24DVC Failure
6	P1 run indicator
7	P1 status alarm indicator
8	P1 leak alarm indicator
9	P1 over temperature alarm indicator
10	P1 overload alarm indicator
11	P1 run (through 24Vdc/120Vac solid state relay and HOA to starter)
12	P2 run indicator
13	P2 status alarm indicator
14	P2 leak alarm indicator
15	P2 over temperature alarm indicator
16	P2 overload alarm indicator
17	P2 run (through 24Vdc/120Vac solid state relay and HOA to starter)
18	P3 run indicator
19	P3 status alarm indicator
20	P3 leak alarm indicator
21	P3 over temperature alarm indicator
22	P3 overload alarm indicator
23	P3 run (through 24Vdc/120Vac solid state relay and HOA to starter)

7.7.15. Analog Inputs (from ABB MagMaster)

TABLE 7-5: Analog Inputs for Control Kiosk

1	Discharge Flow (from ABB MagMaster)
2	Wet Well Level (from Flygt LS100 series pressure transducer)
3	P1 Amps (from analog CT)
4	P2 Amps (from analog CT)
5	P3 Amps (from analog CT)

7.7.16. The pump station shall be equipped with a Shaw cable hard wired service and modem for use with the City's SCADA system. The modem shall be mounted in a mounting bracket adjacent to the control compartment but not inside so as to permit easy access for viewing the indicator light and setting the reset button. The modem shall be connected through a router firewall to the communications port on the PLC.

7.7.17. Deleted. (Bylaw No. 1817)

- 7.7.18. The pump station shall be equipped with an uninterruptible power supply (UPS) to optimize signal strength (WPS) which supplies power to the PLC, CDPD modem, Magmeter, level sensor, and all other low voltage control devices and indicator lights. The UPS shall have enough capacity to power these devices for a period of 2 hours after the utility power has failed. The UPS shall provide dry contacts for utility fail and low battery for connection to the PLC. Interposing relays will be required to interface the PLC to UPS. The following UPS shall be supplied, installed, and wired by the Contractor: Powerware Corporation model #PW9125-700 UPS with a PW9125-24EBM extended battery. The Contractor shall provide the City with a ten year manufacturer's warranty for this UPS unit.
- 7.7.19. The pump station shall be equipped with an ABB Kent Taylor MagMaster flow meter (Model MFF/G) on the station discharge complete with remote transmitter with 3 line display and keypad, and 4-20ma interface for connection to the PLC. The Contractor shall submit the proposed bill of materials to the City Engineer for approval prior to procurement. The Contractor shall supply the City with a calibration certificate for the above noted meter. The digital readout from this meter shall show the rate of flow in litres per second and total volume pumped in cubic meters.
- 7.7.20. The Contractor shall submit shop drawings for the Kiosk, electrical and pump control system for approval by the City Engineer prior to fabrication.
- 7.7.21. Motor cables, power cables etc. must be continuous from within the pump station to within the kiosk unless an adequate exterior pull pit and junction box is installed.
- 7.7.22. Provide digital As-Built drawings based on the City's current "Construction Drawings and Drafting Standards" with elevations based on NAD 83 coordinates. Provide one laminated weather proof set and two paper sets of acceptably indexed operation and maintenance manuals as set out in this Schedule that contains all information for controls, monitors, pumps, and data collection. These manuals shall be contained within appropriate binders. A laminated wiring schematic shall be provided for all systems and permanently adhered to the inside of the right-hand control panel door.
- 7.7.23. Electrical Kiosk Design and Fabrication
- 7.7.23.1. This specification shall apply to the design, testing and supply of pump station kiosks. This specification is intended to establish the minimum quality benchmark for the enclosure, heating, and wiring (Figure 3).
- 7.7.23.2. For the purpose of this document, the kiosk shall mean a CSA-4 Housing complete with heating designed to contain electrical and electronic components.
- 7.7.23.3. All kiosks shall bear approval to nationally-recognized standards by organizations accredited by the Standards Council of Canada (e.g. CSA or Warnock Hersey).

- 7.7.23.4. The electrical / control kiosk shall be shipped and delivered to the site with 100% of the components installed and verified as per section 7.6.35. No after manufacturer assembly shall be permitted other than termination of connections for pump, transducer, floats, flow meter, antenna and luminaire.

7.7.24. Warranty

The Contractor shall warrant that all products are free from defects in material and workmanship. The warranty period shall be one year from the date of acceptance by the City. Any product warranties in excess of one year shall be assigned to the City. During this warranty period, the Contractor shall repair or replace any defective product free of cost to the City. This shall include all shipping costs. All defective products shall be repaired or replaced immediately upon notification. (Bylaw No. 1494)

7.7.25. Materials

- 7.7.25.1. All materials shall be new.
- 7.7.25.2. Unless otherwise noted, equipment shall be fabricated from 5052-H32 sheet aluminum of at least 3.2 mm (1/8 ins) thick.

7.7.26. Connecting Hardware

- 7.7.26.1. Miscellaneous hardware other than screws, nuts, bolts and washers shall be stainless steel. Other hardware coatings must be submitted to the City for approval.
- 7.7.26.2. Connecting hardware (i.e. screws, nuts, bolts and washers) 9.5mm diameter or smaller and shall conform to the following:
 - 7.7.26.2.1. All hardware shall have unified national thread form (ANSI) and shall be 18-8 or 316 stainless steel.
 - 7.7.26.2.2. All nuts and bolts 1/4-20 and larger shall have UNC (Unified National Course) threads and hexagon heads, and shall bear suitable markings to identify their grade and origin of manufacture.
 - 7.7.26.2.3. All machine screws smaller than 1/4-20 (e.g. 8-32 UNC, 1024 UNC) shall be Robertson pan-head. All screw heads shall be sized so only one screwdriver is required when working on the panels.
 - 7.7.26.2.4. No sheet metal or self tapping screws shall be used.
 - 7.7.26.2.5. No pressure adhesive cable ties shall be used where equipment and/or wiring is to be mounted to the inside of the control enclosure doors, a 3.2mm powder coated aluminum stand-off liner shall be welded to the inside of the door to facilitate the use of fasteners.

7.7.27. Fabrication

- 7.7.27.1. All welds shall be in accordance with CAN/CSA W59.2 - Welded Aluminum Construction or be certified by a Professional Engineer (in an appropriate field) registered in the Province of BC.
- 7.7.27.2. All exterior seams shall be of continuously welded construction. All exterior welds shall be ground smooth.
- 7.7.27.3. All welds shall be free of slag and spatter.

7.7.28. Kiosk Doors, Hinges and Door Gaskets

- 7.7.28.1. Kiosk doors shall be fabricated from sheet aluminum and have a separate stiffening panel welded to the inside door skin.
- 7.7.28.2. Kiosk doors shall be hinged to the kiosk using three hinges evenly spaced on each door. The hinges shall be non ferrous metal and equipped with a grease nipple for lubrication such as Marr Weld-On Hinge Limited Model #AFSSP-10GF.
- 7.7.28.3. Each door shall have a door stop to hold the door open at 90 degrees.
- 7.7.28.4. The gasket shall be of one continuous piece per side (i.e. four strips per opening) and shall be permanently bonded to the metal.
- 7.7.28.5. The gasket shall be of an appropriate length so as not to have gaps at gasket joints or to shrink over time. The surface of the gasket shall be covered with a silicon lubricant to prevent sticking to the mating surface.

7.7.29. Cabinet Internal Lighting

The power distribution and control compartment on the kiosk shall be equipped with a 100W equivalent LED rough usage bulb, receptacle, and light switches. The two light switches shall be wired as a three-way circuit. (Bylaw No. 1817)

7.7.30. Kiosk Environmental Requirements

Each kiosk shall be equipped with a 1500W ceramic heater complete with fan. This heater shall be installed on a shelf mounted near the bottom of the kiosk in the control section.

7.7.31. Equipment Mounting Panels

Equipment mounting panels shall be constructed from 5052-H32 sheet aluminum of at least 4.7 mm thick. The equipment mounting panels shall extend horizontally from wall to wall and vertically from the fan/light mounting panel to the bottom of the kiosk base as shown on the "Approved for Construction" drawings for the subject project. Equipment mounting panels may also be constructed of 10 gauge powder coated sheet steel. All equipment mounted to such panels shall be fastened with 8-32 screws.

7.7.32. Kiosk Electrical Equipment

- 7.7.32.1. The Contractor shall supply all electrical equipment as described in the bylaws and shown on the drawing. Alternative products must be approved by the City prior to start of fabrication.
- 7.7.32.2. The Contractor shall provide equipment layout details with the shop drawings.
- 7.7.32.3. An inner mask shall be installed to protect personnel from electrical hazard. The mask shall have cut-outs for circuit breaker toggle mechanisms. Knock outs in the mask shall be provided for all spare breaker spaces.
- 7.7.32.4. All equipment shall be mounted on to the equipment mounting panels and shall be secured using 8-32 inserts.
- 7.7.32.5. All equipment shall be labelled using vinyl adhesive equipment labels with 10 mm high black characters on a white background as shown in Figure 7-1.
- 7.7.32.6. All panels shall be supplied with the breakers installed.

7.7.33. Control Wiring

All wiring shall be completed in accordance with the following requirements:

- 7.7.33.1. Figures 7-1 and 7-2 illustrate control wiring methods and standards, and are also used to establish the minimum quality benchmark.
- 7.7.33.2. All conductors shall be stranded RW90 unless otherwise noted. Conductor size and color-coding for control wiring shall be as shown in Table 7-6.
- 7.7.33.3. The wiring shall be neatly bundled and ty-rapped to the equipment mounting panel at 150 mm intervals as shown in Figure 7-1.
- 7.7.33.4. All wire bundles shall be formed by using a single ty-wrap.
- 7.7.33.5. No ty-wraps or any other wire bundling device shall be found inside or partly inside any wire bundles.
- 7.7.33.6. All wiring shall take the neatest route to its termination point.
- 7.7.33.7. All wires shall be free of splices or through connections in their entirety.
- 7.7.33.8. Provide 8-32 inserts and ty-rap mounts for the attachment of wiring as shown in Figure 7-1.
- 7.7.33.9. Wiring and terminal blocks shall be labelled according to the conventions shown in Table 7-7. All wiring and equipment mounting shall be done in a neat manner as shown in Figures 7-1 and 7-2.

TABLE 7-6: Conductor Color Code for Control Wiring

Colour	Size	Purpose
Orange	Number 16-RW90	Low-voltage control wiring
Red	Number 14-RW90	120 volt control wiring
Black	Number 14-RW90	Hot
White	Number 14-RW90	Neutral
Green	Number 14-RW90	Ground

TABLE 7-7: Control Wiring Labelling Conventions

DESCRIPTION	CONDUCTORS	CABLES	NOTES
Local Control	LC-001	LCC-01	1
Remote Control	RC-001	RCC-01	1
Neutral	N3, N3-1	n/a	2,3
Hot	H3, H3-1	n/a	2,3
24 Volts AC	24AC, 24AC-1	n/a	
24 Volts AC (return)	24N, 24N-1	n/a	
Terminal Blocks	-	-	4
Notes: 1. Local specifies termination inside the control cabinet and remote indicates termination outside. 2. If there is more than one conductor of the same type within a bundle or cable, the conductors are labelled sequentially starting from one 3. Hot and neutral circuits are labelled Hx or Nx where x is the circuit number in the panel. 4. Terminal blocks are numbered sequentially, fused terminals are preceded by an 'F', and ground terminals are preceded by a 'G'.			

TABLE 7-8: Terminal Block Part List

DESCRIPTION	DESCRIPTION
WDU6 Terminal	102020
WPE6 Ground Terminal	101020
WAP2.5-10 End Section	105000
WEW 35/2 End Bracket	106120
WTW 2.5 - 10 Partition	105010
WSI 6/2 Fuse Terminal	101400
WOV6 Jumper Bar	As required
TS35 Mounting Bar	38340

Figure 7-1

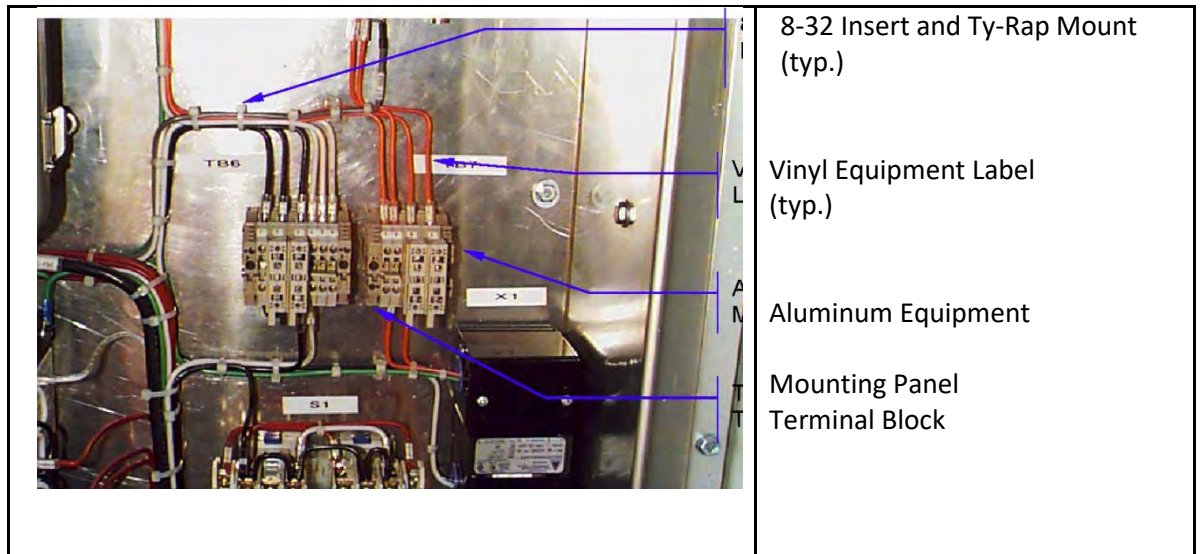

- 8-32 Insert and Ty-Rap Mount (typ.)
- Vinyl Equipment Label (typ.)
- Aluminum Equipment Mounting Panel
- Terminal Block

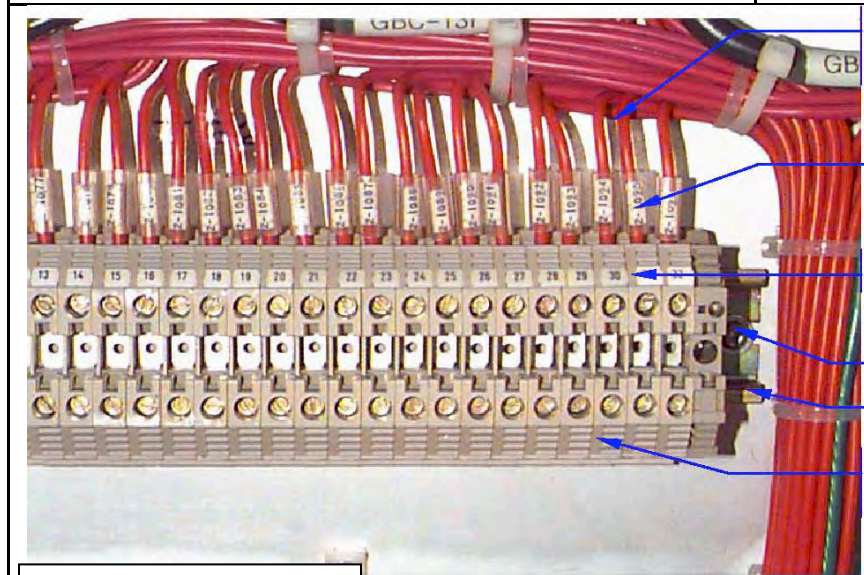

- 120 Volt Red Control Wire (typ.)
- Grafoplast Wire Marker (typ.)
- Terminal Block Label EndBracket
- Mounting Bar
- Terminal Block

Figure 7-2

7.7.33.10. All control wiring shall be labelled using wire markers from Grafoplast as shown on Figure 7-2.

7.7.33.11. Terminal blocks shall be supplied from Wiedmuller or approved alternative.

7.7.34. Kiosk Finish

The kiosk shall be finished as follows:

7.7.34.1. The enclosures shall be powder coated gray. The Contractor may alternatively submit proposed powder coat procedures to the City representative for approval.

- 7.7.34.2. The final product shall be free of dents, scratches, weld burns and abrasions harmful to its strength and general appearance.
- 7.7.34.3. All exterior corners shall be rounded to a radius of 3.17 mm (1/8 ins) minimum.
- 7.7.34.4. All sharp edges shall be de-burred to a radius of 0.4 mm (1/64 ins) minimum in order to reduce hazards to service personnel.

7.7.35. Testing

The Contractor shall perform testing of all control wiring including heating and ventilation within each kiosk. The tests shall be witnessed by the City Engineer and the City SCADA consultant.

7.7.36. Product Review

The City will require the following conditions to be met prior to delivery:

- 7.7.36.1. The cabinets and wiring have been reviewed and accepted by the City Engineer.
- 7.7.36.2. The cabinets shall be 100% complete and operational (see 7.6.22.4).
- 7.7.36.3. All control wiring shall be tested to the satisfaction of the City Representative.
- 7.7.36.4. Any equipment which has been rejected shall be repaired or replaced within a time period acceptable to the City. All costs associated with these repairs and for the testing of a failed product will be borne exclusively by the Contractor.

7.7.37. Manufacturers Identification

- 7.7.37.1. The City will allow the manufacturer to externally identify the kiosk as to its origin.
- 7.7.37.2. The location, size and method must be visually pleasing and approved by the City prior to implementation.
- 7.7.37.3. All labelling installed by the manufacturer shall be set square on the kiosk.
- 7.7.37.4. Adhesive stickers shall not be used in labelling the kiosk exterior.

7.7.38. Labelling

- 7.7.38.1. All products shall be labelled with the Contractor's company name, model number, panel rating and the date of manufacture. This label shall be located on the inside of the kiosk in an easy to read location.
- 7.7.38.2. The Contractor shall also provide aluminum engraved labels with black painted lettering on the outside of each kiosk. The wording for the kiosk ID plate will be provided by the City.

- 7.7.38.3. All ID plates shall have 15 mm high characters and shall be attached to the door using a minimum of 4 stainless steel 8-32 machine screws complete with blind PEM fasteners.

7.7.39. Plan Pouch and Portable Computer Shelf

- 7.7.39.1. The Contractor shall supply and mount a waterproof plan pouch (400mm high 500mm wide) on the inside of the left door of the control compartment. The pouch shall be secured to the inside.
- 7.7.39.2. The Contractor shall supply a 400mm deep by 500 mm wide fold down shelf attached to the inside left-hand control panel door. The shelf shall be large enough to hold an open 75mm ring binder and shall have a 6mm restraining lip on the three outer edges.

7.7.40. Shop Drawings

7.7.40.1. Submission

- 7.7.40.1.1. Detailed dimensioned layout shop drawings (i.e. manufacturing drawings) including plans, elevations, sections, equipment layout and wiring diagrams (if required) for each kiosk.
- 7.7.40.1.2. Technical brochures for materials and equipment as required.

7.7.40.2. Drawing Format

The drawing format shall be as follows:

- 7.7.40.2.1. In AutoCAD and PDF format (most current release.)
- 7.7.40.2.2. Produced on ISO A1 size paper (other sizes shall meet the approval of the City Representative).
- 7.7.40.2.3. In metric units only.
- 7.7.40.2.4. Legible when reduced to 1/2 size.
- 7.7.40.2.5. In accordance with CSA Standard CAN/CSA-B78.2-86 - Dimensioning and Tolerancing of Technical Drawings.

7.7.40.3. City Review

The City Review of the shop drawings will be as follows:

- 7.7.40.3.1. Drawings will be reviewed by the City Engineer solely to ascertain conformance with the general design concept. Responsibility for approval of detail design inherent in the drawings rests solely with the Contractor. The review by the City Representative shall not constitute approval.

7.7.40.3.2. Review by the City Engineer shall not relieve the Contractor of its responsibility for errors or omissions in the drawings or for proper completion of the work in accordance with the contract documents. The City Engineer may review all design drawings and return any comments to the Contractor seven days after receipt.

7.7.40.3.3. The Contractor is responsible for verification and correlation of field dimensions, fabrication processes, techniques of construction, installation and co-ordination of all parts of the work.

7.7.40.3.4. After the City Review, the drawings will be returned to the Contractor. The Contractor shall revise the drawings to the satisfaction of the City Engineer prior to fabrication.

7.7.41. Packaging

7.7.41.1. Shipping documentation shall include the purchase order number and an itemized bill of materials.

7.7.41.2. Each kiosk shall each be lag bolted to two 10cm x 10cm posts along the shorter sides of the kiosk to be used for support when the kiosk is being lifted or moved.

7.7.41.3. Any product damaged in shipping shall be repaired or replaced at no extra cost to the City. The Contractor will assume all responsibility for getting the product to the City in proper working order.

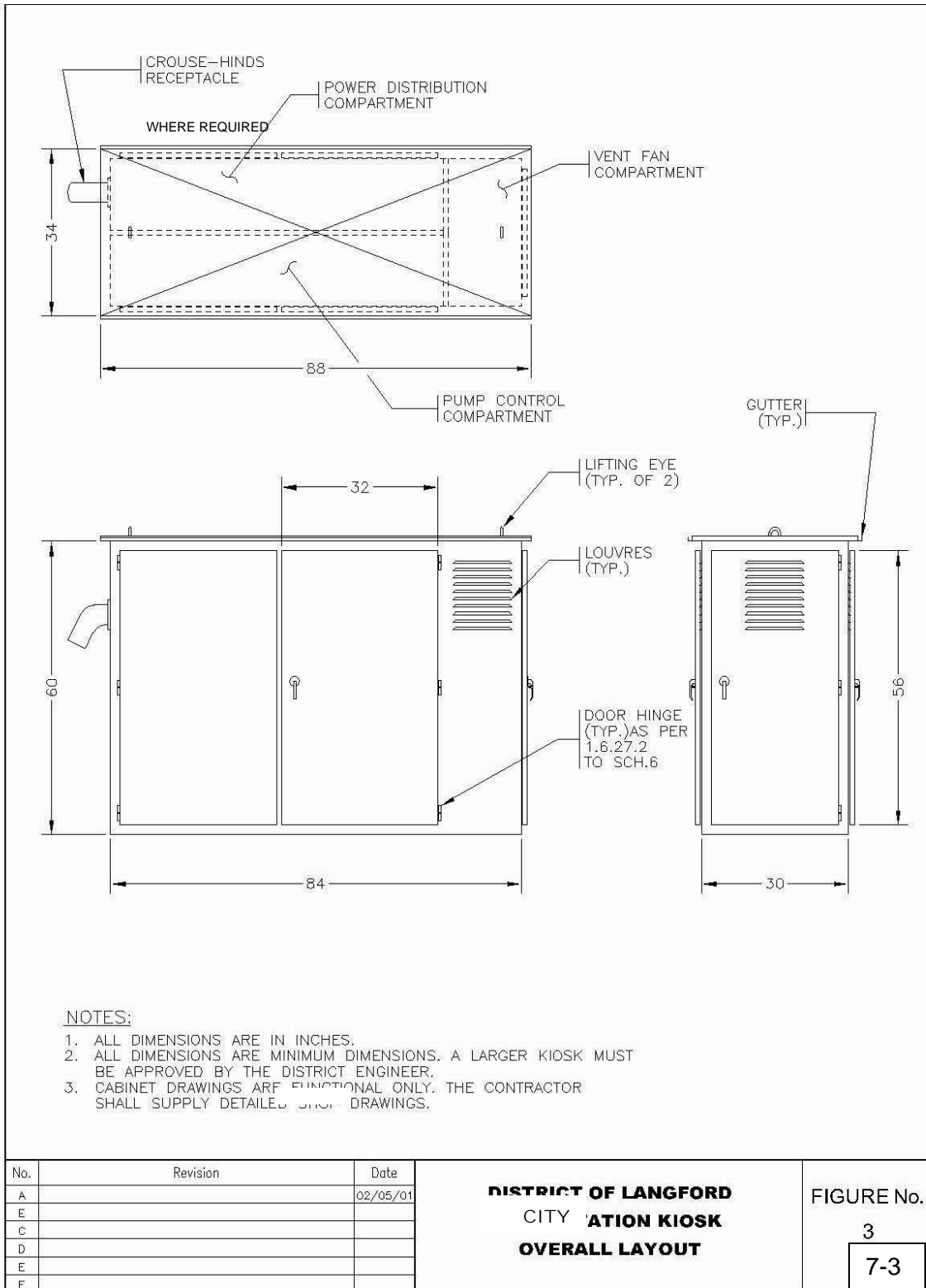

7.8. GENERATOR CRITERIA

7.8.1. ELECTRICAL

- 7.8.1.1. The generator should be Manufactured by Kohler/John Deere (diesel type) sized so that it will not be required to run at more than 80% of its total capacity while having all pumps running simultaneously and based on the following information: (Bylaw No. 1817)
 - 7.8.1.1.1 The generator shall be equipped with a 15 Amp - 110 volt receptacle.
- 7.8.1.2. The generator shall have provisions to reverse the phase rotation through a transfer switch.
- 7.8.1.3. The generator shall be permanently wired to the control kiosk.
- 7.8.1.4. The generator will be designed to have minimal impact on adjacent property owners. Therefore, sound attenuation will be extremely important. A maximum sound emission of 65 dba's at 6 meters will fulfill this requirement.
- 7.8.1.5. This generator shall be in a suitable weather enclosure to protect it against vandalism and deterioration due to weather.
- 7.8.1.6. The generator shall be permanently mounted on a suitably sized reinforced concrete pad.

7.8.2. REMOTE MONITORING

- 7.8.2.1. The generator shall be linked to the lift station PLC thus enabling an operator to remotely monitor the operation of the generator.
- 7.8.2.2. The generator will have fully electronic monitored features including the following:
 - 7.8.2.2.1. fuel level
 - 7.8.2.2.2. oil pressure indicator
 - 7.8.2.2.3. battery voltage
 - 7.8.2.2.4. coolant temperature
 - 7.8.2.2.5. generator output in volts and Amps
 - 7.8.2.2.6. an external temperature sensor which will activate a circulating 1500 Watt block heater
 - 7.8.2.2.7. The controller for remote start up

7.8.2.2.8. High temperature emergency shut down

7.8.2.2.9. Low oil pressure emergency shut down

7.8.2.3. Weatherproof junction boxes shall be mounted on a rigid steel post adjacent to the Generator location. One junction box will contain the communications connection from the PLC to the generator controller. A minimum 16-pair industrial grade cable will be permanently wired to the controller at the generator with enough cable to comfortably extend to the weatherproof junction box. The second junction box will provide power to the 1500-watt block heater.

7.8.2.4. The contractor shall be responsible for all City consulting electrical engineers costs incurred for PLC and central monitoring station software upgrading, commissioning and testing.

7.8.3. MAINTENANCE MANUALS AND WARRANTY

7.8.3.1. Maintenance manual shall be in accordance with Section 7.9 of this Schedule.

7.8.3.2. The Warranty Period shall, despite any other provision of this Bylaw, be two years from the date of Construction Acceptance. (Bylaw No. 1494)

7.9. OPERATION AND MAINTENANCE MANUAL CRITERIA

The operation and maintenance manual for the lift station shall comply with the following format:

7.9.1. SYSTEM DESCRIPTION AND OPERATION REQUIREMENTS

7.9.1.1. General

7.9.1.2. System description

7.9.1.3. Operator attendance

7.9.1.4. Utilities & maintenance contracts

7.9.1.5. System modifications

7.9.1.6. Operator's duties & responsibilities

7.9.2. SUPERVISION & MAINTENANCE OF SEWAGE PUMPING STATION

7.9.2.1. Introduction

7.9.2.2. Maintenance of works and site

7.9.2.3. Weekly maintenance

- 7.9.2.4. Preventive maintenance
- 7.9.3. OPERATION AND MAINTENANCE OF PIPELINES
 - 7.9.3.1. General requirements
 - 7.9.3.2. Gravity Sewers
 - 7.9.3.3. Forcemain
- 7.9.4. CONTROL AND INSTRUMENTATION PHILOSOPHY
 - 7.9.4.1. General Description
 - 7.9.4.2. Sewer Effluent
 - 7.9.4.3. Manual Station Isolation
 - 7.9.4.4. Wet well level control
 - 7.9.4.5. Normal pumping sequence
 - 7.9.4.6. Emergency backup level control
 - 7.9.4.7. Surge Protection
 - 7.9.4.8. Station Instrumentation
 - 7.9.4.9. Electrical system
 - 7.9.4.10. Programmable logic control system
- 7.9.5. CONTROL SYSTEM
 - 7.9.5.1. General
 - 7.9.5.2. Normal level control system
 - 7.9.5.3. Emergency level control system
 - 7.9.5.4. Programmable logic controller
 - 7.9.5.5. Relay backup system
 - 7.9.5.6. Station display panel
 - 7.9.5.7. Station interface panel
 - 7.9.5.8. Low voltage power supply

7.9.5.9. Surge control system

7.9.5.10. Wash down water system

7.9.6. PROCESS SYSTEM

7.9.6.1. Sewage pumping equipment

7.9.6.2. Lifting equipment

7.9.7. ELECTRICAL

7.9.7.1. General

7.9.7.2. Main switchgear

7.9.7.3. Operations Manual for standby generator

7.9.8. MANUAL & EMERGENCY OPERATING PROCEDURE

7.9.8.1. General

7.9.8.2. Gravity sewer blockage

7.9.8.3. Pumping equipment failure

7.9.8.4. Forcemain failure

7.9.8.5. Power failure

7.9.9. OPERATION & PREVENTATIVE MAINTENANCE OF PUMPS

7.9.9.1. General

7.9.9.2. Troubleshooting

7.9.9.3. Startup summary

APPENDICES

A Instrumentation index and specification sheets

B Mechanical equipment specification sheet

C Utility contracts

D Maintenance contracts

E Warranty Certificates

7.10. POWDER COAT SUPPLY SPECIFICATION

7.10.1. POWDER COAT SELECTION CRITERIA

7.10.1.1. Powder coat shall be of type Polyester-TGIC.

7.10.1.2. Powder coating products used for coating aluminum components shall meet the following requirements¹ :

7.10.2. POWDER COAT APPLICATION

7.10.2.1. Scope

This specification shall apply to the application of powder coating products on aluminum components.

7.10.2.2. General requirements

7.10.2.2.1. The powder coating process, as specified below, shall be tested on at least one piece from a given batch of aluminum components to ensure a high quality coating for that type of component before the complete batch is powder coated. If there is uncertainty about the quality or appearance of the powder coating, City approval shall be acquired.

7.10.2.2.2. Where possible, items to be powder coated shall be free of dents, scratches, weld burns, ripples, pits, and abrasions before powder coating.

7.10.2.2.3. Removable components which may be damaged by the powder coating process shall be removed before powder coating and reassembled after powder coating.

7.10.2.2.4. Mask all threaded hardware and tapped holes as required.

7.10.2.3. Pre-Treatment¹

The powder coating pre-treatment shall include the following steps:

7.10.2.3.1. Alkaline cleaning, (or equivalent) as required, to remove process oil, grease, and dirt.

7.10.2.3.2. Rinsing as required.

7.10.2.3.3. Multi-metal Iron Phosphate coating or Dried in Place pre-treatment to increase corrosion resistance and improve paint adhesion. Follow chemical

¹ If Dried in Place pre-treatment method is used in step 3, steps 4 and 5 are not required.

supplier's specifications. Chemical concentration, temperature, and timing specifications must be followed precisely.

7.10.2.3.4. Rinsing as required.

7.10.2.3.5. Non-Chrome (or equivalent) sealer coating to provide additional corrosion protection. Follow chemical supplier's specifications. Chemical concentration, temperature, and timing specifications must be followed precisely.

7.10.2.4. Drying / Pre-heating

All items to be powder coated must be completely dry and pre-heated as required to help prevent out-gassing before powder coat application.

7.10.2.5. Application

7.10.2.5.1. Powder coat shall be of type Polyester-TGIC.

7.10.2.5.2. For porous castings, a powder coat type shall be selected to help prevent out-gassing.

7.10.2.5.3. Powder coat must be applied to meet the powder coat manufacturer's specifications.

7.10.2.5.4. Powder coat thickness shall be no less than 2.5 mils at any location.

7.10.2.5.5. Full-coverage of interior and exterior surfaces is required, unless otherwise specified in the contract, with no light spots allowed on exterior surfaces.

7.10.2.6. Final Appearance

7.10.2.6.1. All powder coatings shall be smooth, substantially free of contamination, flow lines, light spots, powder build-up, powder washout, streaks, sagging, runs, blisters and other defects that would in any way impair serviceability or detract from the general appearance.

7.10.2.6.2. Orange peel appearance shall be reduced as much as possible, however, where unavoidable, orange peel appearance shall be consistent and visible only at short ranges.

SCHEDULE 8 - WATER SUPPLY

8. Water Supply General

8.1. Each parcel in a subdivision within the City of Langford shall have a water supply provided by the City or Capital Regional District Water Service (CRDWS) as determined by the City Engineer.

8.1.1. All designs for extensions of the City or CRDWS water system shall be reviewed and approved by a drinking water officer in accordance with the *Drinking Water Protection Regulations* under the *Drinking Water Protection Act*.

8.1.2. Individual wells may be permitted in areas outside the CRDWS service area provided that each parcel shall have a proven source of potable water of not less than 4000 litres per day.

8.1.3. Individual wells are permitted for non-potable water uses on City owned land.

8.1.4. Where water is to be supplied by the CRDWS, the CRDWS specifications shall have precedence. If CRDWS specifications are silent on any issue, the specifications in this schedule shall apply.

8.1.5. Each parcel in a subdivision or development which is provided with a water supply from the City or CRDWS shall have sufficient pressure in the water supply at the property line to meet the requirements of the BC Building Code and shall be shown to have sufficient pressure to meet the requirements of the BC Building Code for water pressure at the faucet at the highest point at which a plumbing fixture could be installed on the parcel having regard to the restrictions in the City Zoning Bylaw and in any Covenants registered on the property. A Professional Engineer shall approve and certify the required pressures.

8.2. Water Supply Facilities

8.2.1. Where water supply facilities (pump station or PRV station) are located within a road right of way or a statutory right of way in favour of the CRDWS and/or the City of Langford within private property, the facility meet the following landscape requirements:

8.2.1.1. A landscape plan shall be provided.

8.2.1.2. All utility boxes, including generators to be wrapped with anti-graffiti wrap (all sides and top of box). Anti-graffiti wrap images shall be approved by the City Parks Manager.

8.2.1.3. 1800mm (6'-0") high cedar wooden fencing along property lines adjacent to residential housing.

8.2.1.4. Fully automatic irrigation system to City of Langford specifications.

- 8.2.1.5. Shrub, tree and groundcover planting to City of Langford Parks department approval.
- 8.3. Delete. (Bylaw No.1669)
- 8.4. Network Requirements
 - 8.4.1. Where a final road pattern of a subdivision creates a watermain network with excessive dead ends, a supplementary connection of a minimum of 150 mm diameter shall be required to an existing main and may necessitate the provision of a Right-of-Way over private property in favour of the City.
- 8.5. Delete. (Bylaw No.1669)
- 8.6. Delete. (Bylaw No.1669)
- 8.7. Delete. (Bylaw No.1669)
- 8.8. Delete. (Bylaw No.1669)
- 8.9. Separation to Other Services
 - 8.9.1. At any location there shall be a minimum horizontal clearance of 3m between a watermain and a sanitary sewer or storm drain. The Consulting Engineer shall first obtain approval of the Regional Public Health Engineer if an alternative is to be proposed.
 - 8.9.2. At any location there shall be a minimum horizontal clearance of 1m between a watermain and any other existing or proposed underground services or open ditches.
 - 8.9.3. Watermains shall not be located within 1 m of any utility pole.
 - 8.9.4. Where it is necessary for a watermain to cross other underground services the crossing shall be made at an angle greater than 20°. The vertical clearance between sanitary sewers or storm drains and the watermain at the crossing point shall be not less than 450mm. For all other services, the vertical clearance shall be not less than 150mm.
- 8.10. Delete. (Bylaw No.1669)
- 8.11. The watermain replacement work shall be done by the City or CRDWS at the Applicant's expense, and this shall be indicated on the Design Drawings.
- 8.12. Delete. (Bylaw No.1669)
- 8.13. Delete. (Bylaw No.1669)
- 8.14. Delete. (Bylaw No.1669)
- 8.15. Fire Hydrants

- 8.15.1. For one and two family residential development, the centre of the building envelope as identified in Bylaw 300 for the appropriate zone shall be within 150 metres of a fire hydrant, measured along the access route as defined in Building Bylaw No. 1160 and along the highway to which the access route connects. For all other building types fire protection shall be as prescribed by Building Bylaw 1160.
- 8.15.2. For Commercial, Industrial, Institutional and Multi Family Zones, as identified in Bylaw 300, fire hydrants are required every 90 metres.
- 8.15.3. In addition to the requirements of this bylaw, fire hydrants shall be located at 150 metre intervals along all collector and arterial roads regardless of the density of development adjacent. For 4 lane arterial roads with, or designated to be constructed with a raised median, fire hydrants shall be located on both sides of the road at 250 metre spacing per side.
- 8.15.4. Fire flow demand shall be in accordance with the current "Water Supply for Public Fire Protection", by the Fire Underwriters Survey (FUS) for the existing or anticipated land use. Residual pressure at the flow rate shall not be less than 140 kPa (20psi) anywhere in the water network.
- 8.15.5. For residential applications only, If FUS recommended fire flows are not available, or the subject property is outside the Capital Regional City Water Services service area, a reduction to the prescribed fire flows may be permitted providing the property is charged with a s.219 of the Land Title Act covenant that requires all buildings over 300 square feet in floor area to be provided with residential fire sprinklers in accordance with NFPA 13D. (Bylaw No. 1669)
- 8.15.6. Fire Hydrants on private property shall be protected by a statutory right-of-way in favour of the City or CRDWS for maintenance.
- 8.15.7. Hydrants shall be as per MMCD W4.
- 8.15.8. Hydrants shall be located in the boulevard and should preferably be located at or near a street intersection; otherwise they may be located on the projection of the property line dividing two lots. In selecting the location for a hydrant, the probable route of the fire engine shall be considered.
- 8.15.9. A hydrant shall not be located within 3 m of a utility pole or light standard, within 1 m horizontally of underground service pipes or open ditches, or within 2.2 m of the curb line.
- 8.15.10. Whenever practical, hydrants shall be near the highest and/or lowest point of the watermain.
- 8.15.11. The design drawings shall indicate the final elevation to which the hydrant flange is to be set. Any adjustments required after the system is in service will be made by the City at the Applicant's expense.

8.16. Air Relief Valves

- 8.16.1. Air relief valves shall be as per MMCD W6.
- 8.16.2. Provision shall be made for expelling air by the installation of air relief valves where necessary.
- 8.16.3. Double acting air valves shall be installed at all high points on watermains 200mm and larger.

8.17. Flush Valves

- 8.17.1. Flush valves shall be as per Drawing W8SS.
- 8.17.2. Flush valves shall be installed at all dead ends.
- 8.17.3. Provision shall also be made for expelling air during filling by the installation of double acting air valves or test points where necessary. The initial flush shall be through a port which shall be a minimum of ½ the diameter of the main.

8.18. Service Connections

- 8.18.1. Service connections shall be installed to each proposed lot in a development or to each duplex dwelling unit, shall be connected to the main in a road allowance, and shall be installed at right angles to the main, within the boundaries of the lot being served, except in the turning area of a cul-de-sac. No service connection is to be provided to a lot by way of a private easement over another property.
- 8.18.2. Service connection separation shall meet the CRDWS separation requirements. (Bylaw No. 1494)
- 8.18.3. Traffic islands with planting areas shall be provided with a 19mm water service.
- 8.18.4. On a panhandle lot, service connections shall be extended from the meter location along the access strip to the main body of the lot at the time of subdivision development.
- 8.18.5. If a development requires a private fire line as well as a domestic water service, the fire line shall be completely separate from the domestic service.

8.19. Backflow Prevention

- 8.19.1. There shall be no physical connection between a public and a private potable water supply system, nor between either a water system and a sewer or appurtenance thereto, which would permit the passage of private water or any sewage or polluted water into the potable public supply.
- 8.19.2. No pipe, valve or fitting which has been exposed to raw sewage shall thereafter be included in a potable water system, either temporarily or permanently.

SCHEDULE 9 ELECTRICITY AND TELECOMMUNICATIONS

9. General

- 9.1. Deleted (Bylaw No. 1513)
- 9.2. Every extension of electrical and telecommunications services to a subdivision or development and any such services installed to a building constructed under the City of Langford Building Bylaw, shall be installed underground in ducts except in areas identified in the Street Atlas as Cross Section R17.
- 9.3. Where a proposed single family residential subdivision creates new lots that front on an existing highway serviced by overhead wires or a building permit is issued for a single family dwelling that fronts on such a highway, electrical and telecommunications services may be overhead on the municipal road and to the dwelling if one or more existing single family residential dwellings exist with overhead or above ground service on the block face for which the subdivision would be approved or the building permit issued. (Bylaw Nos. 1513 and 1555)
- 9.4. All utility services, junction boxes, transformers and service facilities shall be located within the road right of way or as approved by the Utility owner if not in the road right of way. (Bylaw No. 1494)
- 9.5. Every attempt shall be made to locate junction boxes, vaults and transformers in boulevard areas and not sidewalks. These should favour one side of the sidewalk and not be located in the middle of the sidewalk. If there are no alternatives, the services shall be installed at the edge of the sidewalk and shall have “non-slip” lids. No junction boxes or vaults are permitted when the road grade exceeds 4%. Utility lids must be surrounded by a 150mm thick by 150mm wide square concrete apron.
- 9.6. Deleted (Bylaw No. 1513)
- 9.7. Existing electrical transmission systems may remain overhead in the frontage of a new subdivision or development unless, in the opinion of the transmission service provider, the proximity of the proposed structures will be in conflict. (Bylaw No. 1513)
- 9.8. All new three phase transmission systems in the City Centre area as identified in the Official Community Plan shall be installed underground, unless otherwise permitted by the City Engineer.
- 9.9. Delete. (Bylaw No. 1669)

SCHEDULE 10 IRRIGATION STANDARDS

10. GENERAL

Furnish all labour, materials, equipment, permits and services necessary for the complete supply and installation of a properly operating irrigation system as indicated on the drawings and specified herein.

10.1. RELATED WORK

10.1.1. Unit Paving	Section 321401
10.1.2. Concrete Walks, Curbs And Gutters	Section 033020
10.1.3. Topsoil And Finish Grading	Section 329121
10.1.4. Seeding	Section 329220
10.1.5. Hydraulic Seeding	Section 329219
10.1.6. Sodding	Section 329223
10.1.7. Planting Of Trees, Shrubs And Groundcovers	Section 329301

10.2. QUALITY ASSURANCE

- 10.2.1. All irrigation designs for city approval must be designed by a certified irrigation designer – turf/commercial classification as certified by IIABC or IA.
- 10.2.2. Line voltage wire shall be CSA approved and follow the *Canadian Electrical Code (CEC)*. Line voltage wire must be installed by a certified electrician with the requisite qualifications.
- 10.2.3. The contractor shall install the irrigation system in accordance with all applicable plumbing regulations.
- 10.2.4. All irrigation components and installation to comply as a minimum to irrigation industry association of British Columbia (IIABC) – standards for landscape irrigation systems.
- 10.2.5. The Contractor shall be a member in good standing of the irrigation Industry Association of B.C. and have met the qualification standards currently applied to contractors by that organization.
- 10.2.6. The Developer is required to provide warranty for all irrigation equipment outlined in this specification and on irrigation drawing(s).

10.3. SUBMITTALS

10.3.1. Design and Record Drawings:

- 10.3.1.1. Design Drawings: Minimum 7 business days prior to scheduled work, the irrigation contractor will provide the City with a set of professionally designed and drafted irrigation documents at the same scale as the project design plans with a complete list of materials for review. Drawings will indicate all components, models, and materials from water supply to irrigation heads. All underground service information is to be clearly shown on design drawings.
- 10.3.1.2. Record Drawings: Upon completion, the irrigation contractor must submit 2 prints of digitally drawn as-built drawings. The prints will indicate the location of connection points, backflow preventers, sleeves, main lines, lateral lines, emitter lines, valves, controllers, and any other component installed. Dimensionally locate pressurized components and pressurized lines from buildings, curb lines or other fixed site features. Main lines, individual zones, and associated components to be drawn on separate layers. Copy of backflow test to be included.
- 10.3.1.3. Zone Map: Contractor to provide 2 laminated copies, in letter sized format, a zone map indicating type of zone (shrubs, trees, etc.), colour coded, general valve locations and valves keyed to controller station numbering. One copy is to be attached to inside of controller cabinet.
- 10.3.1.4. Record irrigation drawings must be submitted to and approved by the Director of Parks, Recreation and Facilities in “.dwg” and “.pdf” format.

10.4. OPERATING PRESSURE STANDARDS

- 10.4.1. Irrigation system to have a dynamic operating pressure between 50 and 90psi.
- 10.4.2. Irrigation systems to have a minimum 10psi residual pressure available while the critical station is operating.

10.5. MATERIALS

- 10.5.1. Plastic Pipe: Plastic pipe shall be rigid un-plasticized PVC. The pipe shall be homogeneous throughout and free from visible cracks, holes, foreign material, blisters, deleterious substances, wrinkles and dents, PVC 1120 conforming to requirements of CSA B137.3.
 - 10.5.1.1. Schedule 40 Polyvinyl–Chloride (PVC), for all pressurized lines and for hard surface sleeving. 150mm SDR 28 pipe may be used for irrigation sleeving. (Bylaw No. 1817)
 - 10.5.1.2. Class 200 Polyvinyl–Chloride (PVC), for all laterals.

10.5.2. Emitter line shall be used for the headers of all emitter lines. Tubing will conform to the requirements of CSA B137.1 and have a maximum pressure rating of 75 psi.

10.5.3. Automatic Control Valves

10.5.3.1. Heavy-duty, plastic, commercial grade electric remote-control valve, with flow control. Irritrol 100 series Century Plus series valves, or Rain Bird PGA valves must be used.

10.5.3.2. Irritrol Omni regulating module or Rain Bird PSR Dial Valve Pressure regulator must be used on all drip emitter line and hanging basket zones.

10.5.3.3. When zone flows are less than 5gpm, Irritrol 700-.75 valve must be used.

10.5.4. Control Valve Boxes

10.5.4.1. All control valves shall be installed in a rectangular thermoplastic valve access box of proper size as required for EASY ACCESS AND REPAIR to the valves. Access boxes shall be complete with approved thermoplastic cover and stainless steel bolt.

10.5.5. Sprinkler Heads (turf only)

10.5.5.1. Rotors: Toro T5P, or Rain Bird 5000, 3500 (Bylaw No. 1817)

10.5.5.2. 1" Rotors: Toro 640 Series or Rain Bird Falcon. Stainless steel only on all playfields.

10.5.5.3. Spray Heads: Rain Bird 1800 or Irritrol I-PRO spray* bodies.

10.5.5.4. Nozzles: Toro precision or Hunter MP-Rotator must be used.

10.5.6. Class 200 Polyvinyl–Chloride (PVC), for all laterals

10.5.7. Irrigation Controller:

10.5.7.1. Irritrol Total Control or as approved by the Parks Manager. (Bylaw No. 1817)

10.5.7.2. Controller cabinet: to be lockable aluminum, weather proof, hinge and hasped, mounted securely, minimum 600mm above finished grade. On all installations, the cabinet will be powder coated the same colour as the adjacent street light poles. Cabinet size must be sufficient to house the controller and duplex receptacle. Locks are to be supplied by the City.

10.5.7.3. Cabinet mounting: cabinet is to be mounted to 100mm square steel tubing – set in concrete base (min. 600mm depth), powder coated colour to match cabinet. Location of post to be 900mm from sidewalk, 3m min. away from intersections and preferably within shrub beds.

- 10.5.7.4. If it is the opinion of the City Parks Manager that a controller cabinet is impractical, the controller may be housed in an approved access box.
- 10.5.8. Wire:
 - 10.5.8.1. Control: single strand copper wire TWU-40 #14 gauge. Control wire to be any colour except white.
 - 10.5.8.2. Common: single strand copper wire TWU-40 312 gauge. Common wire to be white in colour.
- 10.5.9. Subsurface drip emitter line:
 - 10.5.9.1. DL2000 (RGP-412) c/w Root guard, with red stripe. Manufacturer, Toro -3.8 Lph, 300mm emitter spacing.
 - 10.5.9.2. Toro Air Relief Valve (YD-500-34) or approved equivalent.
 - 10.5.9.3. Toro DL2000 Flush Valve (FCH-H-FIPT) or approved equivalent.
 - 10.5.9.4. Toro DL2000 Steel-Soil Staple (SSS-50) or approved equivalent.
- 10.5.10. Pressure regulating module: see Automatic Control Valves.
- 10.5.11. Primer and Glue
 - 10.5.11.1. WELD-ON P70 primer must be used when gluing pipe. (Bylaw No. 1817)
 - 10.5.11.2. WELD-ON 705 PVC glue must be used after primer. (Bylaw No. 1817)
- 10.5.12. Miscellaneous:
 - 10.5.12.1. Disc Filter: 38mm super 80 mesh Arkal disc filter. Unless system has greater than 500 lineal meters of drip emitter line, then a 50mm Dual HP 80 mesh, Arkal disc filter is required.
 - 10.5.12.2. Hose connections: brass, 19mm male thread.
 - 10.5.12.3. Battery operated timer: Toro DDCWP (2-4-6-8 zones) or as approved by Parks Manager. (Bylaw No. 1817)
 - 10.5.12.4. Swing Joint Assembly Fabricated with three (3) threaded Schedule 40 PVC elbows and one (1) threaded Schedule 80 PVC nipple. Minimum 6" nipple for sprays and medium Rotors. Minimum 10" nipple for 1" Rotors.
 - 10.5.12.5. Backflow Prevention Assembly: Watt Series 007 Double Check Valve Assemblies.

- 10.5.13 Main line shall be Schedule 40 PVC installed a minimum of 450mm below grade to top of pipe in all areas. Mainline shall be minimum of 50mm or as specified by the Director of Parks, Recreation and Facilities. All mainlines and lateral lines under hard surface areas shall have Schedule 40 PVC sleeves unless required otherwise by the Director of Parks, Recreation and Facilities.

10.6. GENERAL INSTALLATION

- 10.6.1. Obtain and pay for all permits, fees and taxes associated with the installation and operation of complete irrigation systems.
- 10.6.2. Separate zones are required for turf, trees, shrubs, annuals, and hanging baskets.
- 10.6.3. Valve manifolds are encouraged to be centrally located with as many valves on one (1) manifold as possible. Valves are to be attached to piping with SCH80 UNIONS at both the inlet and outlet of each valve. Valves are not to touch each other or the valve box sides. Valve boxes are to be supported with one (1) brick in each corner. Minimum distance to lid 100mm. Minimum 6" of clean pea gravel under manifolds wrapped in landscape cloth to protect from dirt. All wire connections must be properly waterproofed and a minimum 30" expansion coil left in the box. Wires should be neatly coiled so as not to interfere with maintenance. See Details P1-P15 for complete installation requirements.
- 10.6.4. The Contractor shall obtain all underground service information and shall be solely responsible to locate all existing services in the vicinity, prior to commencing work.
- 10.6.5. Primer to be used on all pipe connections.
- 10.6.6. Wires are to be buried in a common trench strapped/ secured to underside of mainline.
- 10.6.7. Lateral lines shall be installed a minimum of 300mm below grade to top of pipe in all soft landscape areas.
- 10.6.8. All piping within sports fields shall be installed a minimum of 450mm below grade to top of pipe.
- 10.6.9. Subsurface drip emitter line is to be installed 100mm below surface of growing medium. Perimeter emitter drip line to be minimum 2" to maximum 4" from perimeter area. Secure emitter drip line with minimum 6" wire staples every 4'-6' and at all fittings (tees, elbows etc.). Emitter line shall be used for the footers of all emitter lines. See Detail P1- P15 for complete installation requirements.
- 10.6.10. All piping shall be flushed prior to installation of subsurface drip emitter line.
- 10.6.11. Installation location of controller as approved by City of Langford.

- 10.6.12. All mainline piping shall be bedded in sand, sand depth to be 50mm on top and bottom of pipe. Laterals to be bedded in backfill material free from rocks and other unsuitable materials which could damage the pipe or create unusual settling problems.
- 10.6.13. All sprinklers shall be installed on swing joints using PVC 90-degree street elbows and PVC Schedule 80 nipples, no Marlex fittings permitted. Rain Bird prefabricated swing arms allowed on temporary systems only. When using 12" popups use swing joints on the bottom inlet only.
- 10.6.14. When using precision nozzles, elevate heads ½" in turf and 1" in beds to eliminate back siphonage of debris. Do not install below soil or mulch level.
- 10.6.15. Sprinklers shall be installed a maximum of 25mm away from any retaining wall, sidewalk or solid boundary. Curb locations are preferred.
- 10.6.16. All trees will have two emitter loops per tree as follows: (1) 1.82m diameter emitter loop and (1) 0.9m diameter emitter loop per tree, annual plantings will have a 350mm spacing for groundcover and a 450mm emitter line spacing for shrubs.
- 10.6.17. Flow rates through meters, backflow prevention devices and valves shall not exceed manufacturer specifications.
- 10.6.18. All emitter line ends to terminate into a Polyethylene header or footer to create a looped subsystem. Emitter run lengths not to exceed manufacturers recommended distances.
- 10.6.19. Each emitter zone to have a drain valve installed. Drain valve to be located at low point of emitter zone, installed in a polyethylene tubing footer. Install a 6" round valve box; 50mm from lid. Minimum 1 for every 10gpm. See details P1-P15 for complete installation requirements.
- 10.6.20. Each emitter zone to have a vacuum release valve installed. Vacuum release valve to be located at the high point of emitter zone (installed in 6" round valve box; 50mm from the lid). Minimum 1 for every 10gpm. See details P1- P15 for complete installation requirements.
- 10.6.21. Drain valve and air vacuum release valve to be accessible inside a lockable 152mm round valve box.
- 10.6.22. All beds to have drip emitter line and to be separately zoned from turf. Trees located in beds already watered with drip emitter line do not require a separate zone.
- 10.6.23. Hanging basket irrigation zones will include a separate shut off for each pole located adjacent the pole base in a 150mm round valve box.
- 10.6.24. Hanging basket irrigation zones will include a minimum 19mm horizontal supply line. The lamp standard will be supplied with a 12.5mm vertical line running inside the

pole. 6mm polyethylene tubing is to be installed up to the hanging basket bracket through a nylon grommet. A suitable grommet must be installed to protect the tubing from wear.

- 10.6.25. All backflow devices shall be installed with SCH80 unions at the inlet and outlet. Immediately downstream of the device a 19mm hose-bib shall be installed for winterizing. The backflow device test certificate must be submitted to the Parks Department upon completion. See details P1-P15 for complete installation requirements.
- 10.6.26. All disc filters shall be installed with SCH80 unions at the inlet and outlet as well as isolation valves to assist with cleaning. See details P1-P15 for complete installation requirements.
- 10.6.27. All capped main line pipes are to include a hose-bib in a lockable valve box to ensure lines can be cleared out before Winter. Wire for future extension to be neatly coiled with a minimum 30" length. See details P1-P15 for complete installation requirements.
- 10.6.28. Irrigation sleeve diameter to be a minimum 150mm or twice the diameter of main or lateral line running through it, whichever is greater.

10.7. CLEANUP & INSPECTION

- 10.7.1. Any damage to paving, planting or any other structure due to settlement of improperly compacted trenches shall be promptly repaired at the contractor's expense to the satisfaction of the City of Langford.
- 10.7.2. Surplus material shall become property of the contractor and removed from site.
- 10.7.3. All irrigation systems will require inspections by the Director of Parks, Recreation and Facilities or a City of Langford staff member as designated by the Director of Parks, Recreation and Facilities with 2 business day notice according to the following table 10-1:

TABLE 10-1: Inspection Requirements

1st Inspection	Sleeving
2nd Inspection	Open Trench Main Line & Pressure Test
3rd Inspection	Open Trench Lateral Line
4th Inspection	Irrigation System, Controller & Coverage Test

- 10.7.4. The Contractor shall balance and adjust the various components of the irrigation system to ensure the efficient operation of the system. This includes the adjustment of pressure regulators, part circle sprinklers and individual adjustments of the controllers. Also make minor changes in sprinkler head locations to provide full coverage as part of work.

10.8. GUARANTEE

10.8.1. Provide a written guarantee for all workmanship and materials for one year from the date of Substantial Completion as certified by the Project Administrator.

10.9. Irrigation shall be installed in the following boulevards within the City of Langford:

- Bear Mountain Parkway
- Goldstream Avenue
- Happy Valley Road
- Jacklin Road
- Langford Parkway
- Millstream Road
- Sooke Road
- Veterans Memorial Parkway
- Westshore Parkway
- City Park Frontages
- All areas within the City Center
- All tree locations in new boulevards (Bylaw No. 1817)

SCHEDULE 11 – SUPPLEMENTS TO MMCD
SUPPLEMENTARY SPECIFICATIONS MODIFICATIONS
AND
ADDITIONS TO THE MMCD SPECIFICATIONS

CITY OF LANGFORD		
SUPPLEMENTARY SPECIFICATIONS		
SECTION	PARAGRAPH	TITLE
01 53 01 – Temporary Facilities		
31 23 17 – Rock Removal	1.6	Measurement for Payment
	1.7	Seismic Survey and Monitoring
	1.8	Inspection and Testing
32 11 23 – Granular Base	1.4.4	Measurement for Payment
03 30 20 – Concrete Walks, Curbs and Gutters	3.10	Control Joints
33 11 01 – Waterworks	2.0	Products
	3.0	Execution
33 40 01 – Storm Sewers	3.11.6	Cleaning and Flushing
	3.12	Inspection and Testing
33 30 01 – Sanitary Sewers	3.11.6	Cleaning and Flushing
	3.12	Leakage Testing – General
	3.18	Video Inspection
33 34 01 – Sewage Force Mmains	3.14.4	Cleaning and Flushing

CITY OF LANGFORD

SUPPLEMENTARY SPECIFICATIONS

SECTION	SUB SECTION	TITLE	SUPPLEMENTARY SPECIFICATIONS
01 53 01 – Temporary Facilities			Delete This Section
31 23 17 – Rock Removal	1.6	Measurement for Payment	Add Clause 1.6.6 which reads: “Payment for trench rock will be by cubic metre. For measurement purposes, the volume of trench rock is defined as that amount below subgrade in areas of mass rock removal or below natural rock surface, extending down to 200 mm below the lowest designed pipe or service invert in the trench and having a width of 450 mm plus the overall external diameter or dimension of the service or services being installed. For two services in common trench this means the width of the two outside diameters, plus the separation between the pipes plus 450 mm. Payment for the excavation of structures shall extend 500 mm from the outside faces of the structure and shall extend to 200 mm below the lowest elevation of the structure.
31 23 17 – Rock Removal	1.7	Seismic Survey and Monitoring	In Paragraph 1.7.1 replace the Phrase “Contract Administrator” with “Contractor”. In Paragraph 1.7.2 replace the word “Owner” with the word “Contractor”.
32 11 23 - Granular Base	1.4	Measurement for Payment	Revise Paragraph 1.4.1 to read: “Limit for payment to be to the face of curb as shown on the Standard Detail Drawings.”
03 30 20 - Concrete Walks, Curbs and Gutters	3.10	Control Joints	Revise Paragraph 3.10.1 to read: “In sidewalks only, “Zip strip” to be installed as control joints at maximum 3 m intervals.”
33 11 01 - Waterworks	2.0	Products	Delete these sections and replace with (C.R.D. Water Department) Engineering Specifications and Standard Drawings.

CITY OF LANGFORD

SUPPLEMENTARY SPECIFICATIONS

SECTION	SUB SECTION	TITLE	SUPPLEMENTARY SPECIFICATIONS
33 40 01 – Storm Sewers	3.10	Service Connection Installation	Delete the first 2 words of “Where specified,” from Paragraph 3.10.3 to read “Install inspection chambers at, etc.”
	3.11	Cleaning and Flushing	Revise Paragraph 3.11.6 to read: “Remove foreign material from pipe and related appurtenances by power flushing with water.” Delete the remainder of the Paragraph.
	3.12	Inspection and Testing	In 3.12.1 replace the phrase “under 900mm in diameter.” with “prior to Acceptance of Works and services and prior to Final Acceptance of works and services.” Add Clause 3.12.4 which reads: “The Contractor shall carry out power flushing and video inspection of all storm sewers. The results of the inspection shall be delivered to the Contract Administrator at least 14 days prior Acceptance of Works and services and prior to Final Acceptance of works and services. Inspection records shall illustrate flow through the pipe for all design grades less than 2%. Add Clause 3.12.5 which reads: “The inspection record shall be in a form acceptable to the City.” Add Clause 3.12.6 which reads: “Inspection video shall be submitted to the City in electronic format.”
33 30 01 - Sanitary Sewers	3.11	Cleaning and Flushing	Revise 3.11.6 to read: “Remove foreign material from pipe and related appurtenances by power flushing with water.” Delete the remainder of the paragraph.
	3.12	Leakage Testing General	The preferred method of leakage testing is the low pressure air test. All other tests will be carried out at the discretion of the Contract Administrator.
	3.18	Video Inspection	Revise Paragraph 3.18.1 replace the phrase “under 900mm in diameter following completion of installation with “prior to Acceptance of Works and services and prior to Final Acceptance of works and services.”

CITY OF LANGFORD

SUPPLEMENTARY SPECIFICATIONS

SECTION	SUB SECTION	TITLE	SUPPLEMENTARY SPECIFICATIONS
			<p>Add Clause 3.18.3 which reads: "Inspection records shall illustrate flow through the pipe for all design grades less than 2%."</p> <p>Add Clause 3.18.4 which reads: "The inspection report shall be in a form acceptable to the City."</p> <p>Add Clause 3.18.5 which reads: "Inspections shall be submitted to the City in electronic format."</p> <p>Add Clause 3.18.6 which reads: "Prior to the end of the maintenance period, or when directed by the Contract Administrator, the Contractor is to carry out power flushing and video inspection of all mains. The results of the inspection are to be delivered to the Contract Administrator at least 14 days prior to the end of the maintenance period."</p>
33 34 01 - Sewage Force Mains	3.14	Cleaning and Flushing	Revise Paragraph 3.14.4 to read: "Remove foreign material from pipe and related appurtenances by mandrelling or swabbing."

**SUPPLEMENTARY SPECIFICATIONS MODIFICATIONS
AND ADDITIONS TO THE MMCD SPECIFICATIONS**

DRAWING NO.	TITLE	SUPPLEMENT
B1	Banner Sizes	Add this drawing (Bylaw 1669)
C1	Concrete Sidewalk, Infill and Barrier Curb	Delete this drawing (Bylaw 1000)
C2	Concrete Sidewalk and Barrier Curb	Delete this drawing (Bylaw 1000)
C3	Concrete Sidewalk and Rollover Curb	Delete this drawing (Bylaw 1000)
C6	Concrete Median Curb and Interim Curbs	Delete this drawing and refer to Drawing No. SS C6 "Curb and Gutter Detail". (Bylaw 1000)
C8	Wheelchair Ramp for Sidewalk, Infill and Barrier Curb	Delete this drawing and refer to Drawing No. SSC8, titled "Sidewalk Ramp (Boulevard Adjacent to Curb)". (Bylaw 1000)
C9	Wheelchair Ramp for Sidewalk and Barrier Curbs	Delete this drawing and refer to Drawing No. SSC9, titled "Sidewalk Ramp (Sidewalk Adjacent to Curb)". (Bylaw 1000)
C15	Driveway Configurations	Replace drawing C15 with new C15 (Bylaw 1574)
E1	Double Headed Streetlight	Add this drawing (Bylaw 1000)
E2	Single Head Lumca Prestige	Replace with new E2 (Bylaw 2103)
E3	Cyclone Streetlight	Replaced with drawing E8 (Bylaw 1618)
E4	Cyclone Streetlight Base	Replaced with drawing E9 (Bylaw 1618)
E5	Landscaping Outlet Post	Add this drawing (Bylaw 1000)
E6	Waste Receptacle Kiosk	Add this drawing (Bylaw 1000)
E7	Cobra Street Light	Replaced with drawing E10 (Bylaw 1618)
E8	Langford Post Top Luminaire	Amend this drawing (Bylaw 1669)
E9	Langford Post Top Luminaire Service Base	Added Bylaw 1618
E10	Cobra Street Lighting	Amend this drawing (Bylaw 1669)
G1	General Legend for Contract Drawings	Delete this drawing and refer to Contract Drawing Legends. (Bylaw 1000)
G2	Legends for Materials	Delete this drawing. (Bylaw 1000)
G3	Legend for Streetlight and Traffic Signal Drawings	Delete this drawing and refer to Contract Drawing Legends. (Bylaw 1000)
G4	Utility Trench	Amend this drawing (Bylaw 1817)
G5	Pavement Restoration	Amend this drawing (Bylaw 1817)
L1	Street Tree Planting Detail	Replace with drawing L1(a) (Bylaw 2103)
L2(a)	Tree Grate Planting Detail	Replace with new L2(a) (Bylaw 2103)
L2(b)	Tree Grate Planting Detail	Replace with new L2(b) (Bylaw 2103)
L2(c)	Tree Grate Installation Detail	Replace with new L2(c) (Bylaw 2103)
L2(d)	Tree Grate Installation Detail	Replace with new L2(d) (Bylaw 2103)
L2(e)	Tree Grate Detail Specification	Replace with new L2(e) (Bylaw 2103)

DRAWING NO.	TITLE	SUPPLEMENT
L2(fa)	Artificial Turf Installation at Boulevard Tree	Replace drawing L2(f) with L2(fa) (Bylaw 1817)
L2(fb)	Artificial Turf Installation at Boulevard Tree	Add this drawing (Bylaw 1817)
L2(g)	Artificial Turf at Concrete	Amend this drawing (Bylaw 1817)
L3(c)	Artificial Turf Detail	Add this drawing (Bylaw 2103)
L4(a)	Median Planting Detail	Add this drawing (Bylaw 2103)
L4(b)	Median Planting Detail	Add this drawing (Bylaw 2103)
L6(a)	Sod Installation Detail	Add this drawing (Bylaw 2103)
L6(b)	Seed Installation Detail	Add this drawing (Bylaw 2103)
L7	Split Rail Fence Detail	Add this drawing (Bylaw 2103)
P1	Municipal Irrigation Sleeving Detail	Replace with new P1 (Bylaw 2103)
P2	Municipal Irrigation Sleeving Detail	Replace with new P2 (Bylaw 2103)
P3	Municipal Irrigation Sleeving Detail	Replace with new P3 (Bylaw 2103)
P4	Municipal Irrigation Sleeving Detail	Replace with new P4 (Bylaw 2103)
P5	Water Connection	Replaced with new P5 (Bylaw 1292)
P5(a)	Irrigation Detail	Add this drawing (Bylaw 2103)
P5(b)	Irrigation Detail	Add this drawing (Bylaw 2103)
P6	Valve Manifold	Add this drawing (Bylaw 1000)
P6(a)	Irrigation Detail	Add this drawing (Bylaw 2103)
P7	Drip Line	Replace with new P7 (Bylaw 1292)
P8(a)	Irrigation Detail	Add this drawing (Bylaw 2103)
P8(b)	Irrigation Detail	Add this drawing (Bylaw 2103)
P9	Irrigation Detail	Add this drawing (Bylaw 2103)
P10	Irrigation Detail	Add this drawing (Bylaw 2103)
P11	Irrigation Detail	Add this drawing (Bylaw 2103)
P12	Irrigation Detail	Add this drawing (Bylaw 2103)
P13	Irrigation Detail	Add this drawing (Bylaw 2103)
P14	Irrigation Detail	Add this drawing (Bylaw 2103)
P15	Irrigation Detail	Add this drawing (Bylaw 2103)
RS1	Turn Around Details	Amend this drawing (Bylaw 1817)
RS2	Turn Arounds	Amend this drawing (Bylaw 1817)
RS3	Temporary Turn Arounds	Add this drawing (Bylaw 1000)
RS4	Pedestrian Activated Crosswalk Signals	Replace with new RS4 (Bylaw 2103)
RS5	Canada Post Mailbox Pull Out	Replace with new RS5 (Bylaw 2103)
S4	Inside Drop Manhole	Delete this drawing (Bylaw 1000)
S6	Sewer Cleanout	Delete this Drawing and refer to Drawing No. SSS6 "Sewer Cleanout". (Bylaw 1000)
S9	Inspection Chamber for 100 to 200 Sanitary Sewer Connection	Amend this drawing (Bylaw 1817)
S10	Double Catch Basin	Add this drawing (Bylaw 1494)
S11	Top Inlet Catch Basin	Amend this Drawing (Bylaw 1669)

DRAWING NO.	TITLE	SUPPLEMENT
S15	Driveway Culvert with Concrete Block Endwalls	Delete this drawing (Bylaw 1817)
S16	Ditch Inlet	Add this Drawing to Standard Detail Drawings under "Storm and Sanitary Sewers" (Bylaw 1000)
S17	Sanitary Force Main Connection	Add this drawing (Bylaw 1000)
SD1	Stormwater Control and Treatment Areas	Add this drawing (Bylaw 1000)
SD2	Drainage Calculation Sheet	Add this drawing (Bylaw 1000)
SD3	Langford Rainfall Intensity-Duration Frequency Curve	Add this drawing (Bylaw 1000)
SD4	Lot Development Erosion and Sediment Control	Add this drawing (Bylaw 1000)
SD5	Silt Fence	Add this drawing (Bylaw 1000)
SD6	Sediment Basin	Add this drawing (Bylaw 1000)
SD7	Vertical Seepage Pit Detail	Replace with new SD7 (Bylaw 2103)
SD8	Combined Constructed Wetland and Detention Facility	Add this drawing (Bylaw 1000)
SD9	Grass Swale	Add this drawing (Bylaw 1000)
SD10	Filter Strip	Add this drawing (Bylaw 1000)
SD11	Oil/Grit Separator Chamber with External High Flow Bypass	Add this drawing (Bylaw 1000)
SD12	Oil/Grit Separator Type 1	Add this drawing (Bylaw 1000)
SD13	Oil/Grit Separator Type 2	Add this drawing (Bylaw 1000)
SD14	Flow Control Manhole	Add this drawing (Bylaw 1000)
SD15	Combined Detention for 2 Year Control & Oil/Grit Separator	Add this drawing (Bylaw 1000)
SD16	Storage and Outlet Sizing	Add this drawing (Bylaw 1000)
W1	Fire Hydrant Clearance Specifications	Add this drawing (Bylaw 1513)

LARGE BANNER

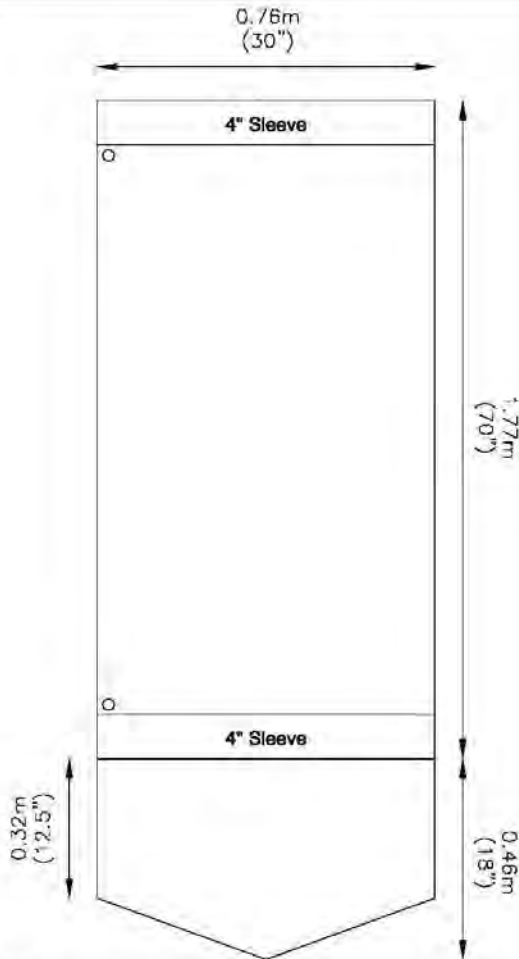

- NOTE:**
1. BANNER AND TAIL MATERIAL - DUO-FLEX BLOCK-OUT, WEIGHT 18oz.
 2. REINFORCE ALL EDGES WITH NYLON WEBBING.
 3. EXTRA MESH FABRIC REINFORCED POCKETS.
 4. MAY REQUIRE BLOCKOUT DEPENDING ON GRAPHICS.

SMALL BANNER

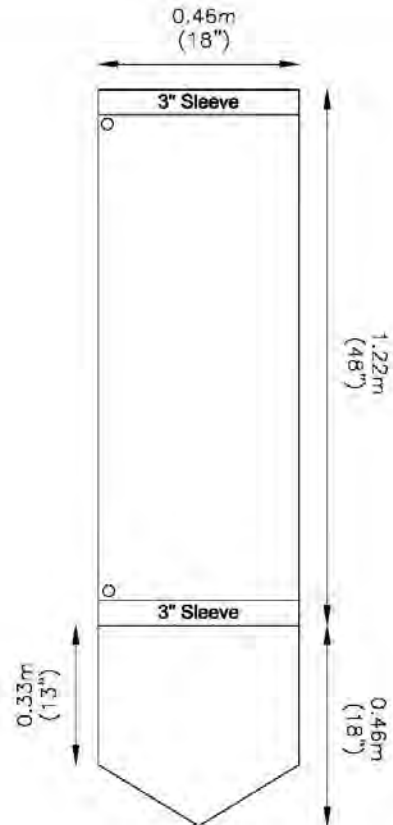

- NOTE:**
1. BANNER AND TAIL MATERIAL - CLOTH.
 2. DOUBLE STITCH ALL EDGES.
 3. WILL REQUIRE BLOCKOUT DEPENDING ON GRAPHICS.

BANNER SIZES



CITY OF LANGFORD
ENGINEERING DEPARTMENT

DATE: 30-Jan-17	DRAWN: MB	DWG No. B1
SCALE: NTS	APPROVED: GH	

Last Revised: Bylaw 1669, February 2017

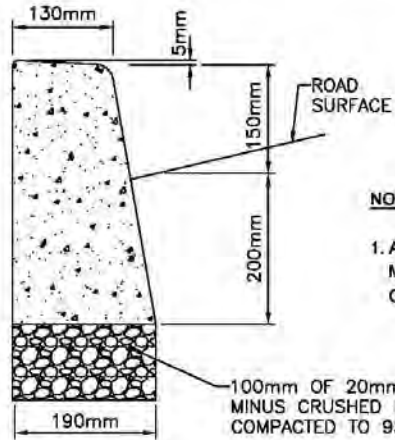

NOTES:

- 1. ALL CONSTRUCTION TO CONFORM TO MMCD SPECIFICATIONS AND CITY OF LANGFORD SUPPLEMENTS.

BARRIER CURB

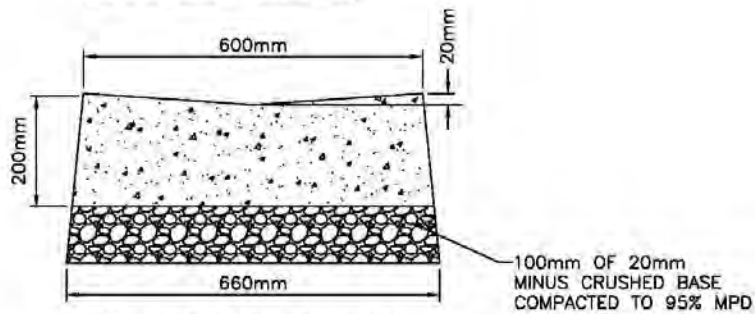

INVERTED GUTTER

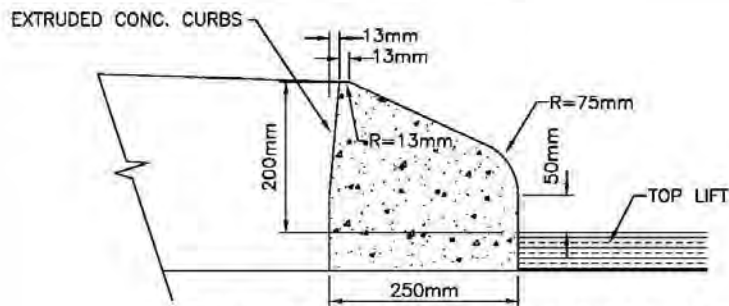

EXTRUDED CONCRETE CURB (ISLANDS)

**CURB AND GUTTER
DETAIL**



**CITY OF LANGFORD
ENGINEERING DEPARTMENT**

DATE:
2003/09/19

DRAWN:
SRC

SCALE:
NTS

APPROVED:

**MMCD SS
C6**

Last Revised: Oct 29, 2009

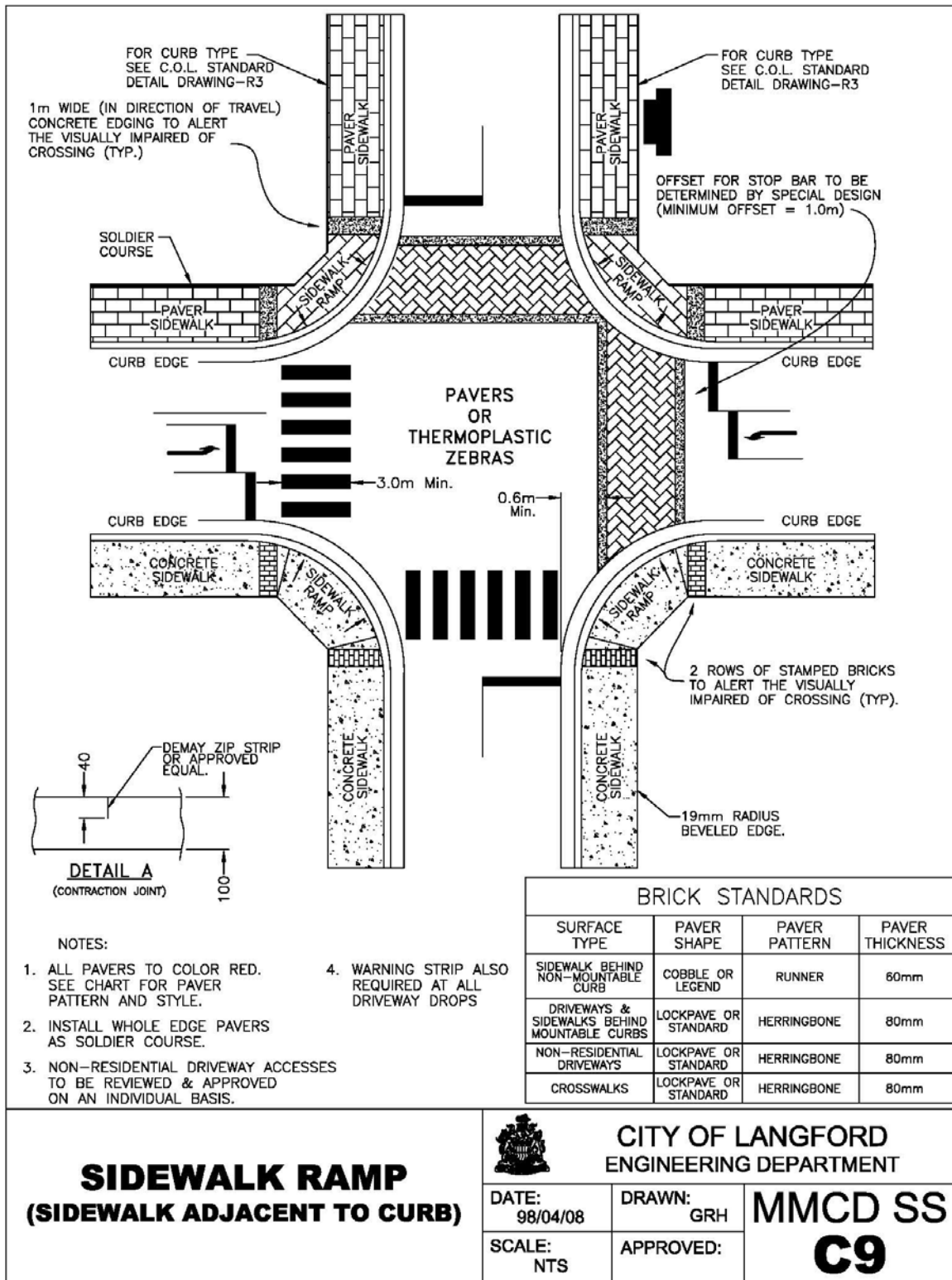

ADJACENT TO CURB

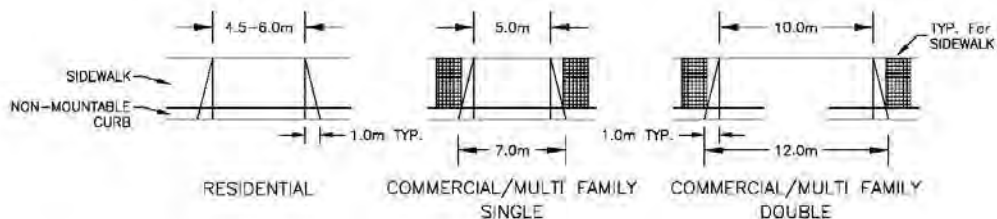

ADJACENT TO BOULEVARD

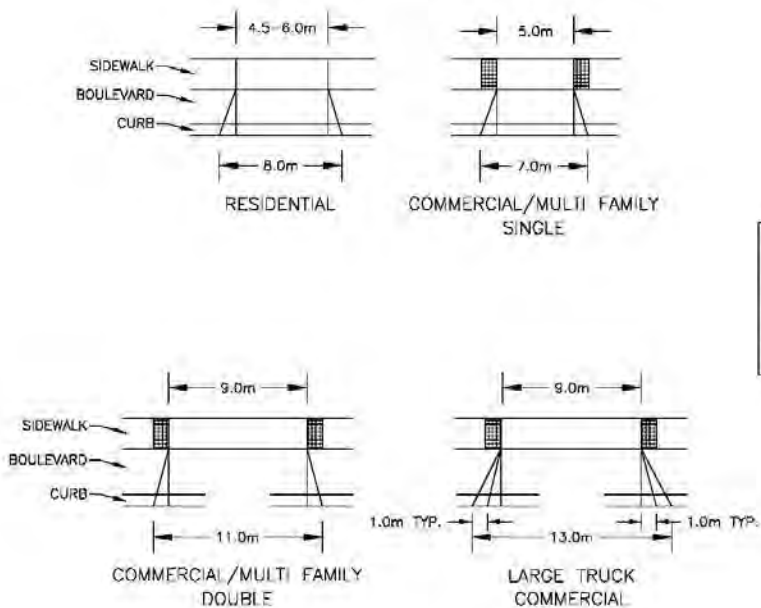

***NOTES:**
FLARES ONLY
REQUIRED WITH
NON-MOUNTABLE
CURB.

DRIVEWAY CONFIGURATIONS



CITY OF LANGFORD
ENGINEERING DEPARTMENT

DATE: 07-MAY-15	DRAWN: TWB	DWG No.
SCALE: NTS	APPROVED: MM	C15

Last Revised: May 19, 2015

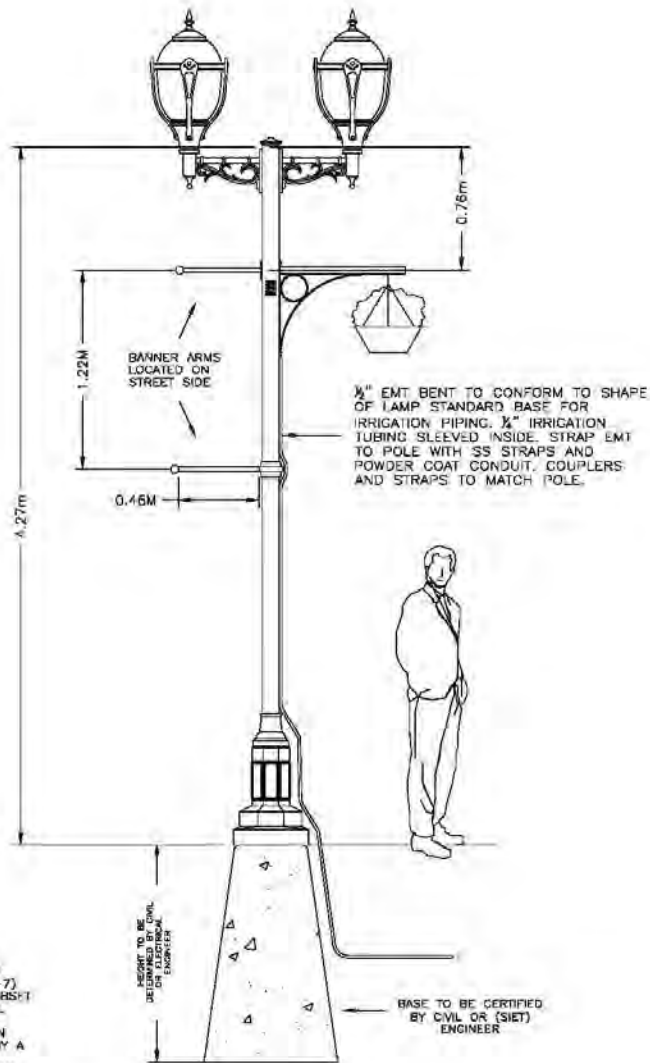

NOTES:

1. ALL POLES & HARDWARE SHALL BE POWDER COATED BURGUNDY MAROON (RAL 3007 OR DURACOAT #P-6196-7)
2. INTERNAL IRRIGATION ACCEPTABLE SUBJECT TO PROVINCIAL ELECTRICAL APPROVAL
3. ALL CONCRETE BASES SHALL BE IN ACCORDANCE WITH MMCD, POURED IN PLACE BASES SHALL BE CERTIFIED BY A PROFESSIONAL ENGINEER
4. IRRIGATION LINES CAN GO INSIDE LIGHT STANDARDS UPON APPROVAL BY THE ELECTRICAL INSPECTOR

**DOUBLE HEAD
LUMCA PRESTIGE**



**CITY OF LANGFORD
ENGINEERING DEPARTMENT**

DATE: 22-Jul-09

DRAWN: SE

DWG No.

SCALE: NTS

APPROVED:

E1

Last Revised: Nov 17, 2009

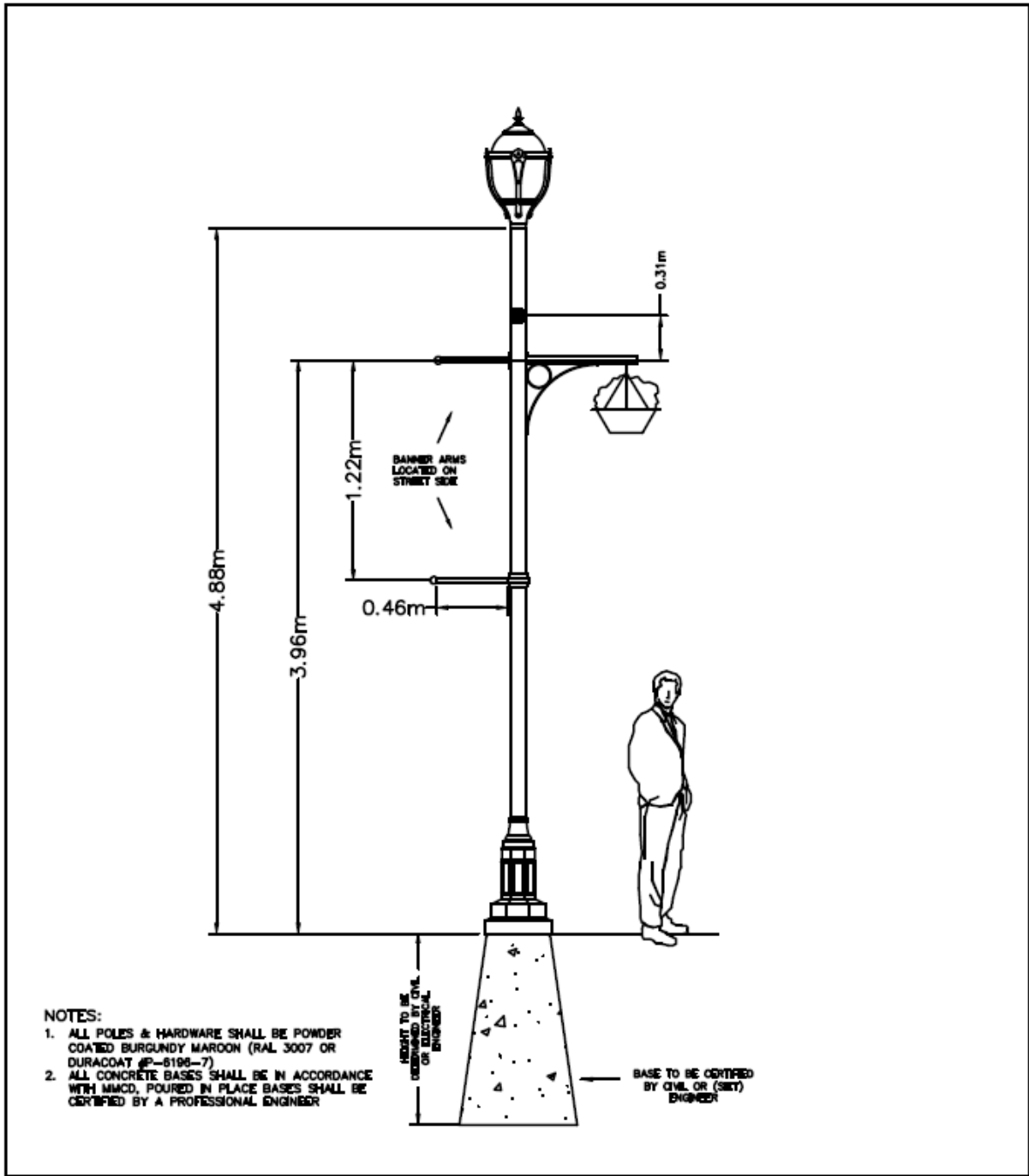

<h2>SINGLE HEAD LUMCA PRESTIGE</h2>	 CITY OF LANGFORD ENGINEERING DEPARTMENT		
	DATE: JULY 22 2009	DRAWN: SE	DWG No.
	SCALE: NTS	APPROVED:	E2

Last Revised: MAY 29, 2023

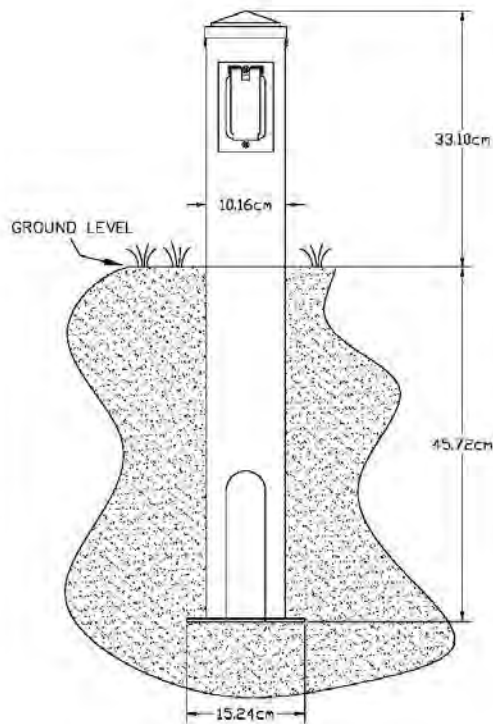

FRONT VIEW

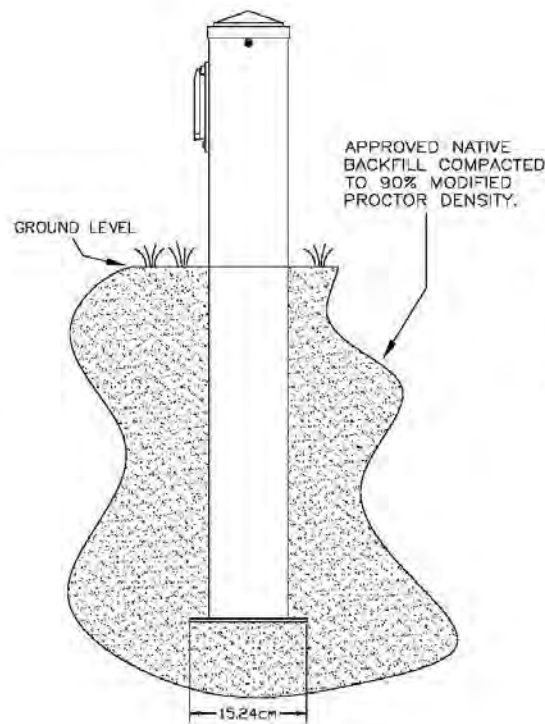

SIDE VIEW

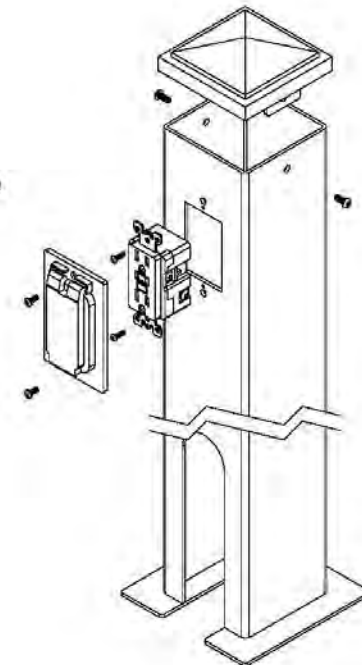

ISOMETRIC VIEW

NOTES:

1. ALL HARDWARE SHALL BE POWDER COATED

**LANDSCAPING OUTLET
ALUMINUM POST
DUPLEX GFI OUTLET**



**CITY OF LANGFORD
ENGINEERING DEPARTMENT**

DATE:
01-Apr-09

DRAWN:
JS

DWG No.

SCALE:
NTS

APPROVED:

E5

Last Revised: Nov 12, 2009

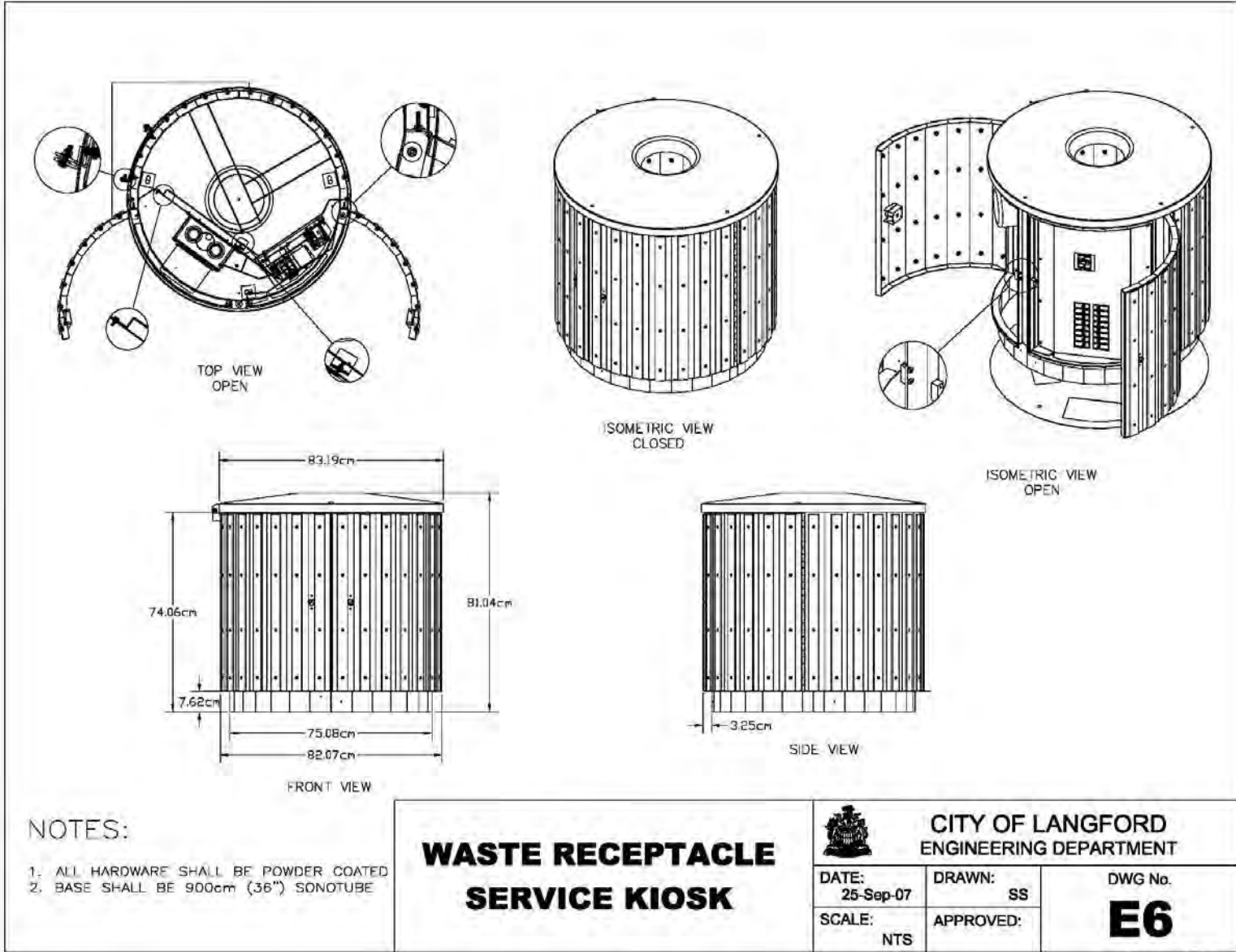

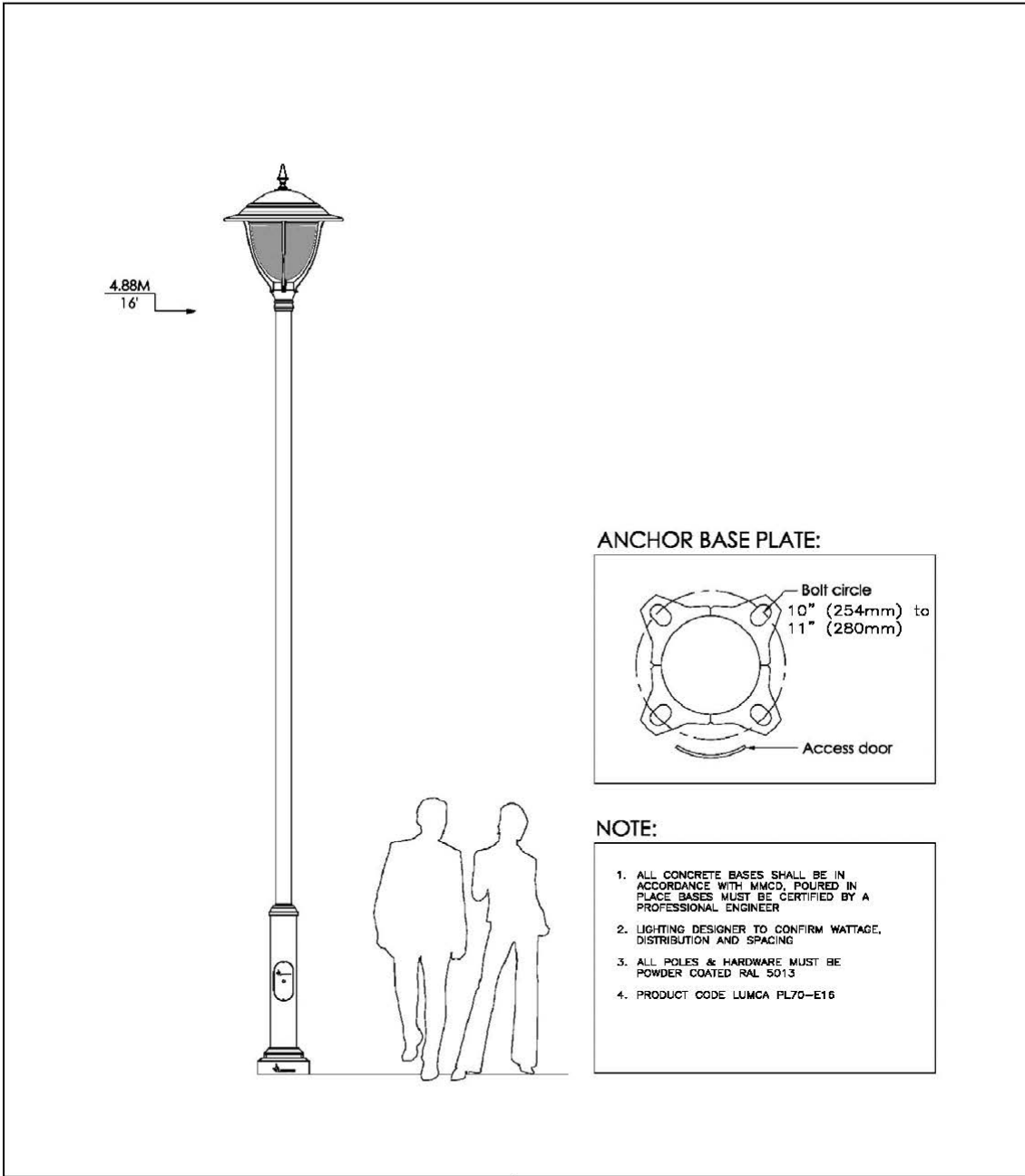

**LANGFORD
POST TOP LUMINAIRE**



**CITY OF LANGFORD
ENGINEERING DEPARTMENT**

DATE: 15-Mar-16	DRAWN:	DWG No. E8
SCALE: NTS	APPROVED: MM	

Last Revised: Bylaw 1669, February 2017

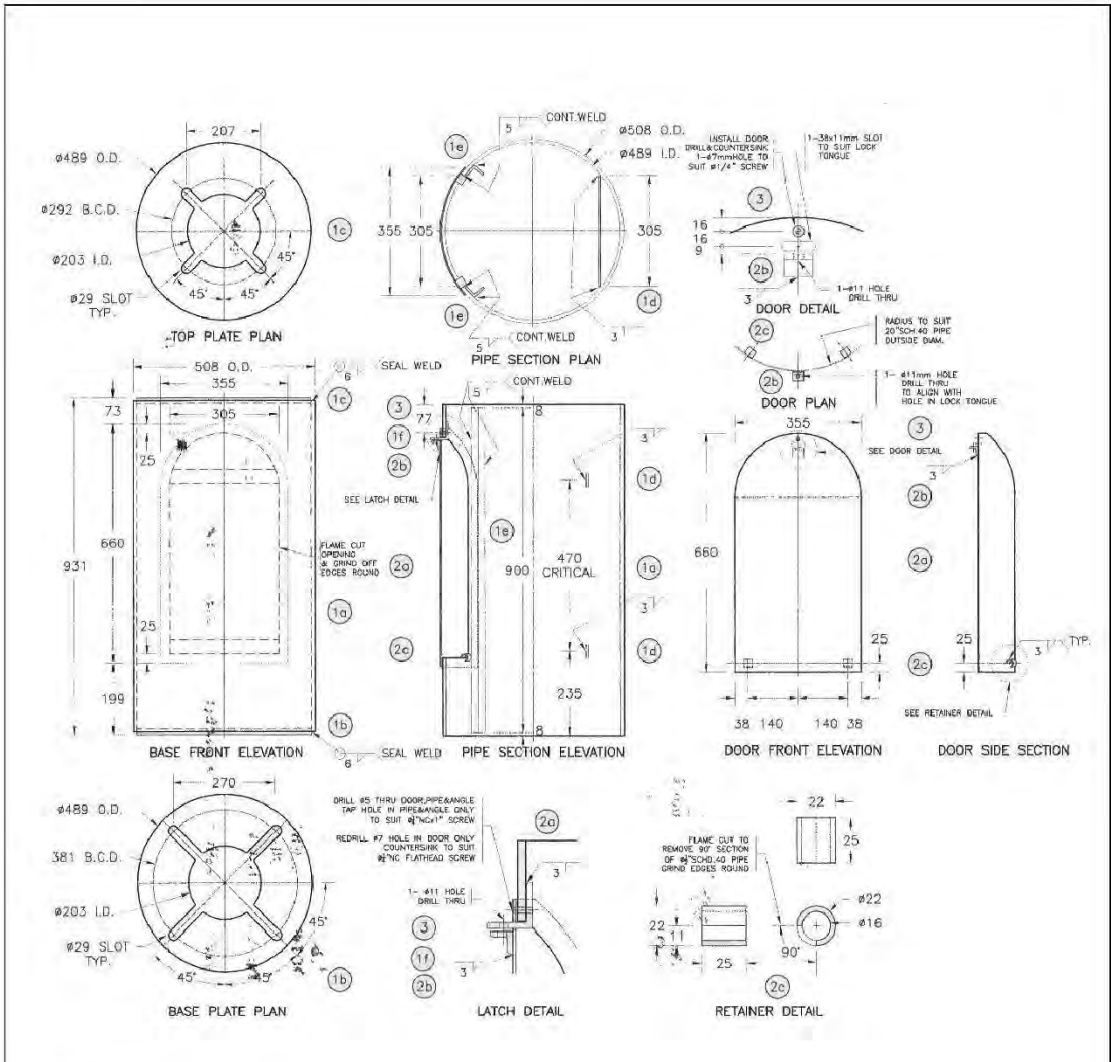

- NOTES:
1. ALL CONCRETE BASES SHALL BE IN ACCORDANCE WITH MMCD, POURED IN PLACE BASES MUST BE CERTIFIED BY A PROFESSIONAL ENGINEER
 2. ALL POLES & HARDWARE MUST BE POWDER COATED RAL 5013
 3. PRODUCT CODE NOVA POLE DTB 36

<h1>LANGFORD POST TOP LUMINAIRE SERVICE BASE</h1>	 <h2>CITY OF LANGFORD ENGINEERING DEPARTMENT</h2>		DATE: 15-Mar-16	DRAWN:	DWG No. E9
	SCALE: NTS	APPROVED: GH			

Last Revised: March 15, 2016

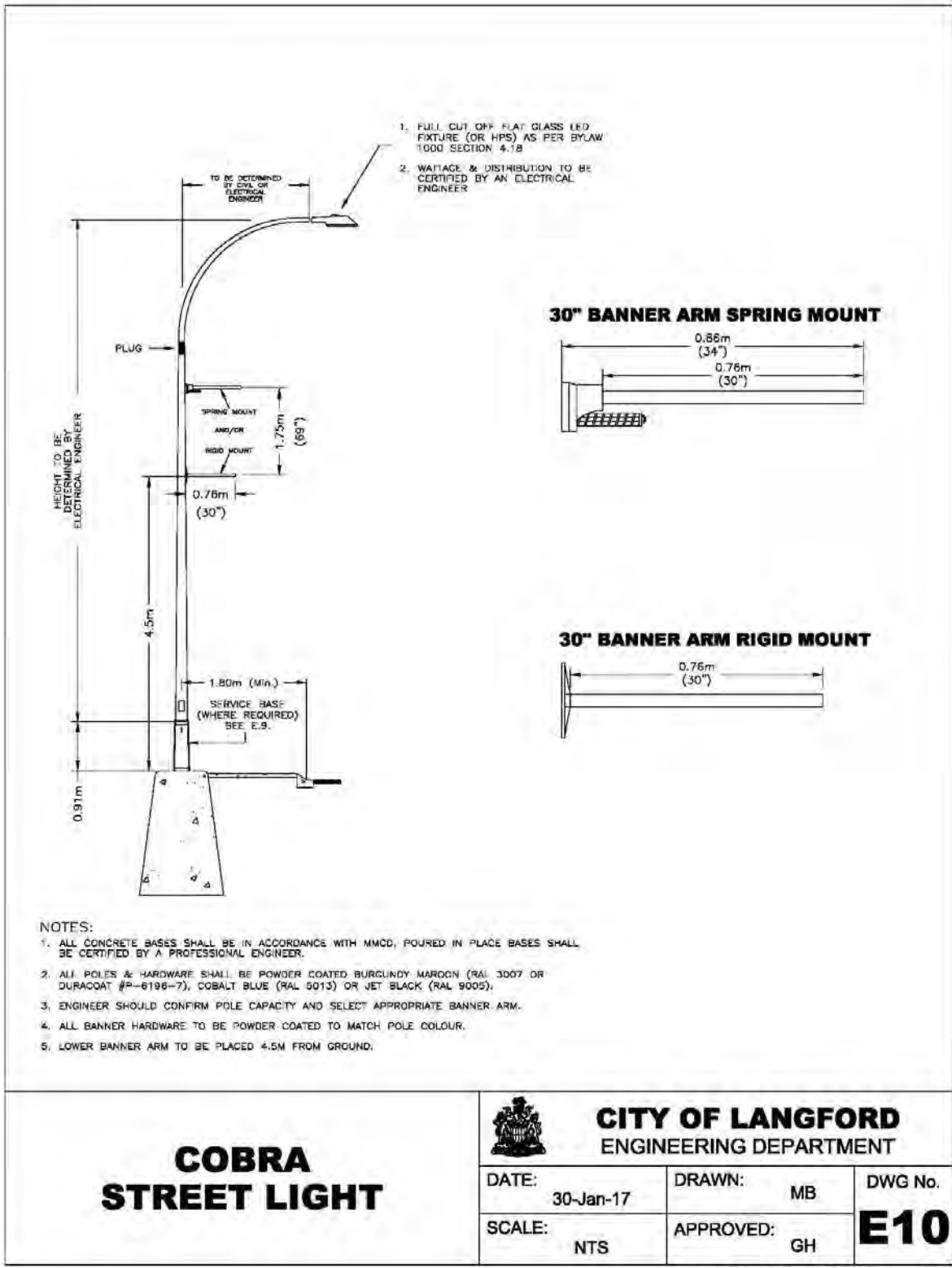

Last Revised: Bylaw 1669, February 2017

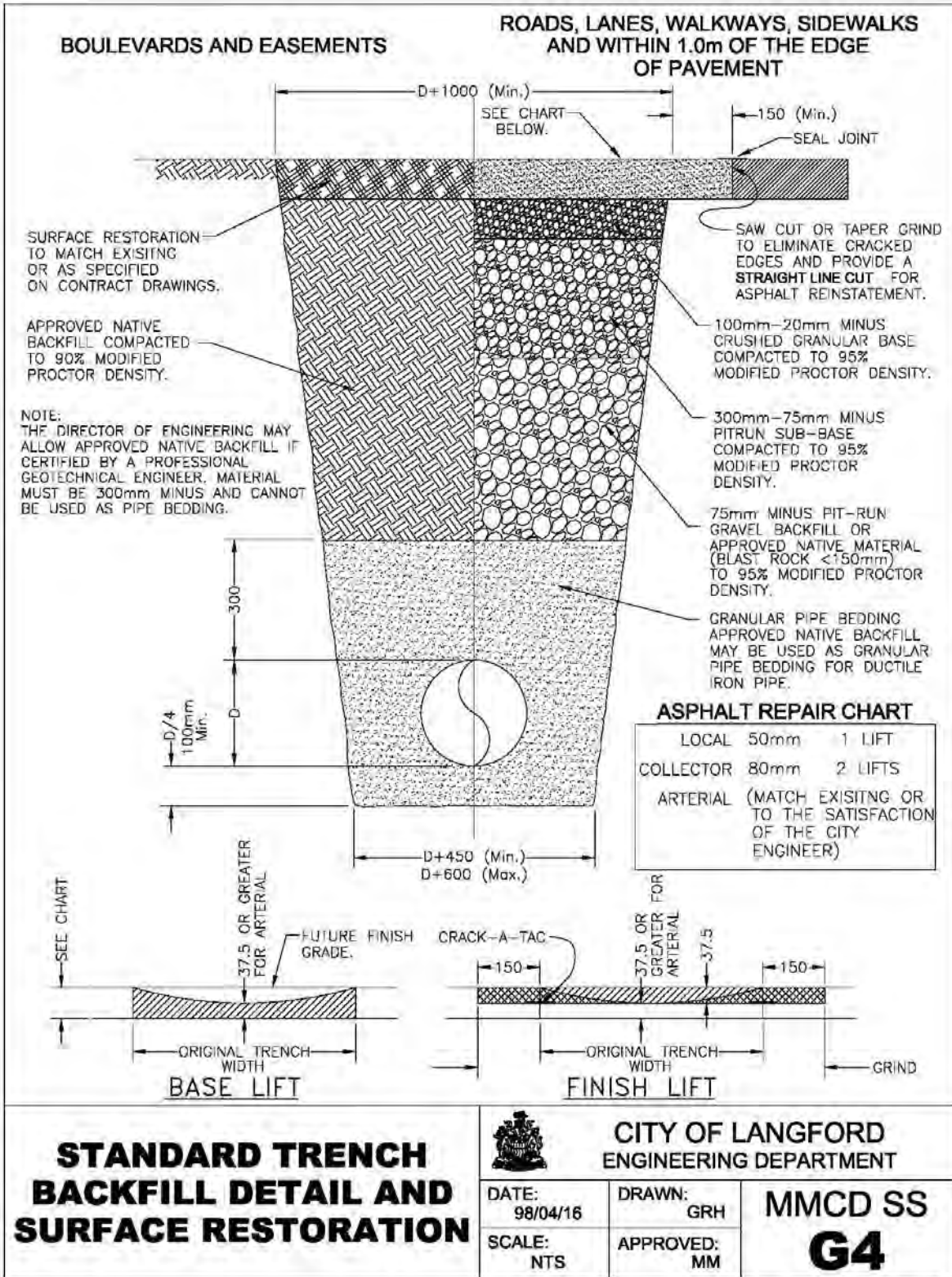

TYPICAL SECTION (COLLECTOR, INDUSTRIAL, ARTERIAL)

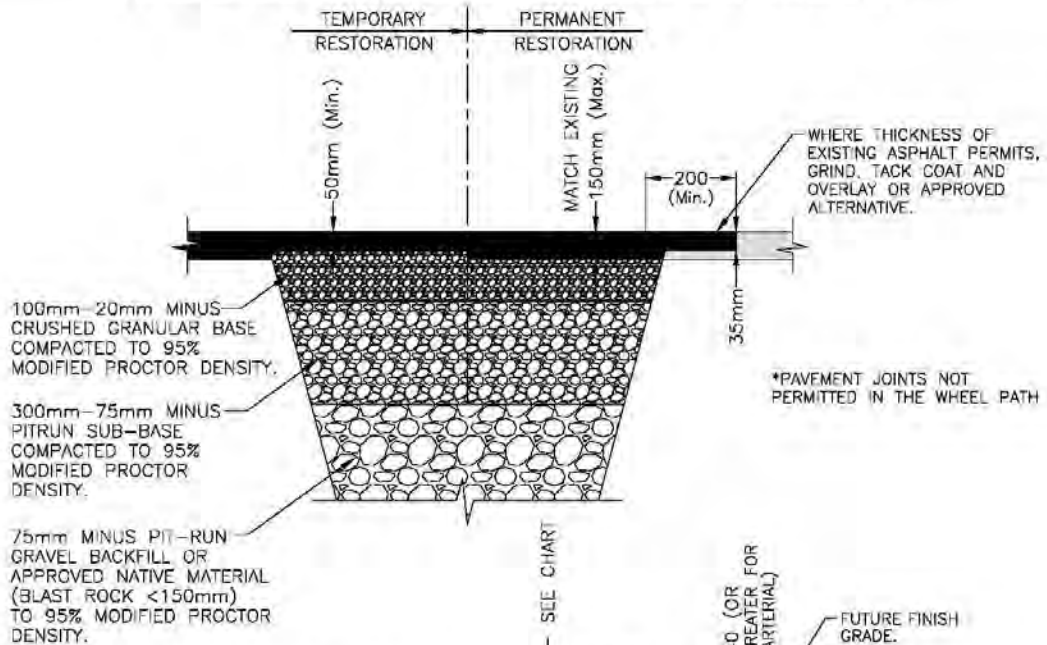

PAVEMENT RESTORATION

ROADS, LANES, WALKWAYS, SIDEWALKS
AND WITHIN 1.0m OF THE EDGE
OF PAVEMENT

NTS

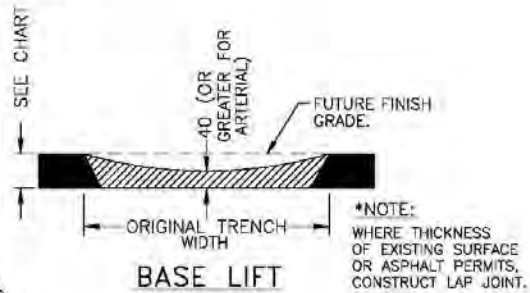
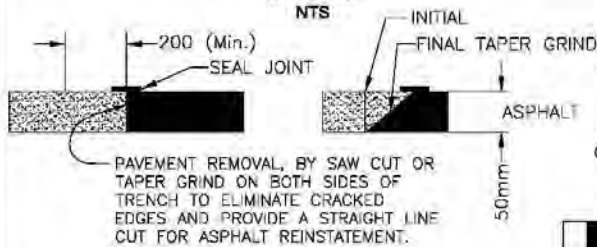

Lap Joint

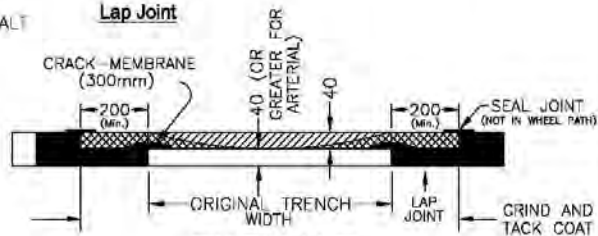

ASPHALT THICKNESS

LOCAL	50mm	1 LIFT
COLLECTOR	80mm	2 LIFTS
ARTERIAL (MATCH EXISTING OR AS PER THE CITY ENGINEER)		
*SPECIFIED ASPHALT THICKNESSES DO NOT INCLUDE SURFACE TREATMENTS.		

*FOR LOCAL ROADS ONLY

	BASE	SUB BASE
LOCAL	100mm	250mm

PAVEMENT STRUCTURE & RESTORATION



CITY OF LANGFORD
ENGINEERING DEPARTMENT

DATE:
11/03/02

DRAWN:
TB

MMCD SS

SCALE:
NTS

APPROVED:
MM

G5

Last Revised: Bylaw 1817, February 2019

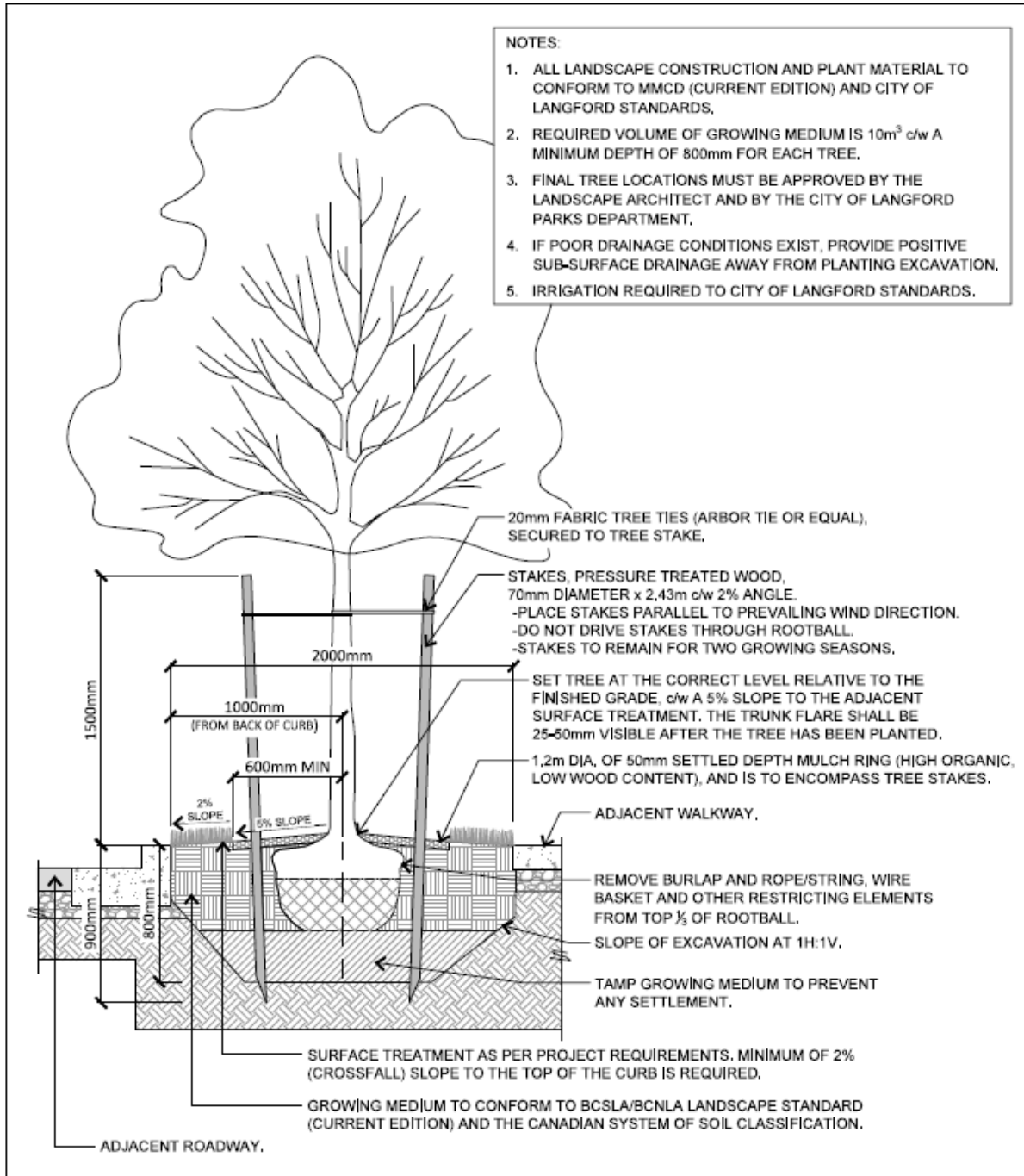

TREE PLANTING DETAIL
 Boulevard Tree Offset from Roadway Curb



CITY OF LANGFORD
 PARKS DEPARTMENT

DATE: 28-Feb-23	DRAWN: TMM	MMCD SS L1(a)
SCALE: NTS	APPROVED: YN	

Last Revised: Bylaw 2103, February 2023

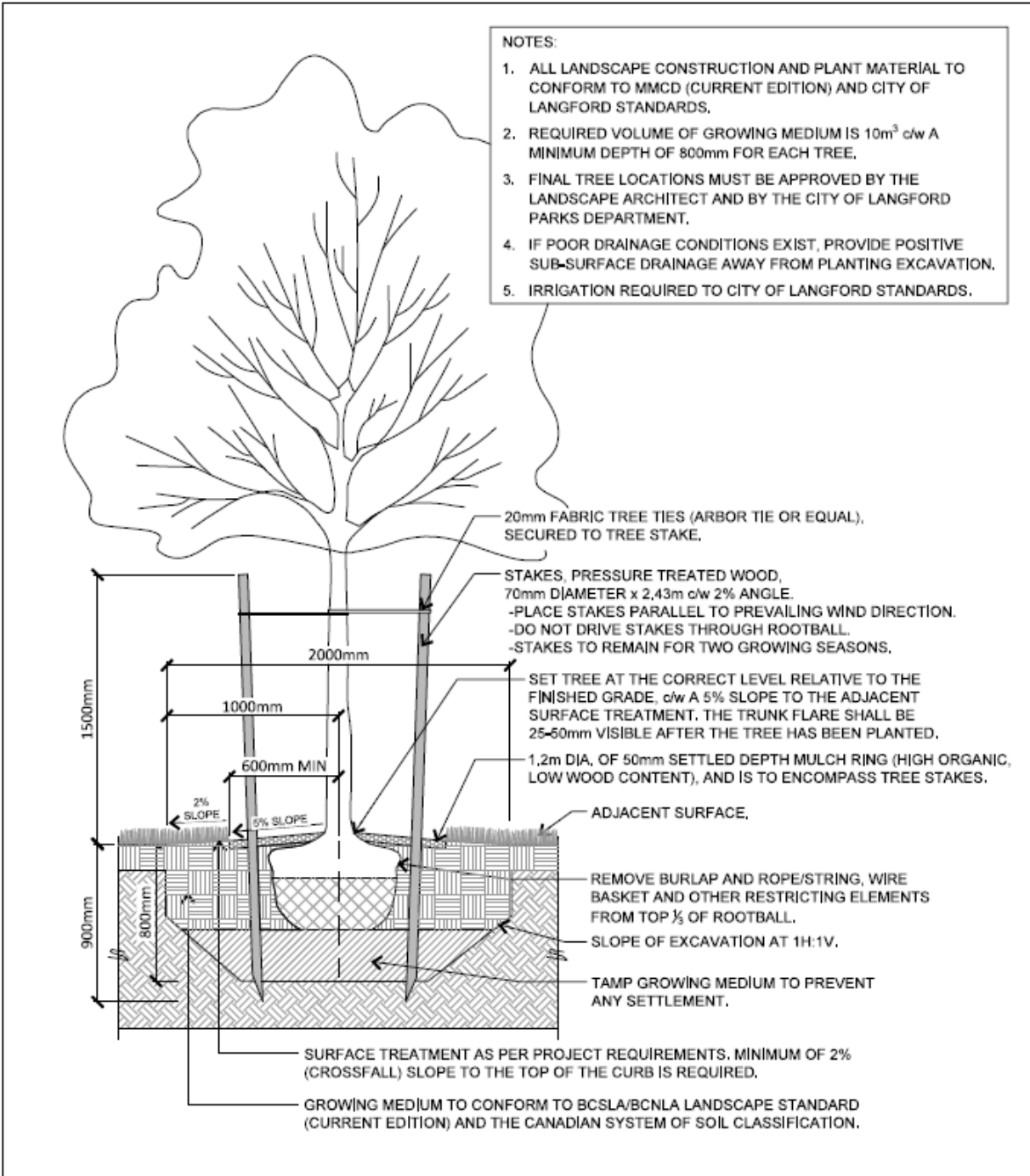

TREE PLANTING DETAIL
 Openspace Trees

 CITY OF LANGFORD PARKS DEPARTMENT		MMCD SS
		L1(b)
DATE: 23-Nov-22	DRAWN: TMM	
SCALE: NTS	APPROVED: YN	

Last Revised: Bylaw 2103, November 2022

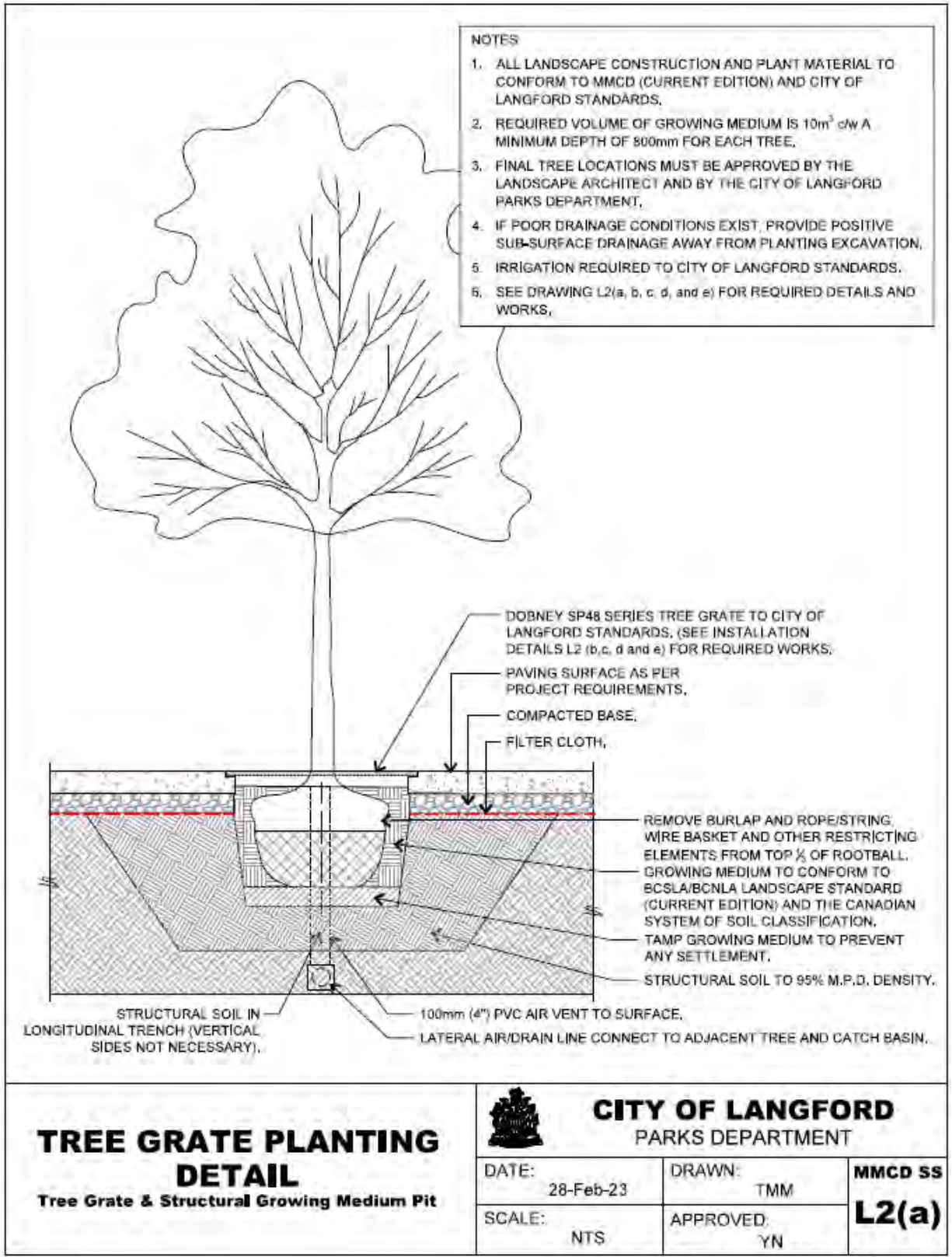

NOTES:

1. ALL LANDSCAPE CONSTRUCTION AND PLANT MATERIAL TO CONFORM TO MMCD (CURRENT EDITION) AND CITY OF LANGFORD STANDARDS.
2. REQUIRED VOLUME OF GROWING MEDIUM IS 10m³ c/w A MINIMUM DEPTH OF 800mm FOR EACH TREE.
3. FINAL TREE LOCATIONS MUST BE APPROVED BY THE LANDSCAPE ARCHITECT AND BY THE CITY OF LANGFORD PARKS DEPARTMENT.
4. IF POOR DRAINAGE CONDITIONS EXIST, PROVIDE POSITIVE SUB-SURFACE DRAINAGE AWAY FROM PLANTING EXCAVATION.
5. IRRIGATION REQUIRED TO CITY OF LANGFORD STANDARDS.

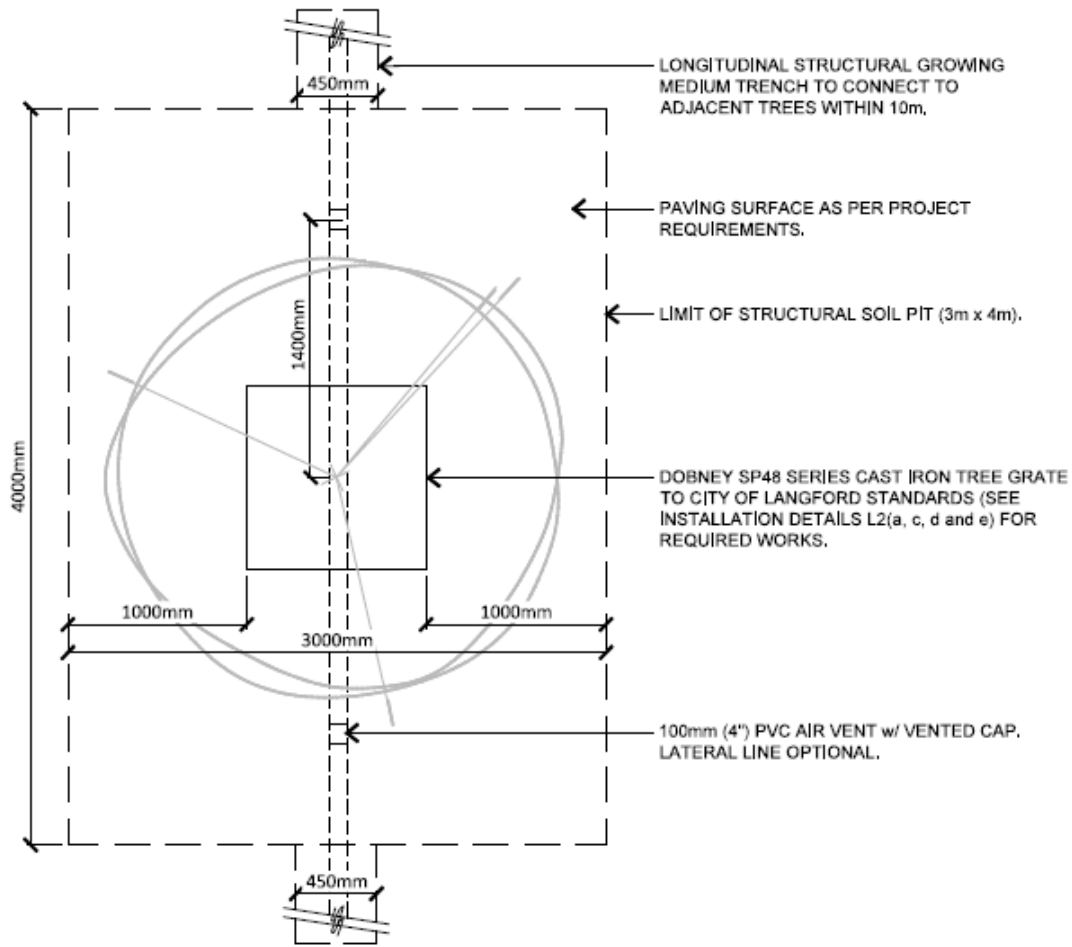

PLAN VIEW

**TREE GRATE PLANTING
DETAIL**
Tree Grate & Structural Growing Medium Pit



CITY OF LANGFORD
PARKS DEPARTMENT

DATE: 28-Feb-23	DRAWN: TMM	MMCD SS L2(b)
SCALE: NTS	APPROVED: YN	

Last Revised: Bylaw 2103, February 2023

NOTES:

1. ALL LANDSCAPE CONSTRUCTION AND PLANT MATERIAL TO CONFORM TO MMCD (CURRENT EDITION) AND CITY OF LANGFORD STANDARDS.
2. REQUIRED VOLUME OF GROWING MEDIUM IS 10m³ c/w A MINIMUM DEPTH OF 800mm FOR EACH TREE.
3. FINAL TREE LOCATIONS MUST BE APPROVED BY THE LANDSCAPE ARCHITECT AND BY THE CITY OF LANGFORD PARKS DEPARTMENT.
4. IF POOR DRAINAGE CONDITIONS EXIST, PROVIDE POSITIVE SUB-SURFACE DRAINAGE AWAY FROM PLANTING EXCAVATION.
5. IRRIGATION REQUIRED TO CITY OF LANGFORD STANDARDS.

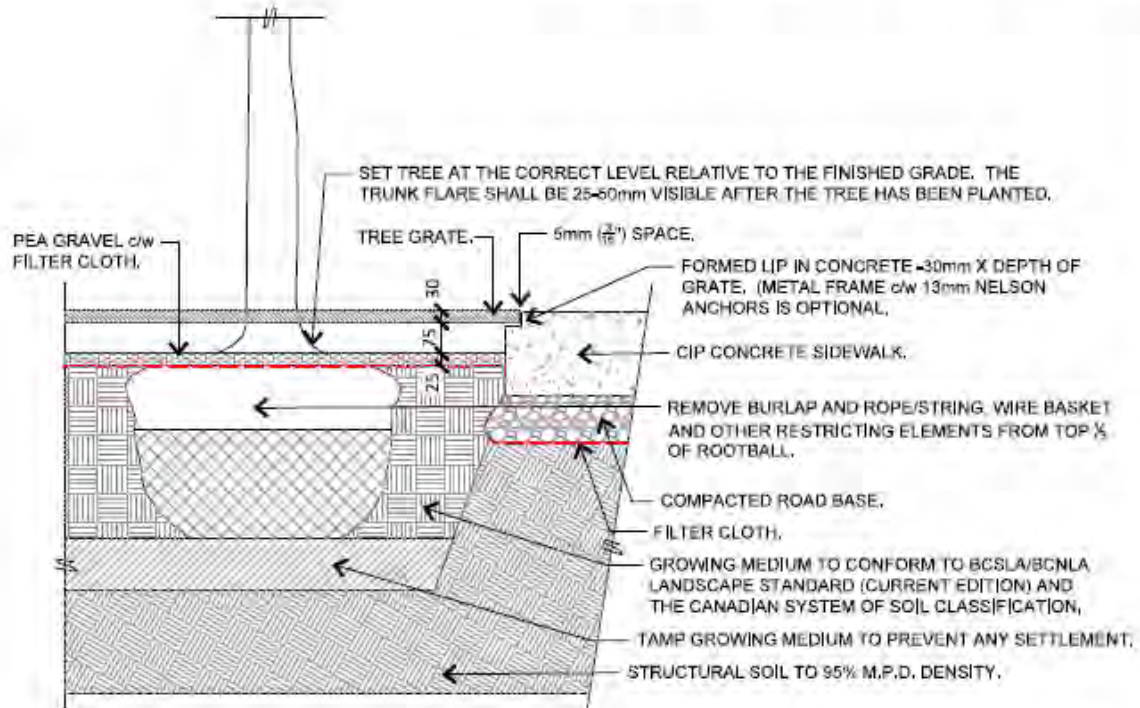

**TREE GRATE
INSTALLATION DETAIL**
Within Sidewalks and Plazas (Concrete)



CITY OF LANGFORD
PARKS DEPARTMENT

DATE: 28-Feb-23	DRAWN: TMM	MMCD SS L2(c)
SCALE: NTS	APPROVED: YN	

Last Revised: Bylaw 2103, February 2023

- NOTES:
1. ALL LANDSCAPE CONSTRUCTION AND PLANT MATERIAL TO CONFORM TO MMCD (CURRENT EDITION) AND CITY OF LANGFORD STANDARDS.
 2. REQUIRED VOLUME OF GROWING MEDIUM IS 10m³ c/w A MINIMUM DEPTH OF 800mm FOR EACH TREE.
 3. FINAL TREE LOCATIONS MUST BE APPROVED BY THE LANDSCAPE ARCHITECT AND BY THE CITY OF LANGFORD PARKS DEPARTMENT.
 4. IF POOR DRAINAGE CONDITIONS EXIST, PROVIDE POSITIVE SUB-SURFACE DRAINAGE AWAY FROM PLANTING EXCAVATION.
 5. IRRIGATION REQUIRED TO CITY OF LANGFORD STANDARDS.

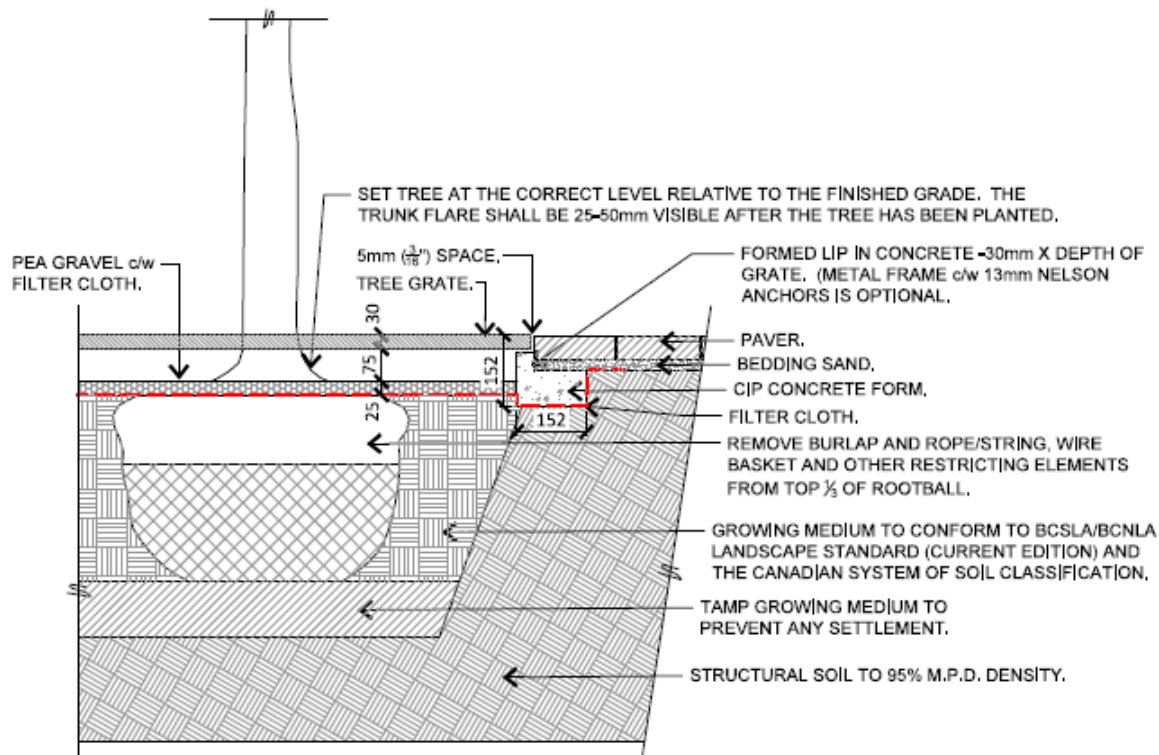

**TREE GRATE
INSTALLATION DETAIL**
Within Sidewalks and Plazas (Pavers)



CITY OF LANGFORD
PARKS DEPARTMENT

DATE: 28-Feb-23	DRAWN: TMM	MMCD SS L2(d)
SCALE: NTS	APPROVED: YN	

Last Revised: Bylaw 2103, February 2023

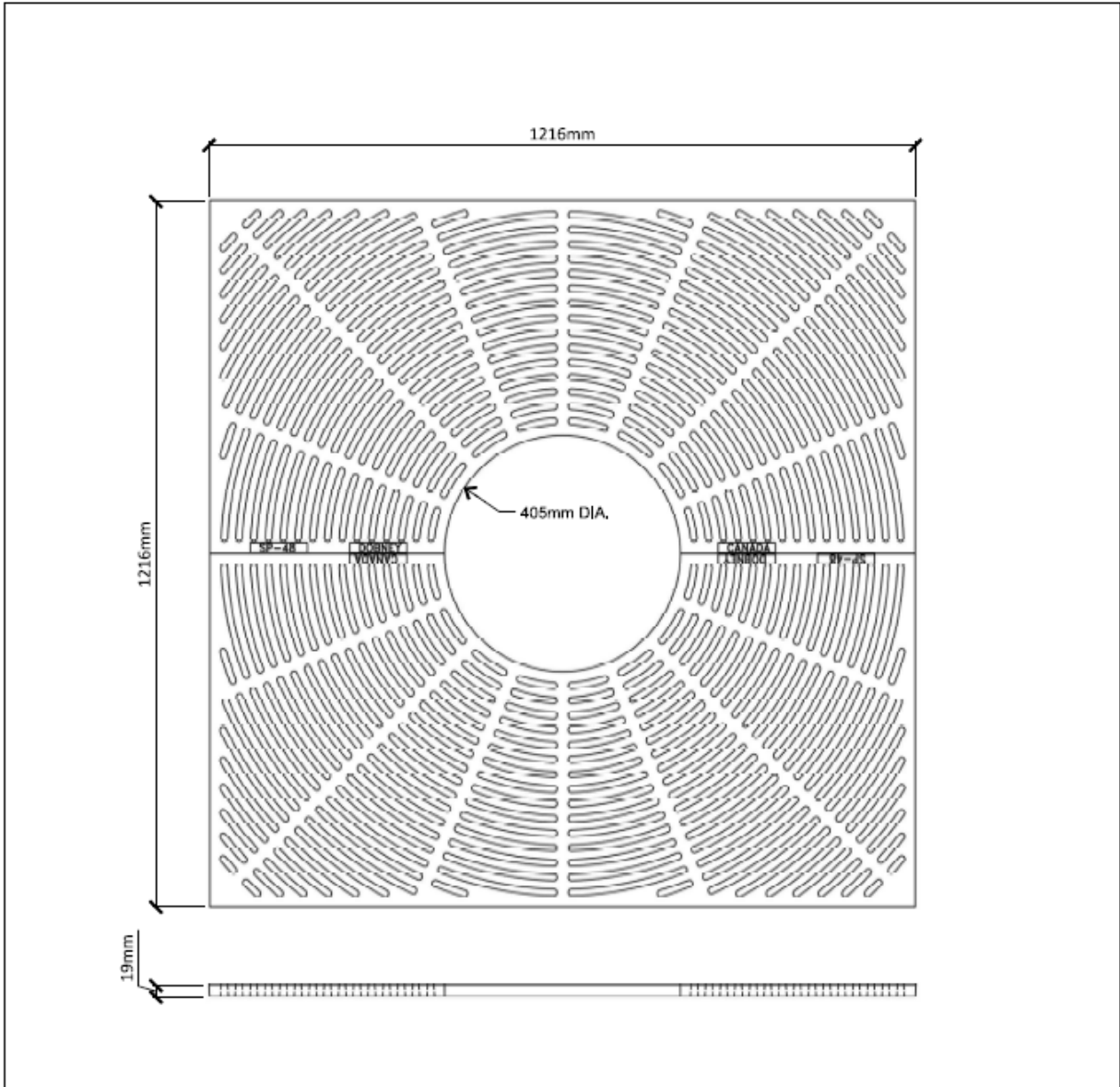

SP-48 TREE GRATE
 DOBNEY FOUNDRY LTD.
 SURREY, BC

TREE GRATE DETAIL Specification (Dobney Foundry Ltd.)	 CITY OF LANGFORD PARKS DEPARTMENT		MMCD SS L2(e)
	DATE: 28-Feb-23	DRAWN: TMM	
	SCALE: NTS	APPROVED: YN	

Last Revised: Bylaw 2103, February 2023

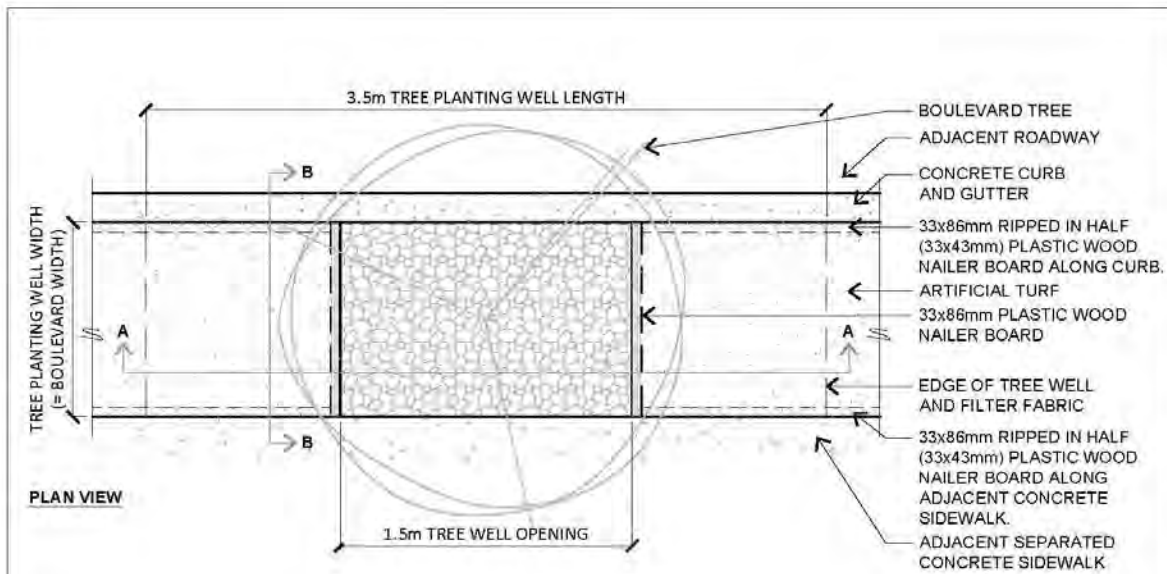

REFER TO DRAWING L1 FOR TREE INSTALLATION DETAILS c/w 700mm DEPTH OF TOPSOIL AND 50mm BARK MULCH.

TREE RING DRIP IRRIGATION AS PER CITY OF LANGFORD BYLAW 1000.

33x86mm PLASTIC WOOD NAILER BOARD ALONG ALL TREE WELL EDGES. SECURED WITH 300mm LENGTH REBAR STAKES LOCATED ON ARTIFICIAL TURF SIDE @ 600mm O.C. ARTIFICIAL TURF TO WRAP OVER EDGE OF WOOD NAILER BOARD (43mm) AND TO BE SECURED TO TREE WELL SIDE OF NAILER BOARD.

33x86mm PLASTIC WOOD NAILER BOARD ALONG ALL TREE WELL EDGES, SECURED WITH 300mm LENGTH REBAR STAKES LOCATED ON ARTIFICIAL TURF SIDE @ 600mm O.C. ARTIFICIAL TURF TO WRAP OVER EDGE OF WOOD NAILER BOARD (43mm) AND TO BE SECURED TO TREE WELL SIDE OF NAILER BOARD.

SYNTHETIC TURF SURFACE (CONTACT PARKS FOR ARTIFICIAL TURF SPECIFICATIONS) TO BE LOCATED 16mm FROM TOP OF TREE PLANTING AREA c/w 100mm DEPTH OF 19mm MINUS GRANULAR BASE.

700mm DEPTH OF TAMPED/SETTLED GROWING MEDIUM.

NON-WOVEN GEOTEXTILE BASE LAYER (NILEX 4545 OR APPROVED EQUAL).

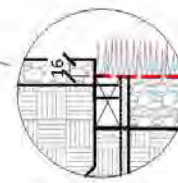
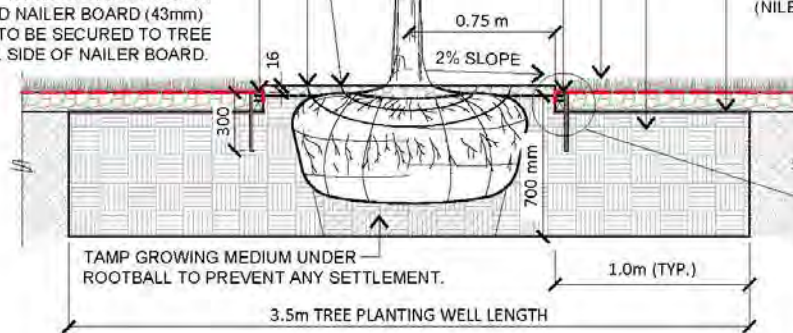

ENLARGEMENT SCALE N.T.S.

CROSS SECTION "A"

ARTIFICIAL TURF INSTALLATION AT BOULEVARD TREE



CITY OF LANGFORD
PARKS DEPARTMENT

DATE:	08-Jan-18	DRAWN:	tmm	MMCD SS L2(fa)
SCALE:	NTS	APPROVED:	CM	

Last Revised: Bylaw 1817, February 2019

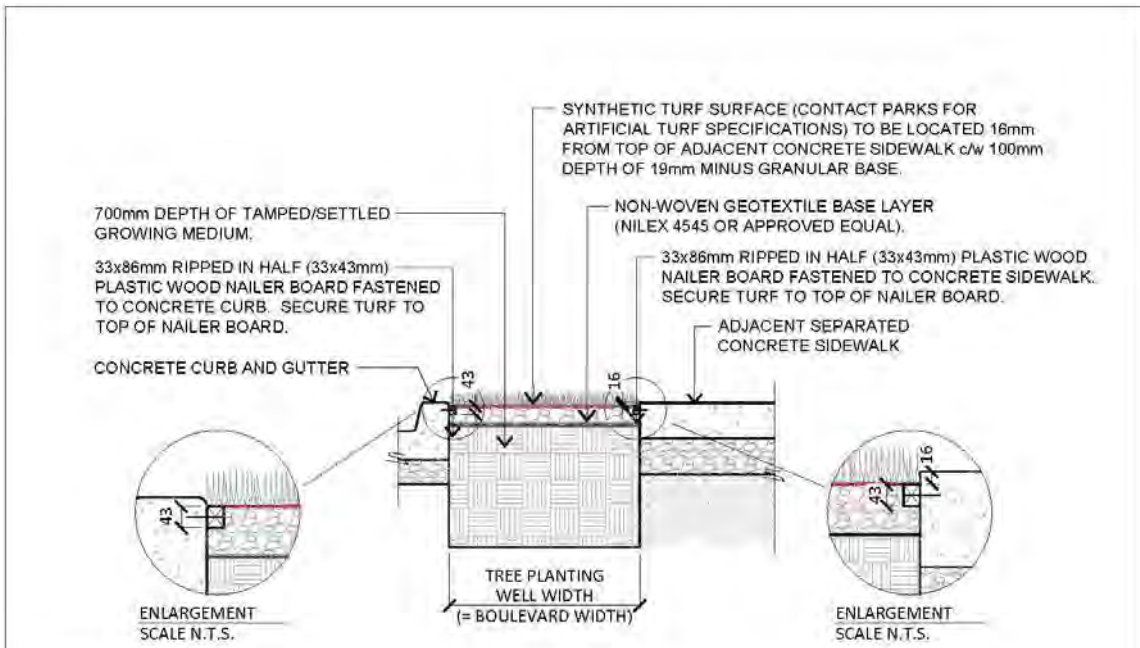

CROSS SECTION "B"

ARTIFICIAL TURF GRASS INSTALLATION PROCEDURE FOR STREET TREES

- EXCAVATE MATERIAL FOR TREE PIT TO DEPTH OF 700mm, LENGTH OF 3.5m AND THE WIDTH OF THE BOULEVARD (VARIES). THIS IS REFERRED TO AS THE TREE PLANTING WELL.
- INSTALL AND TAMP GROWING MEDIUM IN 200mm LIFTS TO A DEPTH OF 700mm SETTLED DEPTH. (THIS MAY HAVE TO BE ADJUSTED BASED ON DEPTH OF UNDERGROUND UTILITIES WITHIN THE BOULEVARD) WITHIN THE TREE PLANTING AREA.
- INSTALL 33x86mm RIPPED IN HALF (33x43mm) PLASTIC WOOD NAILER BOARD ALONG SIDEWALK AND CURB AND SECURE TURF TO TOP OF NAILER BOARD.
- INSTALL 33x86mm PLASTIC WOOD NAILER BOARD ALONG THE OUTSIDE OF THE TREE WELL AND SECURE TURF TO TREE WELL SIDE OF NAILER BOARD.
- PLANT TREE IN CENTRE OF 1.5m TREE WELL OPENING PRIOR TO ARTIFICIAL TURF INSTALLATION, TO PREVENT SETTLEMENT OF ARTIFICIAL TURF BASE.
- INSTALL LAYER OF NON-WOVEN GEOTEXTILE FABRIC OVER TAMPED GROWING MEDIUM WITHIN ARTIFICIAL TURF AREA AT A WIDTH OF 1m ON EITHER SIDE OF THE TREE WELL.
- INSTALL 100mm OF 19mm MINUS CRUSH (ROAD BASE) OVER THE FABRIC AND COMPACT BY TAMPING. INSTALL GROWING MEDIUM WITHIN THE TREE WELL TO BRING LEVEL TO 50mm BELOW FINAL GRADE.
- APPLY WATER TO THE GROWING MEDIUM AND ROAD BASE TO REDUCE SETTLEMENT AND BRING GROWING MEDIUM WITHIN THE TREE WELL UP TO FINAL GRADE. ADD REQUIRED ROAD BASE OUTSIDE THE TREE PIT TO BRING TO FINAL GRADE AND TAMP. THE INTENT IS TO PREVENT SETTLEMENT OF THE GROWING MEDIUM AND ARTIFICIAL TURF BASE WITHIN THE TREE WELL AREA.
- INSTALL ARTIFICIAL TURF AS PER MANUFACTURER'S SPECIFICATIONS.

**ARTIFICIAL TURF
INSTALLATION AT
BOULEVARD TREE**



**CITY OF LANGFORD
PARKS DEPARTMENT**

DATE: 08-Jan-18	DRAWN: tmm	MMCD SS L2(f_b)
SCALE: NTS	APPROVED: CM	

Last Revised: Bylaw 1817, February 2019

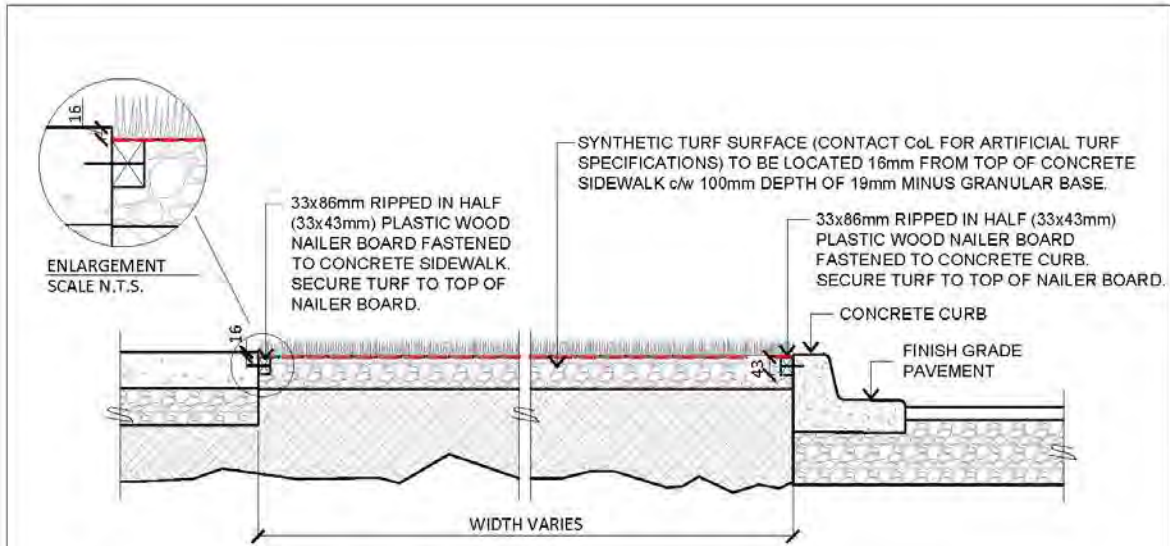

ARTIFICIAL TURF INSTALLATION BETWEEN CONCRETE SIDEWALK AND CONCRETE CURB

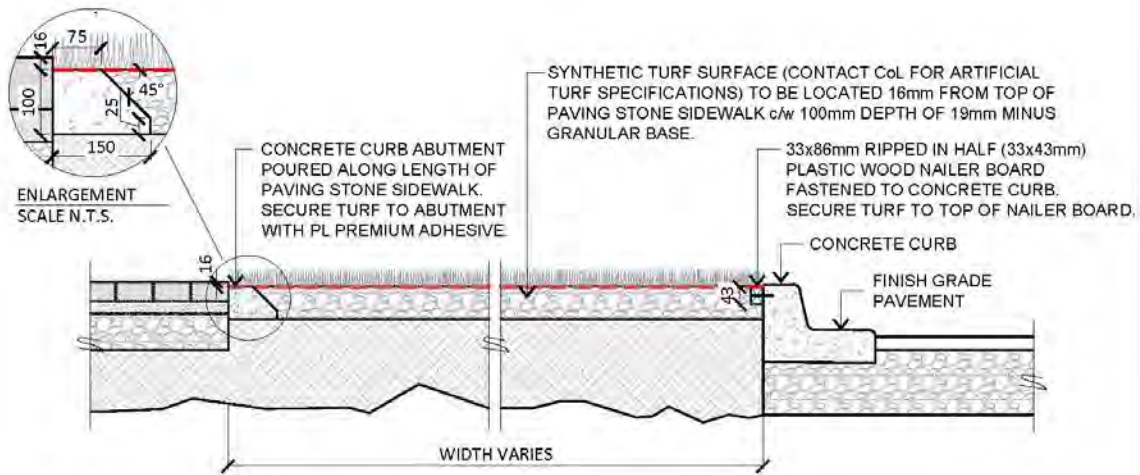

ARTIFICIAL TURF INSTALLATION BETWEEN PAVING STONE SIDEWALK AND CONCRETE CURB

**ARTIFICIAL TURF
INSTALLATION
ALONG BOULEVARD**



**CITY OF LANGFORD
PARKS DEPARTMENT**

DATE: 11-Sep-17	DRAWN: tmm	MMCD SS L2(g)
SCALE: NTS	APPROVED: CM	

Last Revised: Bylaw 1817, February 2019

NOTES:

- ALL METHODS AND MATERIALS TO CONFORM TO THE CITY OF LANGFORD BYLAWS 1000 & 1669 (CURRENT EDITIONS).
- PROTECT PLANT MATERIAL FROM DAMAGE DURING TRANSPORTATION AND PLANTING.
- LOCATE AND FLAG ALL BURIED UTILITIES IN "BC-1 CALL" PLANTING BEDS PRIOR TO DIGGING AND ENSURE THAT UTILITIES ARE PROTECTED DURING CONSTRUCTION.
- PLANT MATERIAL DENSITY / SPACING TBD BY PARKS MANAGER.
- PLACE ROOT BALL AT SAME FINISH ELEVATION AS ORIGINAL NURSERY PLANTING.
- THIS DETAIL REFLECTS MIN 3.5m WIDTH BOULEVARDS.

SYNTHETIC TURF SURFACE (CONTACT CoL FOR ARTIFICIAL TURF SPECIFICATIONS) TO BE LOCATED 16mm FROM TOP OF CURB c/w 100mm DEPTH OF 19mm MINUS GRANULAR BASE

33x86mm RIPPED IN HALF (33x43mm) PLASTIC WOOD NAILER BOARD FASTENED TO CONCRETE CURB. SECURE TURF TO TOP OF NAILER BOARD.

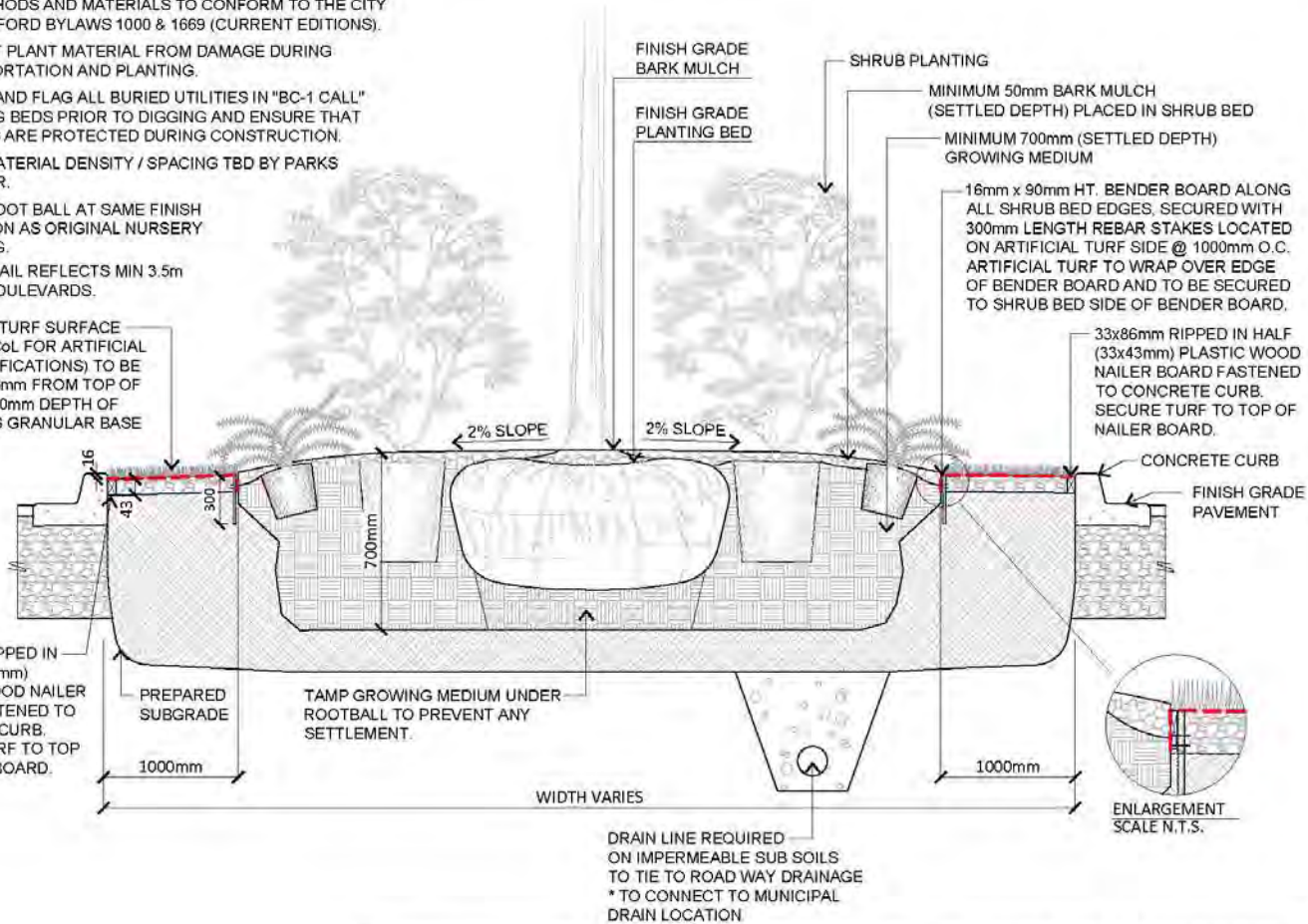

**ARTIFICIAL TURF
INSTALLATION FOR
MIN 3.5m CENTER MEDIAN**



CITY OF LANGFORD
PARKS DEPARTMENT

DATE: 11-Sep-17	DRAWN: TMM	MMCD SS L2(h)
SCALE: NTS	APPROVED: MM	

Last Revised: Bylaw 1817, February 2019

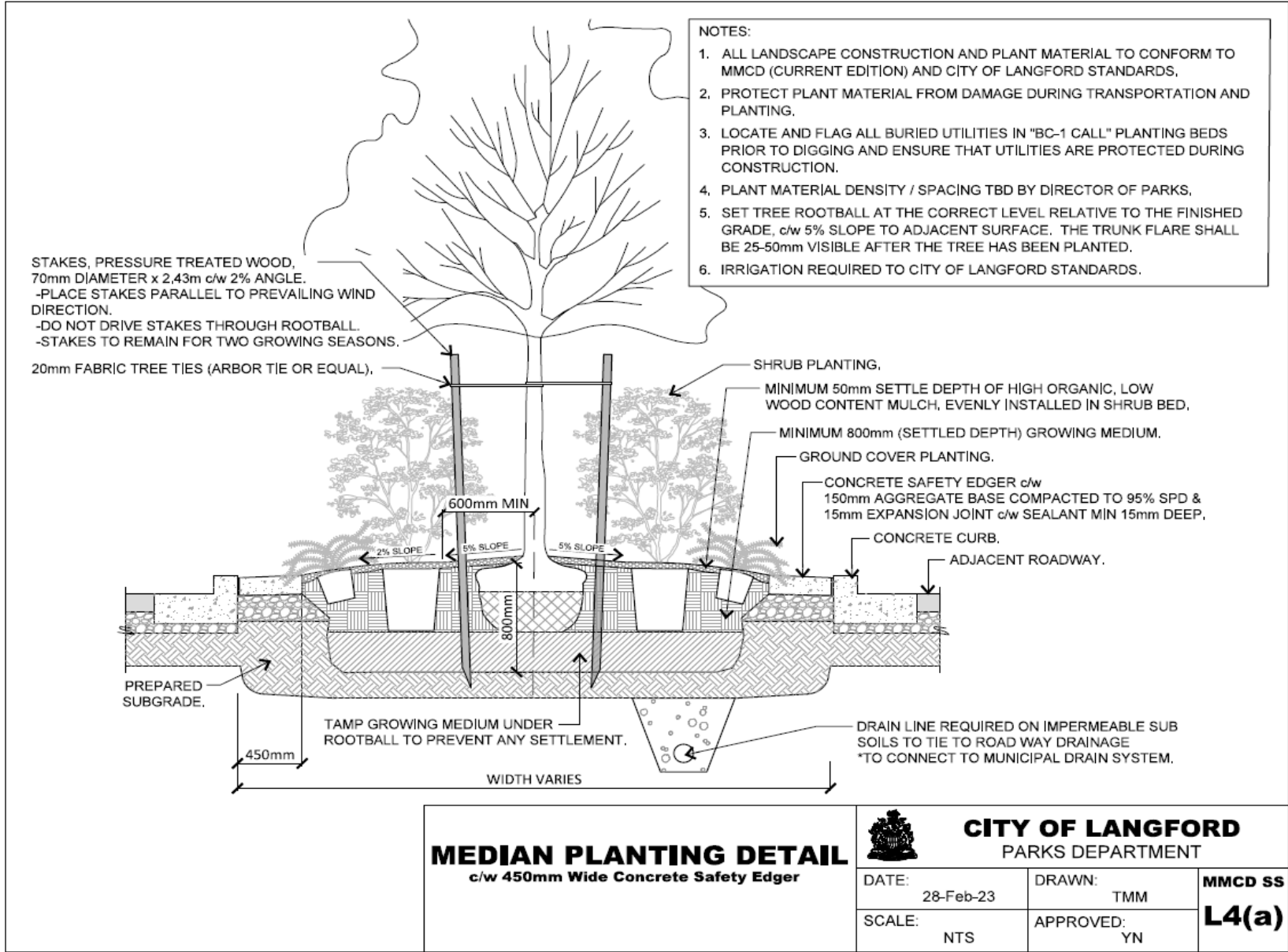

MEDIAN PLANTING DETAIL
 c/w 450mm Wide Concrete Safety Edger



CITY OF LANGFORD
 PARKS DEPARTMENT

DATE: 28-Feb-23	DRAWN: TMM	MMCD SS L4(a)
SCALE: NTS	APPROVED: YN	

Last Revised: Bylaw 2103, February 2023

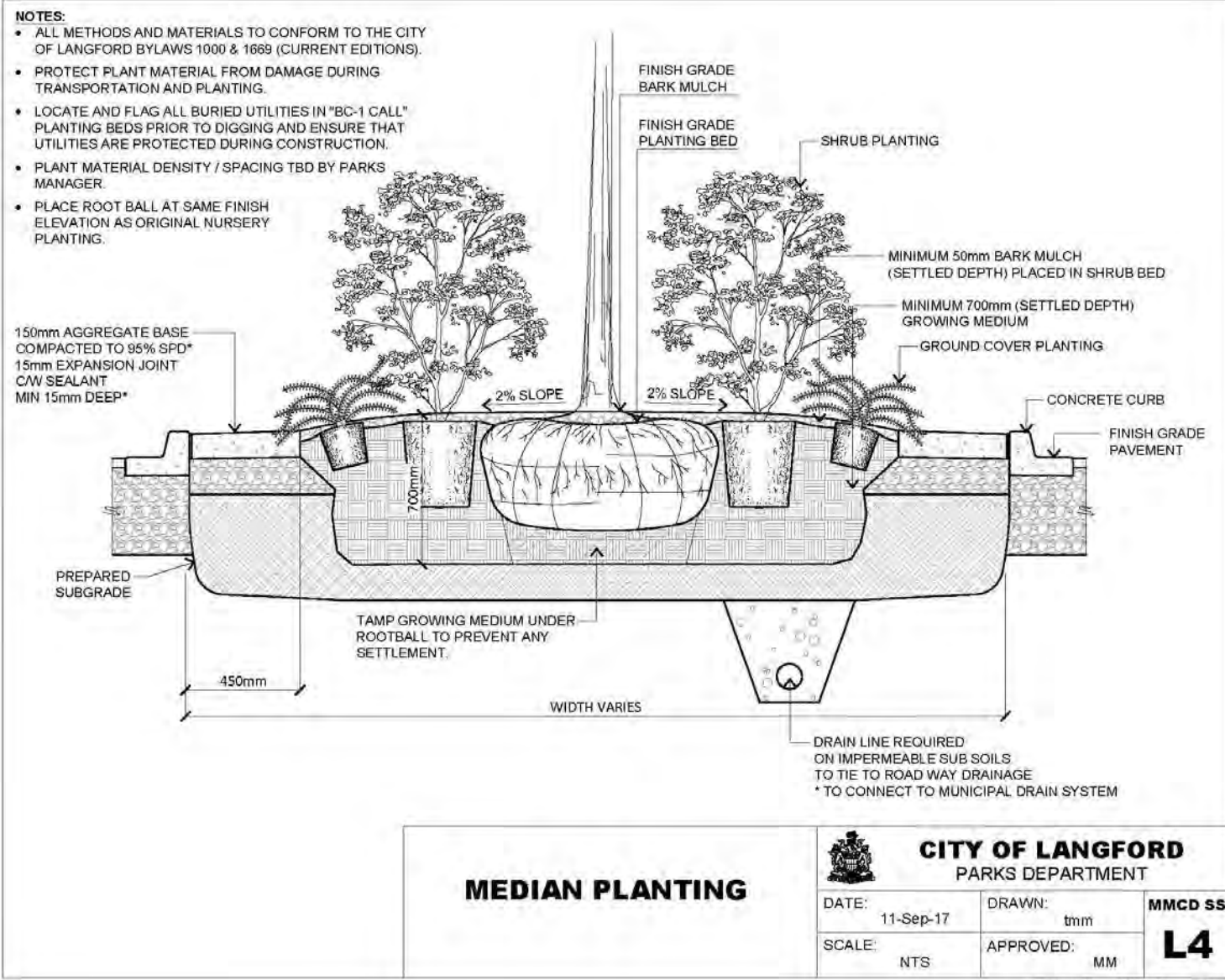

MEDIAN PLANTING

CITY OF LANGFORD
PARKS DEPARTMENT

DATE: 11-Sep-17	DRAWN: tmm	MMCD SS L4
SCALE: NTS	APPROVED: MM	

Last Revised: Bylaw 1817, February 2019

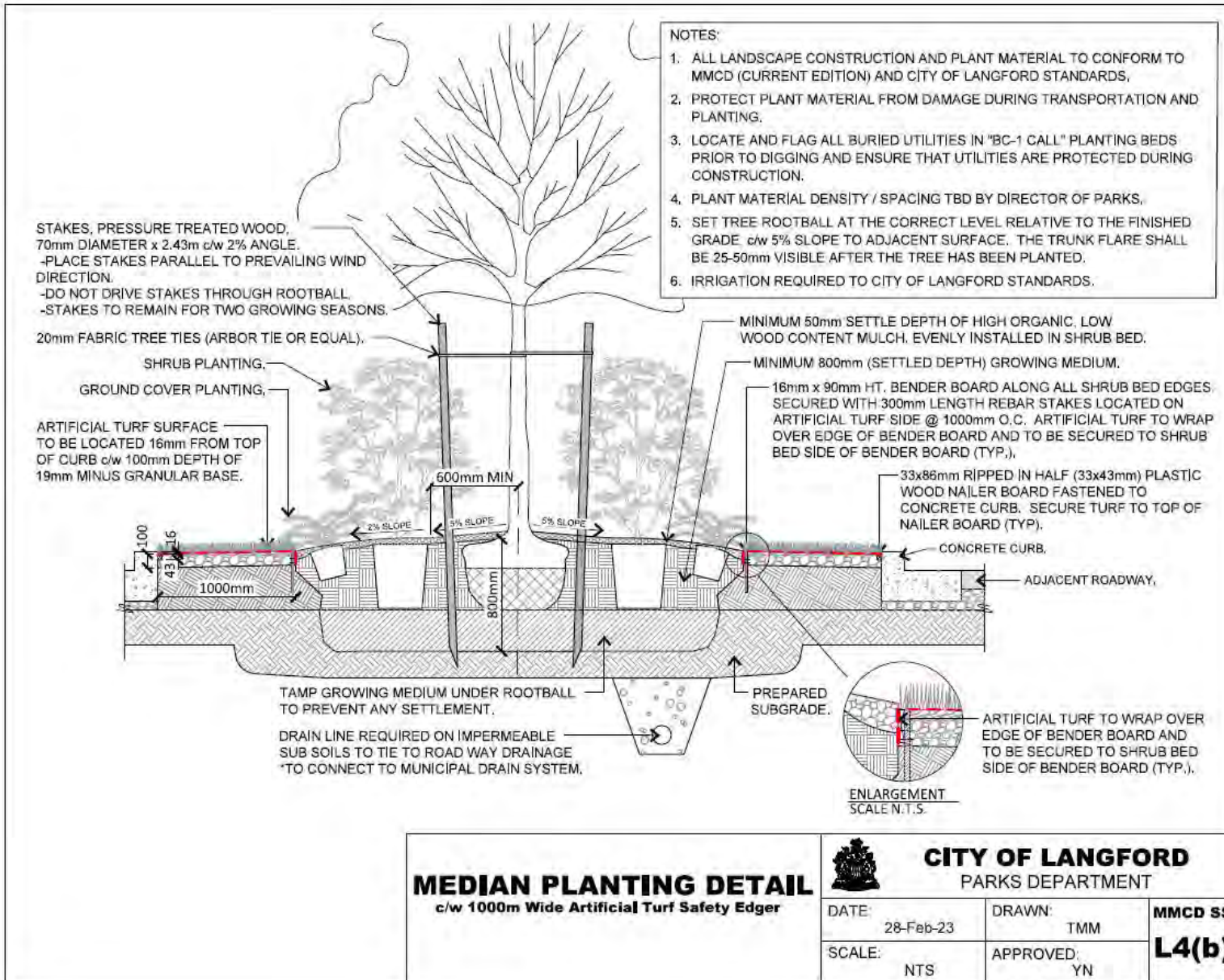

MEDIAN PLANTING DETAIL
 c/w 1000m Wide Artificial Turf Safety Edger

 CITY OF LANGFORD PARKS DEPARTMENT		MMCD SS L4(b)
SCALE: NTS	APPROVED: YN	

Last Revised: Bylaw 2103, February 2023

NOTES:

1. ALL LANDSCAPE CONSTRUCTION AND MATERIALS TO CONFORM TO MMCD (CURRENT EDITION) AND CITY OF LANGFORD STANDARDS.
2. ALL LAWN AREAS TO BE GRADED TO A MINIMUM OF 2% EVEN SLOPE TO NEAREST DRAIN OR SWALE.
3. 150mm DEPTH OF GROWING MEDIUM UNDER ALL SODDED AREAS SHALL BE SPREAD EVENLY OVER THE APPROVED SUBGRADE.
4. SOD SHALL BE LAID IN SMOOTH EVEN STAGGERED ROWS, AND CLOSELY KNIT TOGETHER IN SUCH A MANNER THAT NO OPEN JOINTS WIDER THAN 3mm ARE VISIBLE, JOINTS ARE STAGGERED A MINIMUM 25mm, AND NO PIECES ARE STRETCHED OR OVERLAPPED.
5. SOD SHALL BE LAID SMOOTH AND FLUSH WITH ADJOINING / EXISTING GRASS AREAS, PAVING AND TOP SURFACE OF CURBS.
6. THE SOD AREA SHALL BE ROLLED, TAMPED, OR PLANKED WITH PLYWOOD PROVIDING SUFFICIENT PRESSURE, TO ENSURE A GOOD BOND BETWEEN SOD AND GROWING MEDIUM.
7. SPACING OF STAKES OR STAPLES SHALL BE ADEQUATE TO ENSURE COMPLETE ANCHORAGE OF THE SOD TO THE GROUND OR AS SPECIFIED BY THE MANUFACTURER.
8. BEFORE PEDESTRIAN TRAFFIC IS PERMITTED ON THE TURF, AND AFTER THE TURF IS WELL ROOTED INTO THE GROWING MEDIUM, PEGS OR STAKES SHALL BE REMOVED OR DRIVEN AT LEAS 50mm BELOW THE SOD SURFACE.
9. IRRIGATION REQUIRED TO CITY OF LANGFORD STANDARDS.

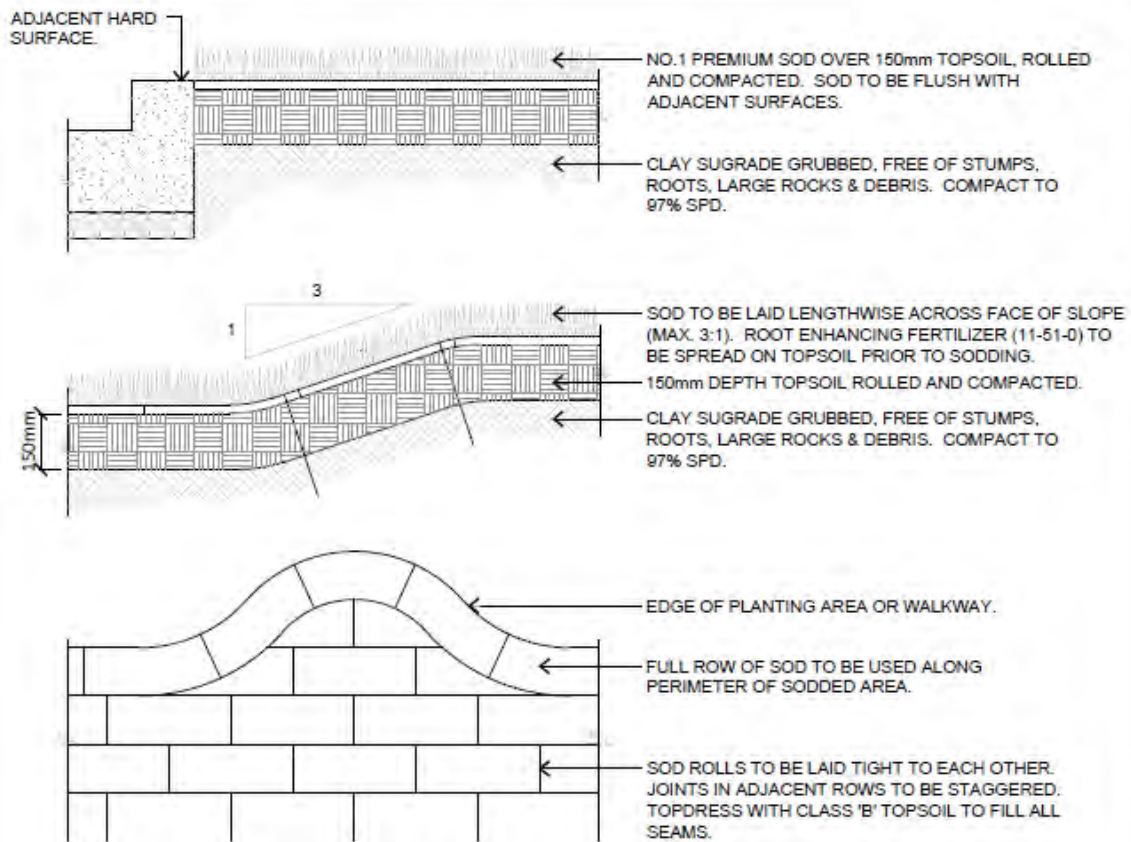

**SOD INSTALLATION
DETAIL**



**CITY OF LANGFORD
PARKS DEPARTMENT**

DATE: 28-Feb-23	DRAWN: TMM	DWG No.
SCALE: NTS	APPROVED: YN	L6(a)

Last Revised: 05/10/2013 February 2017

NOTES:

1. ALL LANDSCAPE CONSTRUCTION AND PLANT MATERIAL TO CONFORM TO MMCD (CURRENT EDITION) AND CITY OF LANGFORD STANDARDS.
2. ALL LAWN AREAS TO BE GRADED TO A MINIMUM OF 2% EVEN SLOPE TO NEAREST DRAIN OR SWALE.
3. PREPARE SEED BED BY ROLLING TO A SMOOTH EVEN SURFACE BROADCAST APPROVED GRASS SEED. MIX MECHANICALLY FROM TWO DIRECTION AT A RATE OF 2.5kg PER 100m² SURFACE AREA.
4. BROADCAST APPROVED NITROGEN FERTILIZER MECHANICALLY FROM TWO DIRECTIONS TO MANUFACTURERS SPECIFICATIONS.
5. ROLL SEED AND FERTILIZER WITH A 100kg ROLLER, RAKE LIGHTLY FROM TWO DIRECTIONS AND ROLL AGAIN.
6. SPRINKLE LIGHTLY WITH WATER UNTIL SATURATED.
7. IRRIGATION REQUIRED TO CITY OF LANGFORD STANDARDS.

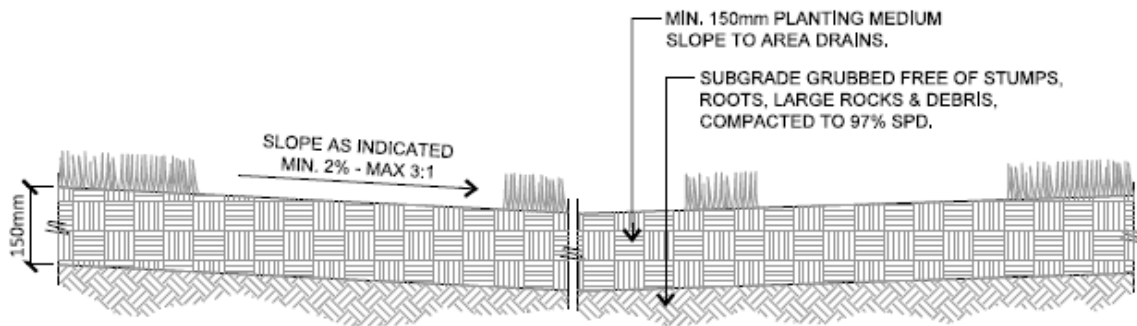

**SEED INSTALLATION
DETAIL**



CITY OF LANGFORD
PARKS DEPARTMENT

DATE: 28-Feb-23	DRAWN: TMM	DWG No. L6(b)
SCALE: NTS	APPROVED: YN	

Last Revised: Bylaw 2103, February 2023

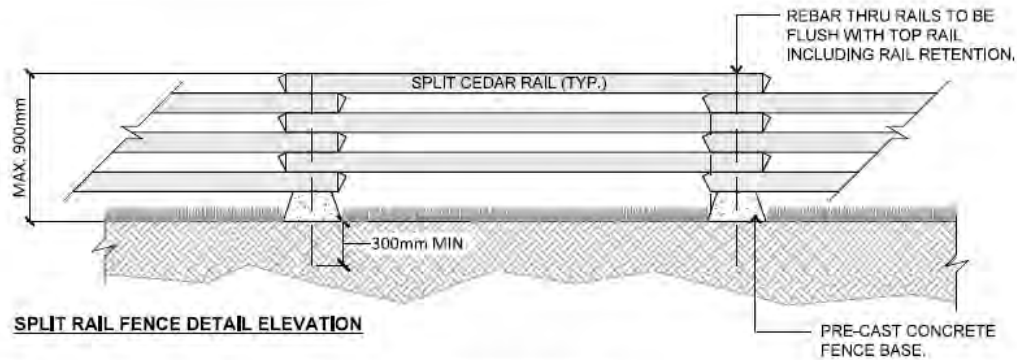

SPLIT RAIL FENCE DETAIL ELEVATION

NOTES:

- ALL METHODS AND MATERIALS TO CONFORM TO THE CITY OF LANGFORD BYLAWS 1000 & 2103 (CURRENT EDITIONS).
- MAXIMUM RAIL LENGTH NOT TO EXCEED 3048mm (10'), UNLESS SPECIFIC APPLICATION REQUIRES DIFFERENT (i.e. TREE PROTECTION, CORNERS, ETC.)
- EACH RAIL TO BE MINIMUM 100mm ϕ AND MAXIMUM 150mm ϕ .
- MAXIMUM ANGLE OF RAILS NOT TO EXCEED 130°, UNLESS SPECIFIC APPLICATION REQUIRES DIFFERENT (i.e. TREE PROTECTION, CORNERS, ETC.)
- FENCE PANELS TO CONTAIN THREE (3) RAILS AND BE MAXIMUM 900mm HEIGHT AT TOP RAIL.
- DRILL RAILS 300mm FROM EITHER END. HAMMER REBAR THROUGH RAILS. REBAR TO BE FLUSH WITH TOP RAIL INCLUDING RAIL RETENTION.
- REBAR ANCHORS TO BE DRIVEN 300mm INTO GROUND.

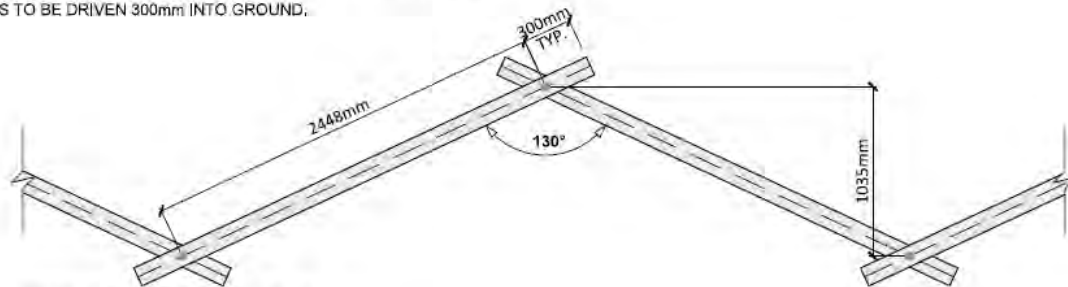

SPLIT RAIL FENCE DETAIL PLAN

**SPLIT RAIL FENCE
DETAIL**



CITY OF LANGFORD
PARKS DEPARTMENT

DATE	28-Feb-23	DRAWN	TMM	MMCD SS L7
SCALE	NTS	APPROVED:	YN	

Last Revised: Bylaw 2103, February 2023

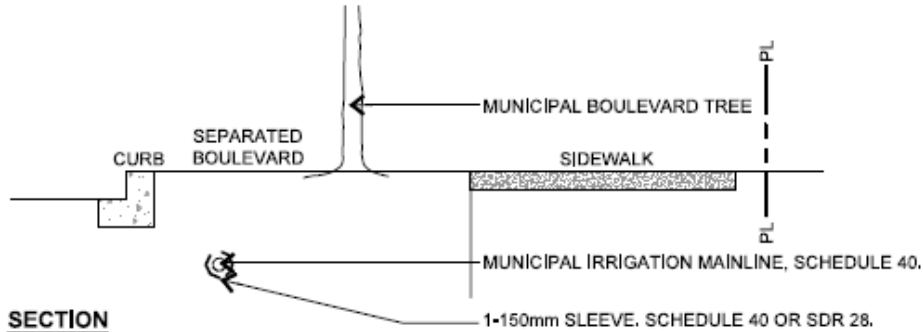
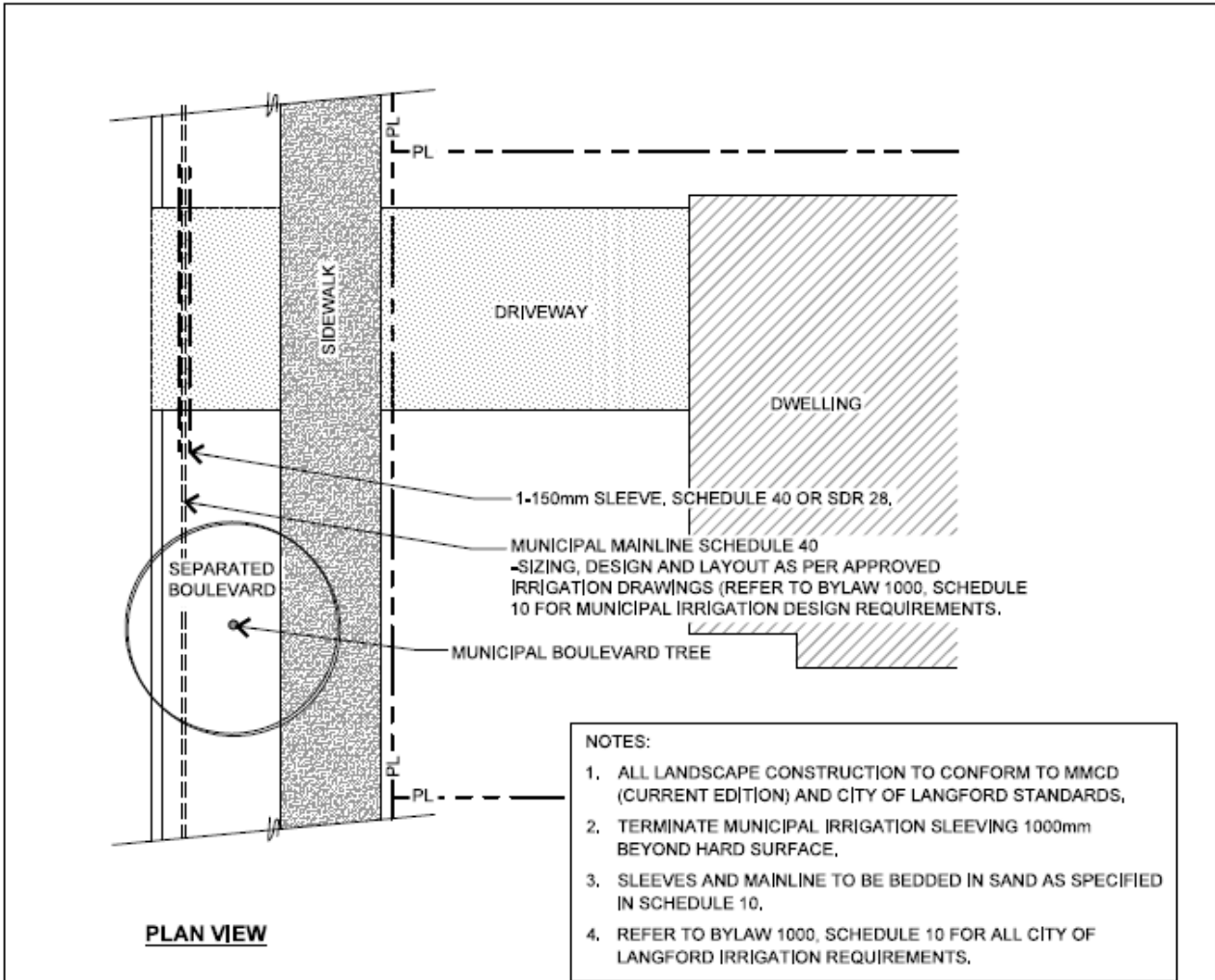

<p>MUNICIPAL IRRIGATION SLEEVING DETAIL Separated Boulevard (Mainline & Sleeving)</p>	 <p>CITY OF LANGFORD PARKS DEPARTMENT</p>		<p>MMCD SS P1</p>
	DATE: 28-Feb-23	DRAWN: TMM	
	SCALE: NTS	APPROVED: YN	

Last Revised: Bylaw 2103, February 2023

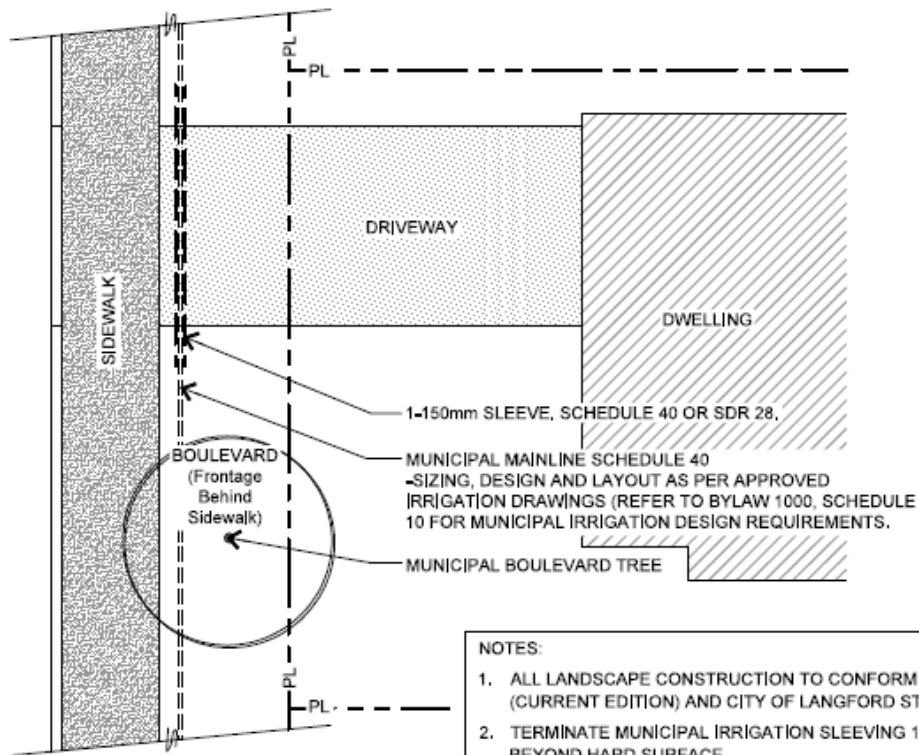

PLAN VIEW

- NOTES:**
1. ALL LANDSCAPE CONSTRUCTION TO CONFORM TO MMCD (CURRENT EDITION) AND CITY OF LANGFORD STANDARDS.
 2. TERMINATE MUNICIPAL IRRIGATION SLEEVING 1000mm BEYOND HARD SURFACE.
 3. SLEEVES AND MAINLINE TO BE BEDDED IN SAND AS SPECIFIED IN SCHEDULE 10.
 4. REFER TO BYLAW 1000, SCHEDULE 10 FOR ALL CITY OF LANGFORD IRRIGATION REQUIREMENTS.

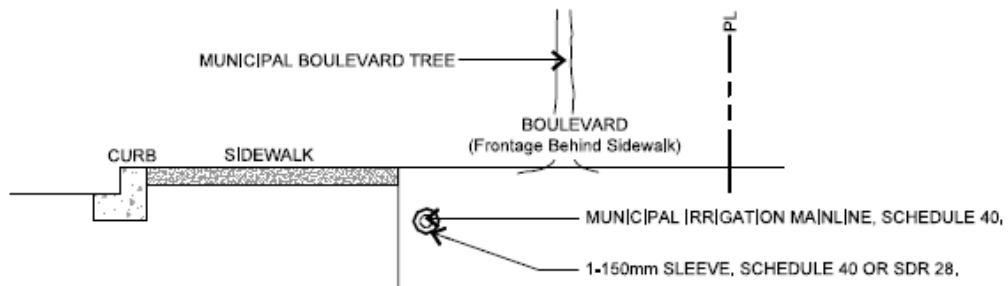

SECTION

MUNICIPAL IRRIGATION SLEEVING DETAIL
Frontage Behind Sidewalk (Mainline & Sleeving)



CITY OF LANGFORD
PARKS DEPARTMENT

DATE: 28-Feb-23	DRAWN: TMM	MMCD SS P2
SCALE: NTS	APPROVED: YN	

Last Revised: Bylaw 2103, February 2023

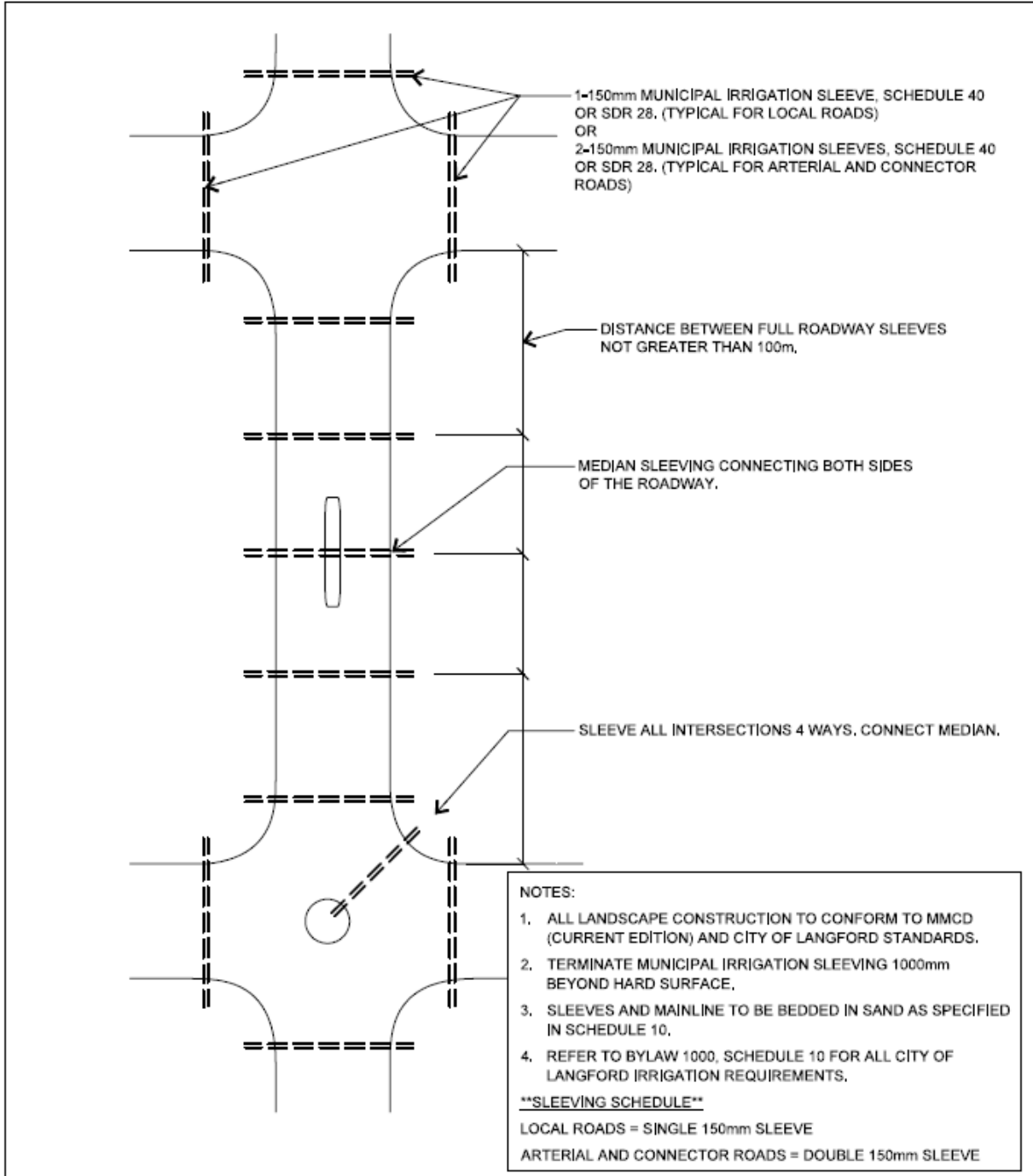

MUNICIPAL IRRIGATION SLEEVING DETAIL Typical Roadway Sleeving Layout	 CITY OF LANGFORD PARKS DEPARTMENT		MMCD SS P3
	DATE: 28-Feb-23	DRAWN: TMM	
SCALE: NTS			

Last Revised: Bylaw 2103, February 2023

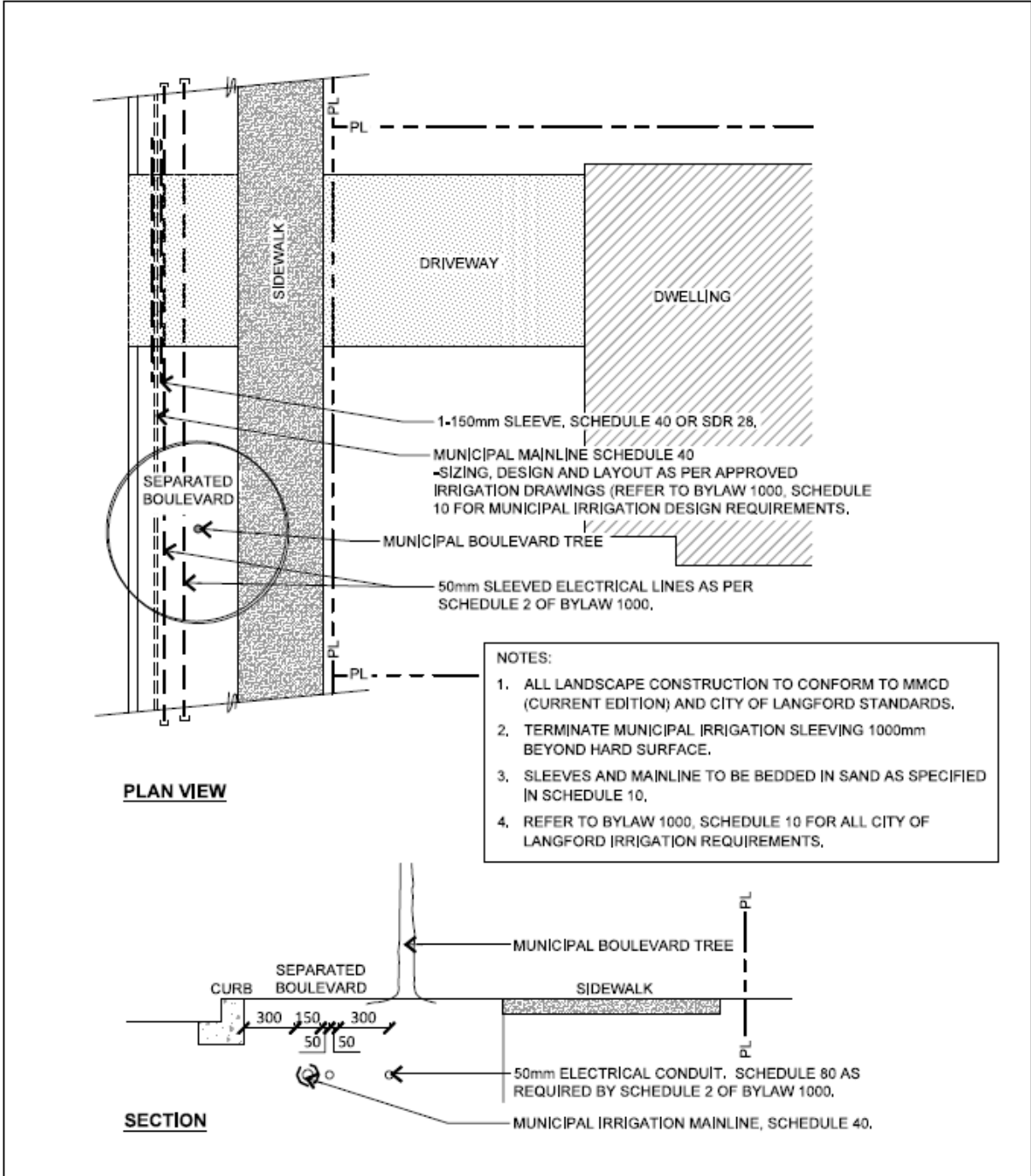

MUNICIPAL IRRIGATION SLEEVING DETAIL Separated Boulevard (Line Assignment)	 CITY OF LANGFORD PARKS DEPARTMENT		MMCD SS P4
	DATE: 28-Feb-23	DRAWN: TMM	
	SCALE: NTS	APPROVED: YN	

Last Revised: Bylaw 2103, February 2023

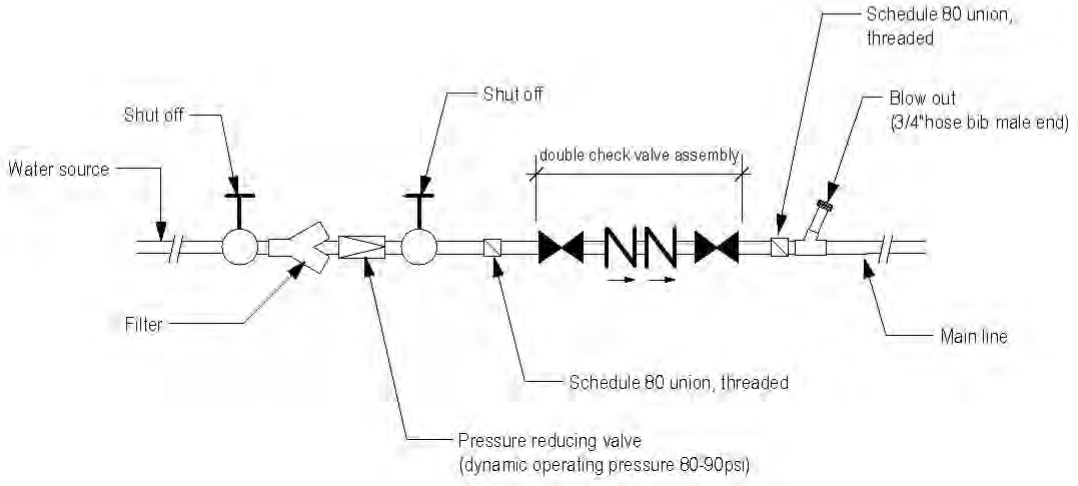

CROSS SECTION

WATER CONNECTION
Typical Installation section



CITY OF LANGFORD
PARKS DEPARTMENT.

DATE: 25/AUGUST/09	DRAWN: DE	DWG No. P5
SCALE: N.T.S.	APPROVED:	

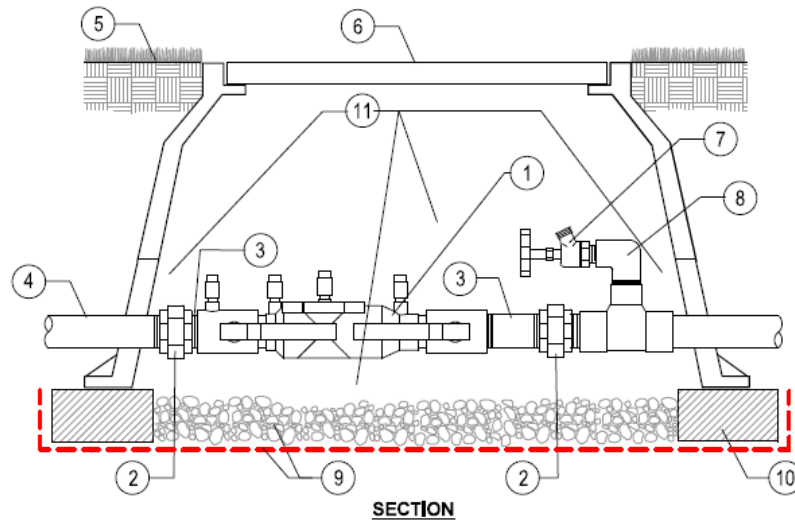

LEGEND:

- ① WATTS 007 DCVA.
- ② SCH80 UNION (INLET AND OUTLET).
- ③ BRASS NIPPLE BETWEEN UNION AND DEVICE.
- ④ MAINLINE FROM METRE.
- ⑤ FINISH GRADE/TOP OF MULCH.
- ⑥ VALVE BOX WITH COVER: AS PER SPEC.
- ⑦ INSTALL IMMEDIATELY DOWNSTREAM OF BACKFLOW DEVICE A 3/4" HOSE-BIB FOR WINTERIZING.
- ⑧ SCH 40 PVC T X T 90° STREET ELL. MARLEX STREET ELBOWS ARE NOT TO BE USED.
- ⑨ PEA GRAVEL - MIN. 6" DEEP. MIN. 6" DEEP ENCLOSED IN LANDSCAPE CLOTH TO PROTECT FROM DIRT.
- ⑩ BRICK (1 OF 4).
- ⑪ ALLOW SUFFICIENT ROOM ON ALL SIDES OF DEVICE FOR PROPER MAINTENANCE.

NOTES:

- 1. REFER TO PRODUCT LITERATURE FOR ADDITIONAL INSTALLATION AND ADJUSTMENT INFORMATION.
- 2. TEFLON TAPE ALL THREADED JOINTS.
- 3. INSTALLATION TO BE COMPLETED IN ACCORDANCE WITH MANUFACTURER'S SPECIFICATIONS.
- 4. DO NOT SCALE DRAWING.
- 5. THIS DRAWING IS INTENDED FOR USE BY ARCHITECTS, ENGINEERS, CONTRACTORS, CONSULTANTS AND DESIGN PROFESSIONALS FOR PLANNING PURPOSES ONLY. THIS DRAWING MAY NOT BE USED FOR CONSTRUCTION.
- 6. ALL INFORMATION CONTAINED HEREIN WAS CURRENT AT THE TIME OF DEVELOPMENT BUT MUST BE REVIEWED AND APPROVED BY THE PRODUCT MANUFACTURER TO BE CONSIDERED ACCURATE

IRRIGATION DETAIL
DCVA c/w HOSE-BIB



CITY OF LANGFORD
PARKS DEPARTMENT

DATE:	28-Feb-23	DRAWN:	TMM
SCALE:	NTS	APPROVED:	YN
			MMCD SS P5(a)

Last Revised: Bylaw 2103, February 2023

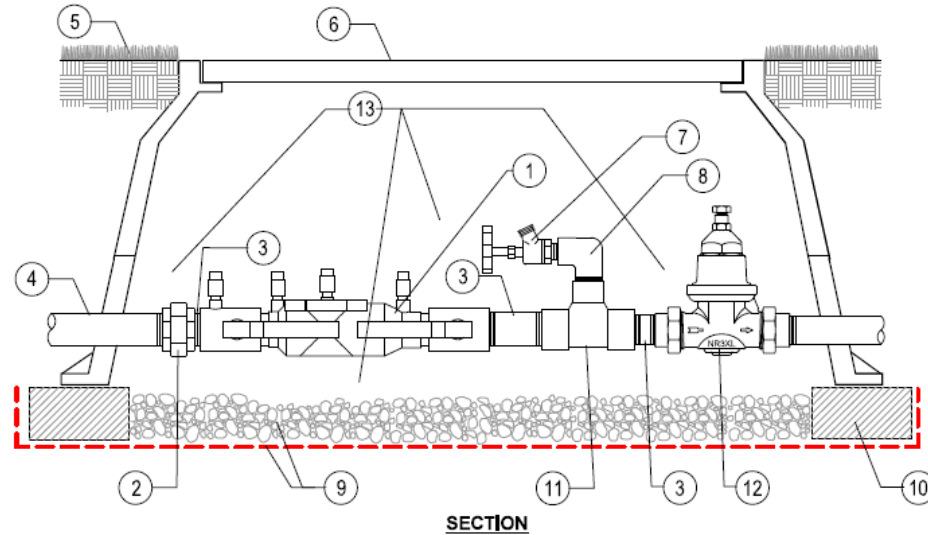

LEGEND:

- ① WATTS 007 DCVA.
- ② SCH80 UNION (INLET).
- ③ BRASS NIPPLE BETWEEN UNION AND DEVICE.
- ④ MAINLINE FROM METRE AND ISOLATION VALVE.
- ⑤ FINISH GRADE/TOP OF MULCH.
- ⑥ VALVE BOX WITH COVER: AS PER SPEC.
- ⑦ INSTALL IMMEDIATELY DOWNSTREAM OF BACKFLOW DEVICE A 3/4" HOSE-BIB FOR WINTERIZING.
- ⑧ SCH 40 PVC T X T 90° STREET ELL.
MARLEX STREET ELBOWS ARE NOT TO BE USED.
- ⑨ PEA GRAVEL - MIN. 6" DEEP. MIN. 6" DEEP ENCLOSED IN LANDSCAPE CLOTH TO PROTECT FROM DIRT.
- ⑩ BRICK (1 OF 4).
- ⑪ THREADED BRASS TEE SIZED TO DCVA. REDUCE OUTLET TO 3/4" IF NECESSARY TO ACCEPT 3/4" HOSE-BIB.
- ⑫ ADJUSTABLE BRASS PRESSURE REDUCING VALVE, ZURN NR3XL OR EQUIVALENT.
- ⑬ ALLOW SUFFICIENT ROOM ON ALL SIDES OF DEVICE FOR PROPER MAINTENANCE.

NOTES:

- 1. REFER TO PRODUCT LITERATURE FOR ADDITIONAL INSTALLATION AND ADJUSTMENT INFORMATION.
- 2. TEFLON TAPE ALL THREADED JOINTS.
- 3. INSTALLATION TO BE COMPLETED IN ACCORDANCE WITH MANUFACTURER'S SPECIFICATIONS.
- 4. DO NOT SCALE DRAWING.
- 5. THIS DRAWING IS INTENDED FOR USE BY ARCHITECTS, ENGINEERS, CONTRACTORS, CONSULTANTS AND DESIGN PROFESSIONALS FOR PLANNING PURPOSES ONLY. THIS DRAWING MAY NOT BE USED FOR CONSTRUCTION.
- 6. ALL INFORMATION CONTAINED HEREIN WAS CURRENT AT THE TIME OF DEVELOPMENT BUT MUST BE REVIEWED AND APPROVED BY THE PRODUCT MANUFACTURER TO BE CONSIDERED ACCURATE

IRRIGATION DETAIL
DCVA c/w HOSE-BIB & PRV



CITY OF LANGFORD
PARKS DEPARTMENT

DATE: 28-Feb-23	DRAWN: TMM	MMCD SS P5(b)
SCALE: NTS	APPROVED: YN	

Last Revised: Bylaw 2103, February 2023

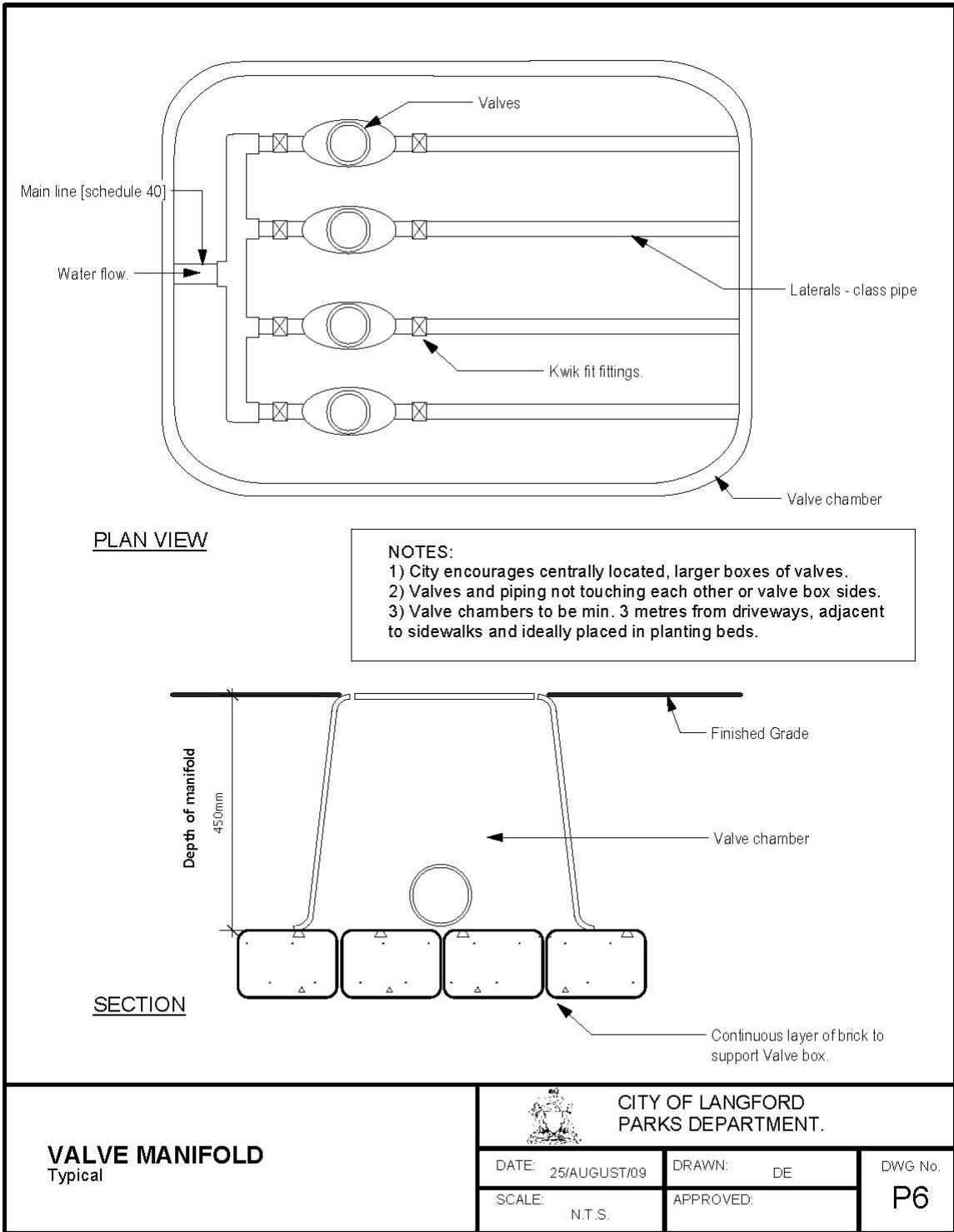

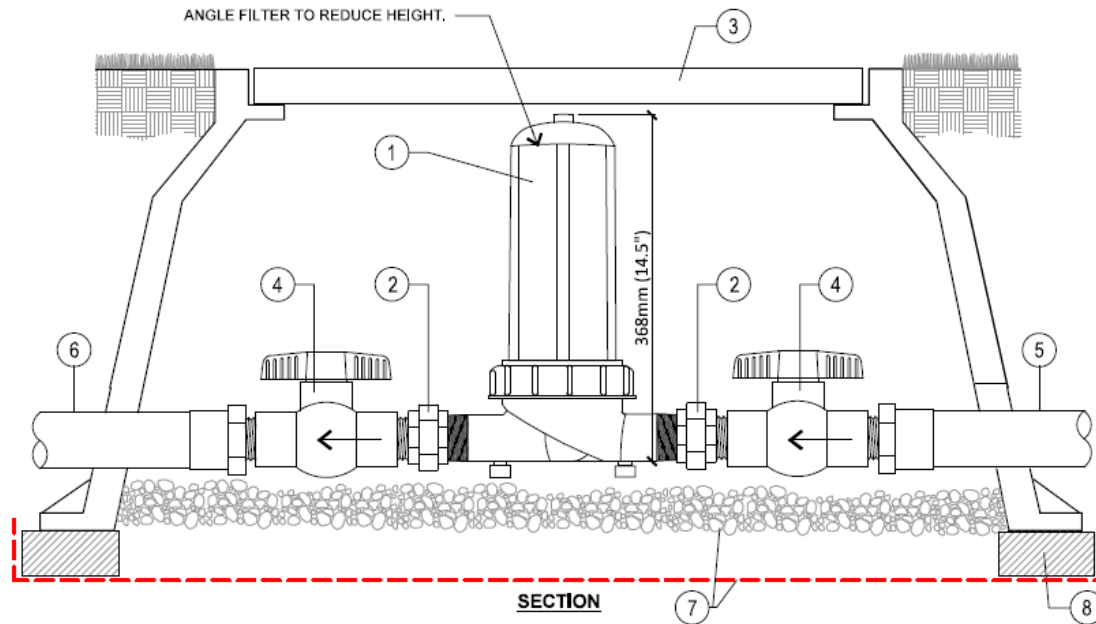

LEGEND:

- ① NETAFIM - 1.5" DISC FILTER MODEL # DF150S-080 - 80 MESH YELLOW DISK.
- ② SCHEDULE 80 PVC UNION, (INLET AND OUTLET).
- ③ VALVE BOX WITH COVER: NDS 13"W X 24"L X 15"D OR APPROVED EQUAL.
- ④ ISOLATION VALVES SHOULD BE INSTALLED UP AND DOWN STREAM TO ASSIST WITH CLEANING.
- ⑤ MAINLINE FROM POC, DCVA AND BLOWOUT.
- ⑥ MAINLINE TO ZONE VALVES.
- ⑦ PEA GRAVEL - MIN, 6" DEEP, MIN, 6" DEEP ENCLOSED IN LANDSCAPE CLOTH TO PROTECT FROM DIRT.
- ⑧ BRICK (1 OF 4).

DO NOT INSTALL WHEN TOTAL DRIP LINE EXCEEDS 500M.
INSTALL 2" FILTER (DETAIL P6b) FOR OVER 500M.

NOTES:

- 1. REFER TO PRODUCT LITERATURE FOR ADDITIONAL INSTALLATION AND ADJUSTMENT INFORMATION.
- 2. TEFLON TAPE ALL THREADED JOINTS.
- 3. INSTALLATION TO BE COMPLETED IN ACCORDANCE WITH MANUFACTURER'S SPECIFICATIONS.
- 4. DO NOT SCALE DRAWING.
- 5. THIS DRAWING IS INTENDED FOR USE BY ARCHITECTS, ENGINEERS, CONTRACTORS, CONSULTANTS AND DESIGN PROFESSIONALS FOR PLANNING PURPOSES ONLY. THIS DRAWING MAY NOT BE USED FOR CONSTRUCTION.
- 6. ALL INFORMATION CONTAINED HEREIN WAS CURRENT AT THE TIME OF DEVELOPMENT BUT MUST BE REVIEWED AND APPROVED BY THE PRODUCT MANUFACTURER TO BE CONSIDERED ACCURATE

IRRIGATION DETAIL FILTER 1.5"	 CITY OF LANGFORD PARKS DEPARTMENT	
	DATE: 28-Feb-23	DRAWN: TMM
SCALE: NTS	APPROVED: YN	

Last Revised: Bylaw 2103, February 2023

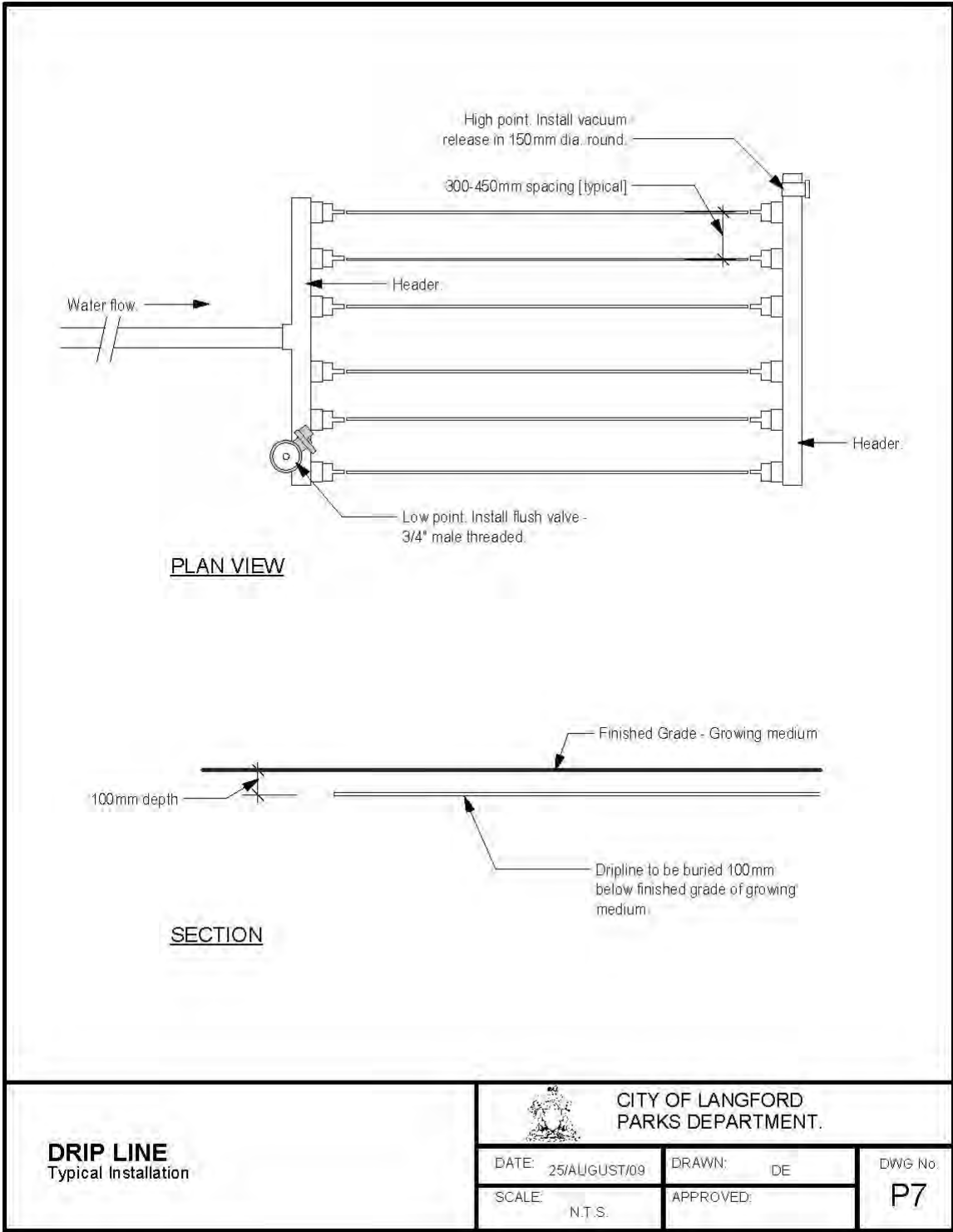

DRIP LINE
Typical Installation



CITY OF LANGFORD
PARKS DEPARTMENT.

DATE: 25/AUGUST/09

DRAWN: DE

DWG No.

SCALE: N.T.S.

APPROVED:

P7

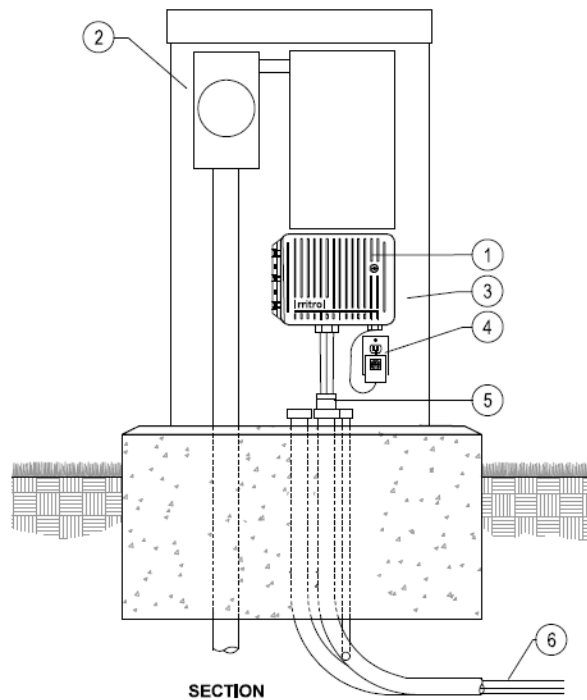

LEGEND:

- ① IRRITROL TOTAL CONTROL OR AS APPROVED BY THE DIRECTOR OF PARKS.
- ② METER BASE.
- ③ ALLOW MINIMUM 15" X 15" SPACE FOR CONTROLLER.
- ④ 120V RECEPTACLE.
- ⑤ CONDUIT FOR IRRIGATION WIRES, MINIMUM 2".
- ⑥ CONTROL VALVE, MASTER VALVE AND FLOW SENSOR WIRES

****CONTROLLER SHALL ALWAYS BE MOUNTED IN A KIOSK. IF IT IS THE OPINION OF THE DIRECTOR OF PARKS THAT A KIOSK IS IMPRACTICAL, THE CONTROLLER MAY BE MOUNTED TO A POST OR POLE.****

NOTES:

- 1. ALL ELECTRICAL WORK MUST CONFORM TO LOCAL CODES. REFER TO PRODUCT LITERATURE FOR ADDITIONAL INSTALLATION REQUIREMENTS.
- 2. INSTALLATION TO BE COMPLETED IN ACCORDANCE WITH MANUFACTURER'S SPECIFICATIONS.
- 3. DO NOT SCALE DRAWING.
- 4. THIS DRAWING IS INTENDED FOR USE BY ARCHITECTS, ENGINEERS, CONTRACTORS, CONSULTANTS AND DESIGN PROFESSIONALS FOR PLANNING PURPOSES ONLY. THIS DRAWING MAY NOT BE USED FOR CONSTRUCTION.
- 5. ALL INFORMATION CONTAINED HEREIN WAS CURRENT AT THE TIME OF DEVELOPMENT BUT MUST BE REVIEWED AND APPROVED BY THE PRODUCT MANUFACTURER TO BE CONSIDERED ACCURATE

**MAX. CONTROLLER DIMENSIONS
(6-24 ZONES OUTDOOR MODEL)**

- WIDTH - 10.50"
- HEIGHT - 8.50"
- DEPTH - 5.00"

ELECTRICAL SPECIFICATIONS:

- POWER SUPPLY VOLTAGE 120 VAC +/- 10%
- OUTPUT - 24 VAC - 1.67A

**IRRIGATION DETAIL
CONTROLLER LOCATED IN ELECTRICAL KIOSK**



CITY OF LANGFORD
PARKS DEPARTMENT

DATE: 28-Feb-23	DRAWN: TMM	MMCD SS P8(a)
SCALE: NTS	APPROVED: YN	

Last Revised: Bylaw 2103, February 2023

LIGHT POLE INSTALLATION

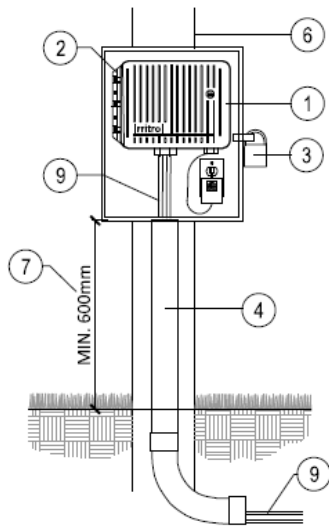

SECTION

SQUARE TUBING INSTALLATION

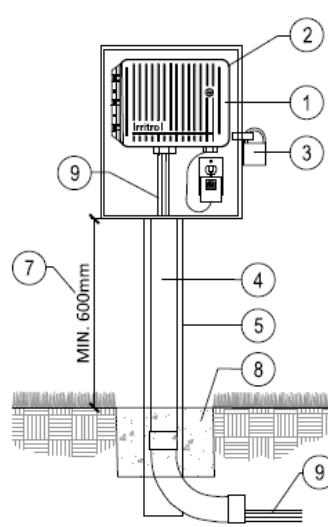

SECTION

LEGEND:

- ① IRRITROL TOTAL CONTROL OR AS APPROVED BY THE DIRECTOR OF PARKS,
- ② CONTROLLER CABINET TO BE LOCKABLE ALUMINUM, WEATHER PROOF, HINGE AND HASPED, MOUNTED SECURELY, ON ALL INSTALLATIONS, CONFIRM IF THE CABINET WILL BE POWDER COATED THE SAME COLOUR AS THE ADJACENT STREET LIGHT POLES. CABINET SIZE MUST BE SUFFICIENT TO HOUSE THE CONTROLLER AND ANY ACCESSORIES.
- ③ LOCKS SUPPLIED BY THE CITY IF LOCATED IN CABINET.
- ④ CONDUIT FOR IRRIGATION WIRES, MINIMUM 2".
- ⑤ IF INSTALLED IN BOULEVARD CABINET IS TO BE MOUNTED TO 100MM SQUARE TUBING SET IN CONCRETE BASE, POWDER COATED COLOUR TO MATCH CABINET.
- ⑥ LOCATION OF POST TO BE 900MM FROM SIDEWALK, 3M MINIMUM AWAY FROM INTERSECTIONS AND PREFERABLY WITHIN SHRUB BEDS.
- ⑦ CONFIRM CONTROLLER HEIGHT WITH THE DIRECTOR OF PARKS.
- ⑧ IF MOUNTED ON POST INSTALL IN CONCRETE BASE MINIMUM 600MM DEPTH.
- ⑨ CONTROL VALVE, MASTER VALVE AND FLOW SENSOR WIRES.

****CONTROLLER SHALL ALWAYS BE MOUNTED IN A KIOSK. IF IT IS THE OPINION OF THE DIRECTOR OF PARKS THAT A KIOSK IS IMPRACTICAL, THE CONTROLLER MAY BE MOUNTED TO A POST OR POLE.****

NOTES:

1. ALL ELECTRICAL WORK MUST CONFORM TO LOCAL CODES. REFER TO PRODUCT LITERATURE FOR ADDITIONAL INSTALLATION REQUIREMENTS.
2. INSTALLATION TO BE COMPLETED IN ACCORDANCE WITH MANUFACTURER'S SPECIFICATIONS.
3. DO NOT SCALE DRAWING.
4. THIS DRAWING IS INTENDED FOR USE BY ARCHITECTS, ENGINEERS, CONTRACTORS, CONSULTANTS AND DESIGN PROFESSIONALS FOR PLANNING PURPOSES ONLY. THIS DRAWING MAY NOT BE USED FOR CONSTRUCTION.
5. ALL INFORMATION CONTAINED HEREIN WAS CURRENT AT THE TIME OF DEVELOPMENT BUT MUST BE REVIEWED AND APPROVED BY THE PRODUCT MANUFACTURER TO BE CONSIDERED ACCURATE

**MAX. CONTROLLER DIMENSIONS
(6-24 ZONES OUTDOOR MODEL)**

- WIDTH - 10.50"
- HEIGHT - 8.50"
- DEPTH - 5.00"

ELECTRICAL SPECIFICATIONS:

- POWER SUPPLY VOLTAGE 120 VAC +/- 10%
- OUTPUT - 24 VAC - 1.67A

- CHECK DESIRED OPTION
- STREET LIGHT POLE
- STAND ALONE POST

**IRRIGATION DETAIL
CONTROLLER LOCATED ON POST / POLE**



**CITY OF LANGFORD
PARKS DEPARTMENT**

DATE: 28-Feb-23	DRAWN: TMM	MMCD SS P8(b)
SCALE: NTS	APPROVED: YN	

Last Revised: Bylaw 2103, February 2023

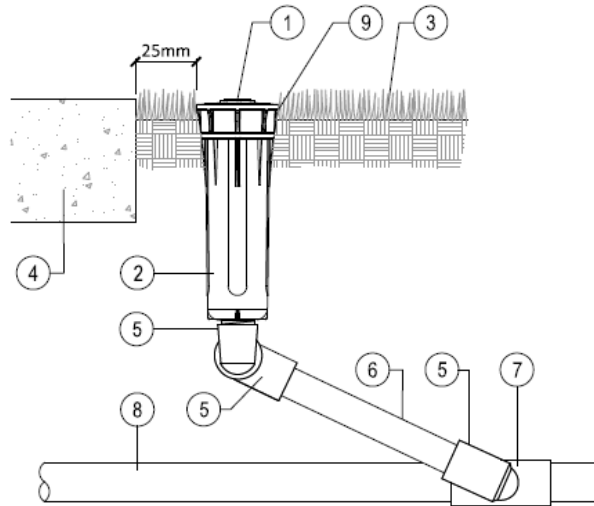

SECTION

- SELECT DESIRED NOZZLE
- PLASTIC PRECISION NOZZLE
- PLASTIC MPR NOZZLE
- ROTARY NOZZLE

- SELECT DESIRED SERIES
- STANDARD SERIES
- CV SERIES
- PRS SERIES
- PRS - CV SERIES

LEGEND:

- ① TORO PRECISION SPRAY NOZZLE UNLESS OTHERWISE NOTED ON DRAWING.
- ② IRRITROL I-PRO-400 POPUP. RAIN BIRD 1804 AS ALTERNATIVE.
- ③ FINISH GRADE.
- ④ CURB, SIDEWALK OR FOUNDATION.
- ⑤ SCH 40 PVC THREAD X THREAD 90° STREET ELL. MARLEX STREET ELBOWS ARE NOT TO BE USED UNLESS APPROVED.
- ⑥ PVC SCHEDULE 80 NIPPLE (6" MIN LENGTH).
- ⑦ LATERAL LINE PIPE FITTING (TEE OR ELBOW).
- ⑧ LATERAL LINE PIPING.
- ⑨ WHEN USING PRECISION NOZZLES ELEVATE HEADS 1/2" IN TURF AND 1" IN BEDS TO ELIMINATE BACK SIPHONAGE OF DEBRIS. DO NOT INSTALL BELOW SOIL OR MULCH LEVEL.

NOTES:

- 1. REFER TO PRODUCT LITERATURE FOR ADDITIONAL INSTALLATION AND ADJUSTMENT INFORMATION.
- 2. TEFLON TAPE ALL THREADED JOINTS.
- 3. INSTALLATION TO BE COMPLETED IN ACCORDANCE WITH MANUFACTURER'S SPECIFICATIONS.
- 4. DO NOT SCALE DRAWING.
- 5. THIS DRAWING IS INTENDED FOR USE BY ARCHITECTS, ENGINEERS, CONTRACTORS, CONSULTANTS AND DESIGN PROFESSIONALS FOR PLANNING PURPOSES ONLY. THIS DRAWING MAY NOT BE USED FOR CONSTRUCTION.
- 6. ALL INFORMATION CONTAINED HEREIN WAS CURRENT AT THE TIME OF DEVELOPMENT BUT MUST BE REVIEWED AND APPROVED BY THE PRODUCT MANUFACTURER TO BE CONSIDERED ACCURATE

IRRIGATION DETAIL
SPRAY - 4" POPUP



CITY OF LANGFORD
PARKS DEPARTMENT

DATE: 28-Feb-23	DRAWN: TMM	MMCD SS P9
SCALE: NTS	APPROVED: YN	

Last Revised: Bylaw 2103, February 2023

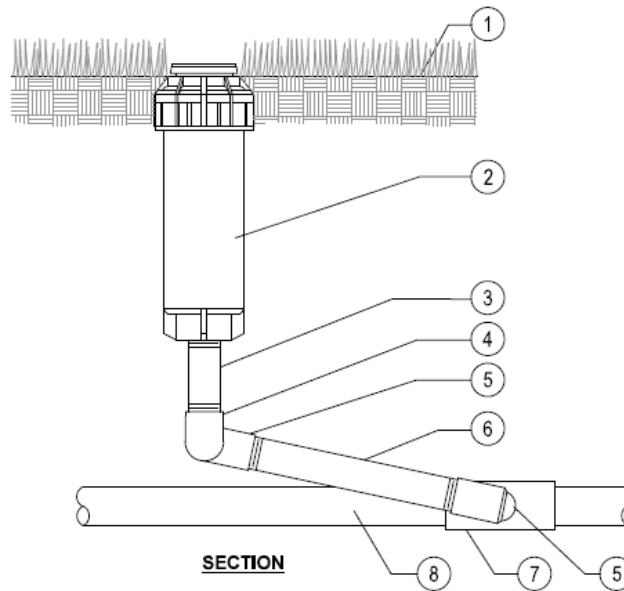

LEGEND:

- ① FINISH GRADE/TOP OF MULCH.
- ② ROTOR POP-UP SPRINKLER: RAIN BIRD - 5004 (SEE OPTIONS)
- ③ (OPTIONAL) PVC SCH 80 NIPPLE (LENGTH AS REQUIRED).
- ④ PVC SCH 40 ELL OR STREET ELL.
- ⑤ PVC SCH 40 STREET ELL. MARLEX STREET ARE NOT TO BE USED.
- ⑥ PVC SCH 80 NIPPLE (MINIMUM 6").
- ⑦ PVC SCH 40 TEE OR ELL.
- ⑧ PVC LATERAL PIPE.

NOTES:

- 1. REFER TO PRODUCT LITERATURE FOR ADDITIONAL INSTALLATION AND ADJUSTMENT INFORMATION.
- 2. TEFLON TAPE ALL THREADED JOINTS.
- 3. INSTALLATION TO BE COMPLETED IN ACCORDANCE WITH MANUFACTURER'S SPECIFICATIONS.
- 4. DO NOT SCALE DRAWING.
- 5. THIS DRAWING IS INTENDED FOR USE BY ARCHITECTS, ENGINEERS, CONTRACTORS, CONSULTANTS AND DESIGN PROFESSIONALS FOR PLANNING PURPOSES ONLY. THIS DRAWING MAY NOT BE USED FOR CONSTRUCTION.
- 6. ALL INFORMATION CONTAINED HEREIN WAS CURRENT AT THE TIME OF DEVELOPMENT BUT MUST BE REVIEWED AND APPROVED BY THE PRODUCT MANUFACTURER TO BE CONSIDERED ACCURATE

IRRIGATION DETAIL
ROTOR - RAIN BIRD 5004



CITY OF LANGFORD
 PARKS DEPARTMENT

DATE: 28-Feb-23	DRAWN: TMM	MMCD SS P10
SCALE: NTS	APPROVED: YN	

Last Revised: Bylaw 2103, February 2023

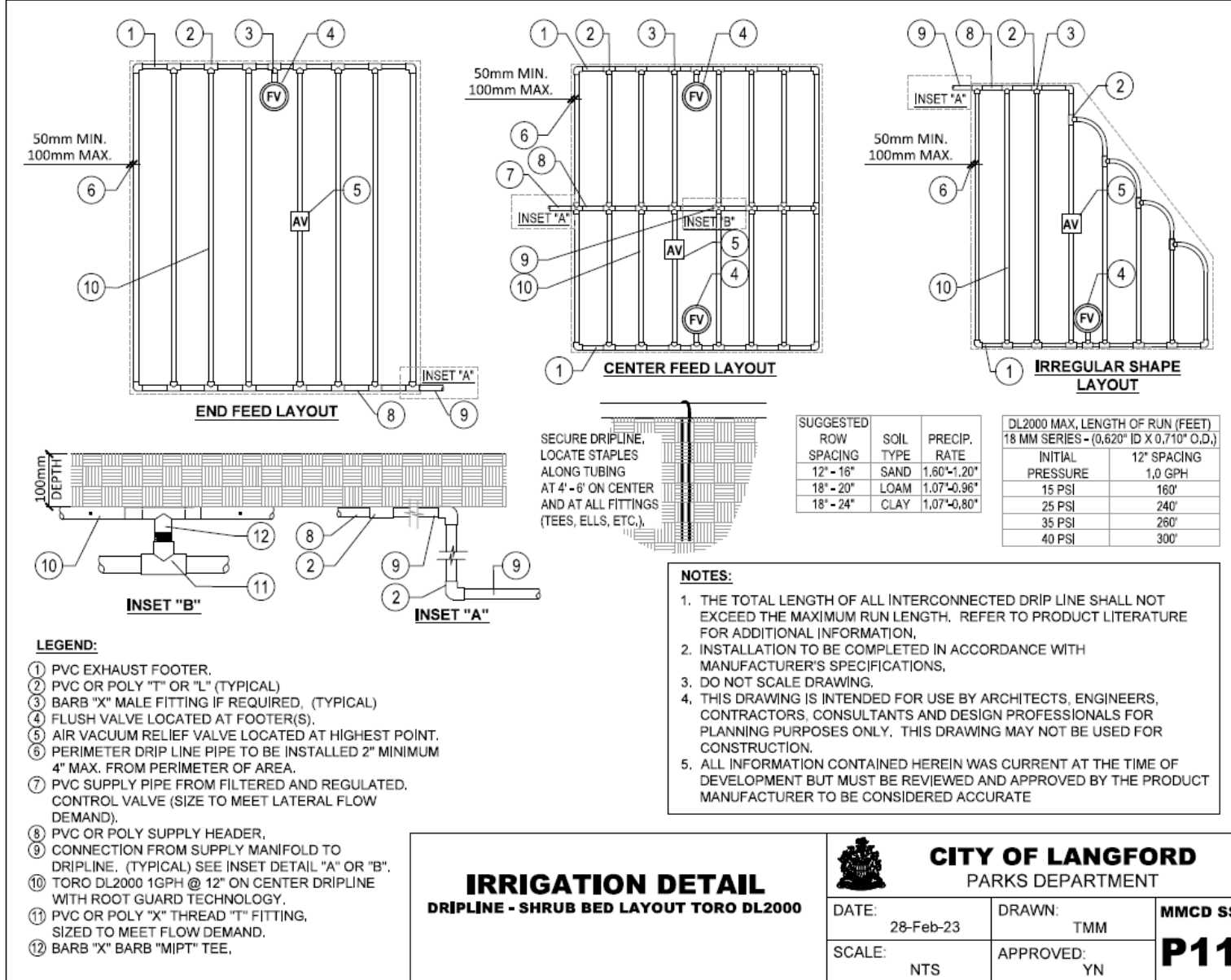

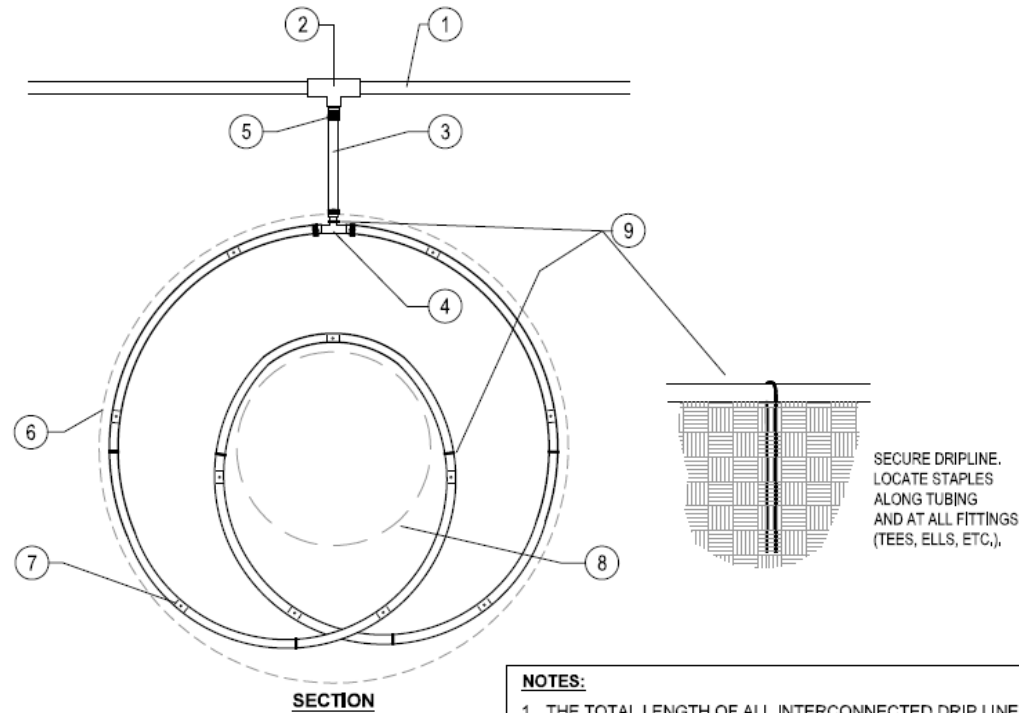

SECURE DRIPLINE.
LOCATE STAPLES
ALONG TUBING
AND AT ALL FITTINGS
(TEES, ELLS, ETC.),

SECTION

LEGEND:

- ① PVC LATERAL PIPE.
- ② PVC SCHEDULE 40 "T" OR "L".
- ③ 1/2 " POLYETHYLENE TUBING.
- ④ BARBED "T".
- ⑤ STAINLESS CRIMP CLAMP.
- ⑥ PROJECTED CANOPY LINE OF TREE.
- ⑦ TORO DL2000 DRIPLINE LATERAL, (RGP-412-05), DOUBLE LOOPED @ 4"DEPTH ROOT BALL.
- ⑧ WIRE STAKES LOCATED AT ALL FITTINGS AND HALFWAY
- ⑨ POINTS OF EACH DRIP RUN. MAX. 3' SPACING.

NOTES:

- 1. THE TOTAL LENGTH OF ALL INTERCONNECTED DRIP LINE SHALL NOT EXCEED THE MAXIMUM RUN LENGTH. REFER TO PRODUCT LITERATURE FOR ADDITIONAL INFORMATION.
- 2. INSTALLATION TO BE COMPLETED IN ACCORDANCE WITH MANUFACTURER'S SPECIFICATIONS.
- 3. DO NOT SCALE DRAWING.
- 4. THIS DRAWING IS INTENDED FOR USE BY ARCHITECTS, ENGINEERS, CONTRACTORS, CONSULTANTS AND DESIGN PROFESSIONALS FOR PLANNING PURPOSES ONLY. THIS DRAWING MAY NOT BE USED FOR CONSTRUCTION.
- 5. ALL INFORMATION CONTAINED HEREIN WAS CURRENT AT THE TIME OF DEVELOPMENT BUT MUST BE REVIEWED AND APPROVED BY THE PRODUCT MANUFACTURER TO BE CONSIDERED ACCURATE.

IRRIGATION DETAIL
DRIPLINE - TREE LAYOUT TORO DL2000



CITY OF LANGFORD
PARKS DEPARTMENT

DATE: 28-Feb-23	DRAWN: TMM	MMCD SS P12
SCALE: NTS	APPROVED: YN	

Last Revised: Bylaw 2103, February 2023

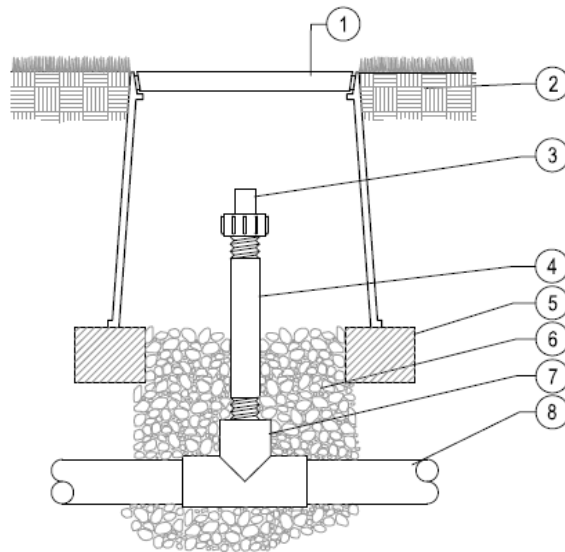

SECTION

LEGEND:

- ① 6" ROUND PLASTIC VALVE BOX.
- ② FINISH GRADE.
- ③ TORO DL2000 FLUSH VALVE(FCH-H-FIPT).
INSTALL 1 PER 10GPM FLOW PER ZONE.
- ④ 3/4" X 3" SCH, 80 NIPPLE.(HEIGHT MAY VARY DEPENDING
ON PIPE DEPTH).
- ⑤ BRICK SUPPORTS IF LOCATED IN HIGH TRAFFIC AREA.
- ⑥ PEA GRAVEL SUMP (6" DEEP).
- ⑦ PVC TEE IF LOCATED IN HEADER OR FOOTER. POLY
TEE IF LOCATED IN DRIP LINE.
- ⑧ PVC PIPE OR DRIP LINE.

NOTES:

- 1. USE ONE FLUSH VALVE FOR EVERY 10 GPM PER ZONE, LOCATE AT LOW POINTS. FLUSH RATE IS 0.8 GPM. FLUSH PRESSURE IS 2 PSI. REFER TO PRODUCT LITERATURE FOR ADDITIONAL INFORMATION.
- 2. INSTALLATION TO BE COMPLETED IN ACCORDANCE WITH MANUFACTURER'S SPECIFICATIONS.
- 3. DO NOT SCALE DRAWING.
- 4. THIS DRAWING IS INTENDED FOR USE BY ARCHITECTS, ENGINEERS, CONTRACTORS, CONSULTANTS AND DESIGN PROFESSIONALS FOR PLANNING PURPOSES ONLY. THIS DRAWING MAY NOT BE USED FOR CONSTRUCTION.
- 5. ALL INFORMATION CONTAINED HEREIN WAS CURRENT AT THE TIME OF DEVELOPMENT BUT MUST BE REVIEWED AND APPROVED BY THE PRODUCT MANUFACTURER TO BE CONSIDERED ACCURATE

IRRIGATION DETAIL
DRIPLINE -FLUSH VALVE



CITY OF LANGFORD
PARKS DEPARTMENT

DATE: 28-Feb-23	DRAWN: TMM	MMCD SS P13
SCALE: NTS	APPROVED: YN	

Last Revised: Bylaw 2103, February 2023

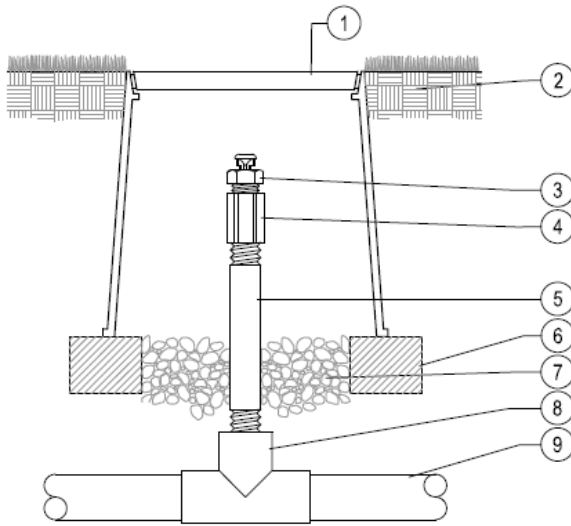

SECTION

LEGEND:

- ① 6" ROUND PLASTIC VALVE BOX.
- ② FINISH GRADE.
- ③ TORO DL2000 AIR/VACUUM RELIEF VALVE (YD-500-34).
INSTALL 1 PER 10GPM FLOW PER ZONE.
- ④ 1/2" FIPT COUPLING,
- ⑤ 1/2" X 3" SCH. 80 NIPPLE. (HEIGHT MAY VARY DEPENDING
ON PIPE DEPTH).
- ⑥ BRICK SUPPORTS IF LOCATED IN HIGH TRAFFIC AREA.
- ⑦ PEA GRAVEL SUMP (6" DEEP).
- ⑧ PVC TEE IF LOCATED IN HEADER OR FOOTER. POLY TEE
IF LOCATED IN DRIP LINE.
- ⑨ PVC PIPE OR DRIP LINE.

NOTES:

- 1. USE ONE AIR/RELIEF VALVE FOR EVERY 10 GPM PER ZONE. LOCATE AT HIGH POINTS. REFER TO PRODUCT LITERATURE FOR ADDITIONAL INFORMATION.
- 2. INSTALLATION TO BE COMPLETED IN ACCORDANCE WITH MANUFACTURER'S SPECIFICATIONS.
- 3. DO NOT SCALE DRAWING.
- 4. THIS DRAWING IS INTENDED FOR USE BY ARCHITECTS, ENGINEERS, CONTRACTORS, CONSULTANTS AND DESIGN PROFESSIONALS FOR PLANNING PURPOSES ONLY. THIS DRAWING MAY NOT BE USED FOR CONSTRUCTION.
- 5. ALL INFORMATION CONTAINED HEREIN WAS CURRENT AT THE TIME OF DEVELOPMENT BUT MUST BE REVIEWED AND APPROVED BY THE PRODUCT MANUFACTURER TO BE CONSIDERED ACCURATE

IRRIGATION DETAIL
DRIPLINE - AIR RELIEF



CITY OF LANGFORD
PARKS DEPARTMENT

DATE: 28-Feb-23	DRAWN: TMM	MMCD SS P14
SCALE: NTS	APPROVED: YN	

Last Revised: Bylaw 2103, February 2023

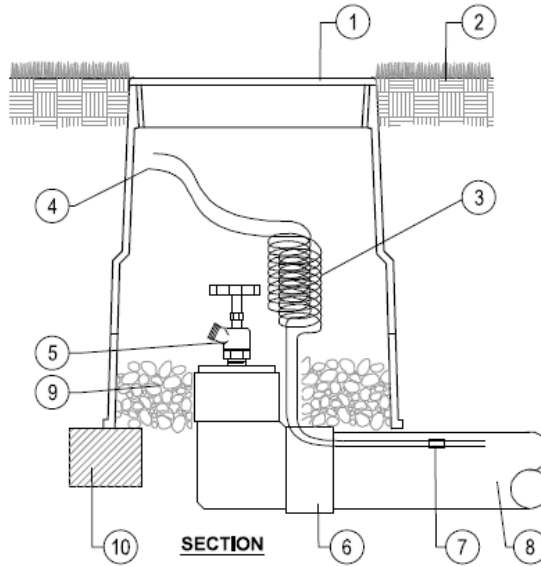

LEGEND:

- ① LOCKING VALVE BOX WITH COVER.
- ② FINISH GRADE.
- ③ BUNDLED COMMON AND CONTROL WIRE(S), MIN 30-INCH LINEAR LENGTH, COILED, QUANTITY AS PER DESIGN.
- ④ SEAL ENDS TO PREVENT CORROSION,
- ⑤ 1/2" HOSE-BIB TO ALLOW WATER TO BLOW OUT DURING WINTERIZING.
- ⑥ 90 DEGREE ELBOW REDUCED TO 1/2" FEMALE THREAD.
- ⑦ COMMON AND CONTROL WIRE(S) TO CONTROLLER LOCATION.
- ⑧ EXTENDED MAINLINE FOR FUTURE.
- ⑨ PEA GRAVEL - MIN, 6" DEEP,
- ⑩ BRICK SUPPORTS IF LOCATED IN HIGH TRAFFIC AREA.

NOTES:

- 1. ALL ELECTRICAL WORK MUST CONFORM TO LOCAL CODES, REFER TO PRODUCT LITERATURE FOR ADDITIONAL INSTALLATION REQUIREMENTS
- 2. DO NOT SCALE DRAWING,
- 3. THIS DRAWING IS INTENDED FOR USE BY ARCHITECTS, ENGINEERS, CONTRACTORS, CONSULTANTS AND DESIGN PROFESSIONALS FOR PLANNING PURPOSES ONLY. THIS DRAWING MAY NOT BE USED FOR CONSTRUCTION.
- 4. ALL INFORMATION CONTAINED HEREIN WAS CURRENT AT THE TIME OF DEVELOPMENT BUT MUST BE REVIEWED AND APPROVED BY THE PRODUCT MANUFACTURER TO BE CONSIDERED ACCURATE

IRRIGATION DETAIL
CAPPED MAIN / WIRE



CITY OF LANGFORD
PARKS DEPARTMENT

DATE: 28-Feb-23	DRAWN: TMM	MMCD SS P15
SCALE: NTS	APPROVED: YN	

Last Revised: Bylaw 2103, February 2023

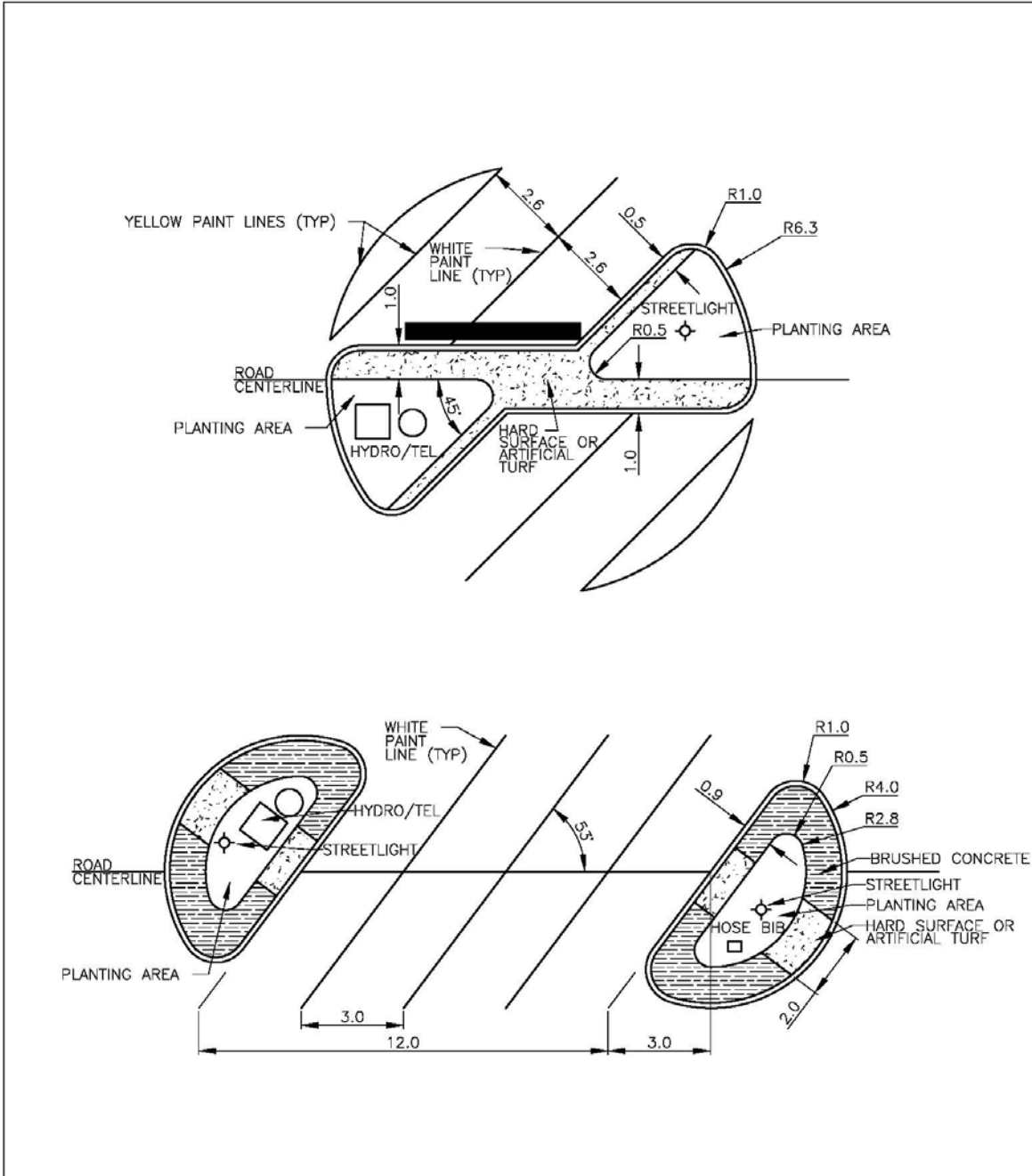

Turn Around Island Details



CITY OF LANGFORD
ENGINEERING DEPARTMENT

DATE: 19-Jan-10

DRAWN: TWB

MMCD SS

SCALE: NTS

APPROVED: MM

RS1

Last Revised: Bylaw 1817, February 2019

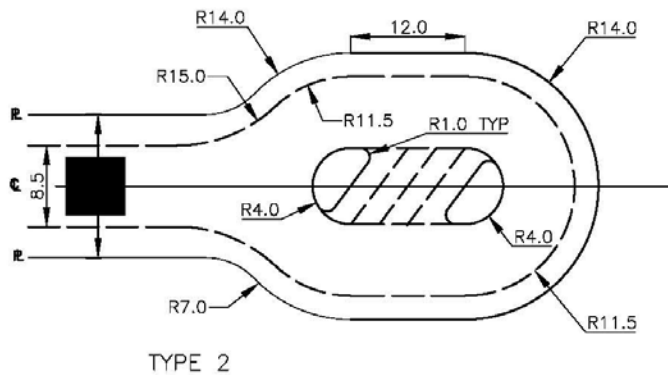
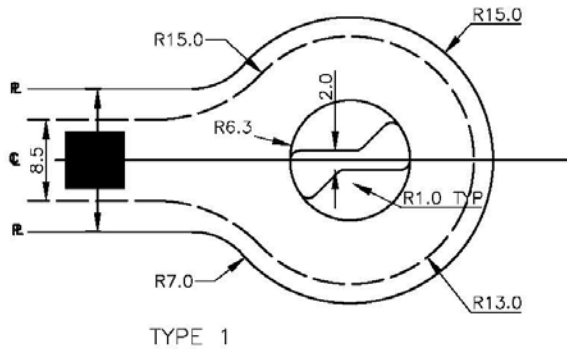

NOTES:

1. THESE STANDARDS APPLY TO TURN AROUNDS ON RESIDENTIAL ROADS FOR SINGLE FAMILY DWELLINGS
2. CHAINAGE FOR PROFILES SHALL BE ALONG THE CENTERLINE. SHOW SPOT ELEVATIONS ON GUTTER LINE AS WELL AS THE CENTERLINE PROFILE
3. FOR ISLAND DETAILS, REFER TO DRAWING RS1

Scale: 1:5

Turn Arouds



CITY OF LANGFORD
ENGINEERING DEPARTMENT

DATE:
19-Jan-10

DRAWN:
TWB

MMCD SS

SCALE:
NTS

APPROVED:
MM

RS2

Last Revised: Bylaw 1817, February 2019

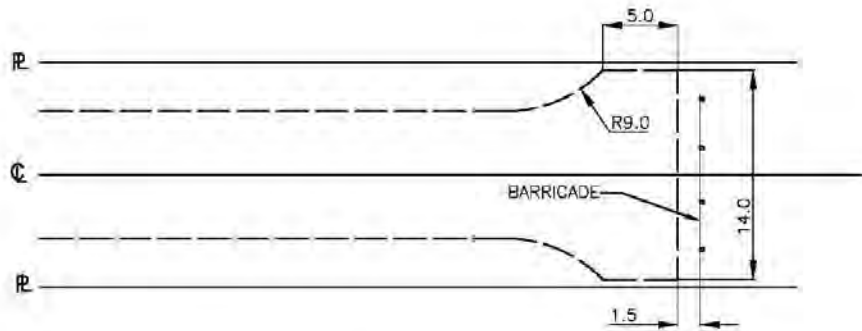

HAMMERHEAD TYPE

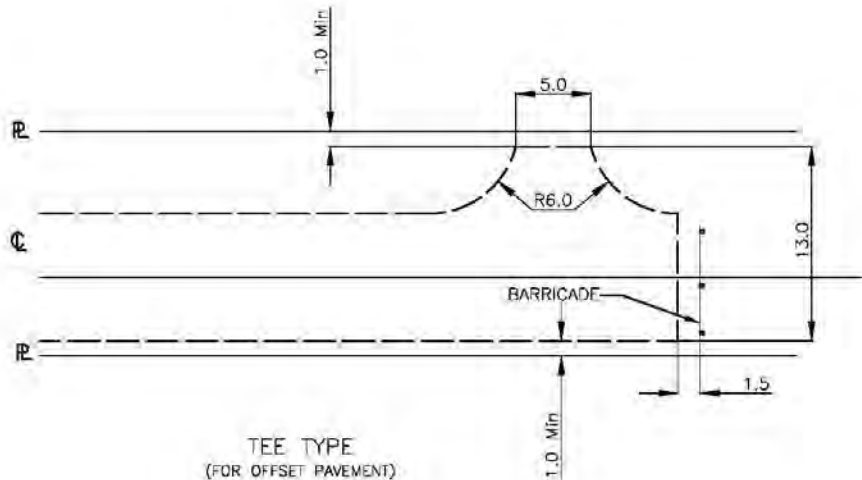

TEE TYPE
(FOR OFFSET PAVEMENT)

NOTE:

1: ALL TURN AROUNDS TO HAVE FULL WATER CONTROL FOR DRAINAGE

Temporary Turn Arouds



CITY OF LANGFORD
ENGINEERING DEPARTMENT

DATE: 19-Jan-10	DRAWN: TWB	DWG No.
SCALE: NTS	APPROVED: MM	RS3

Last Revised: Jan 19, 2010

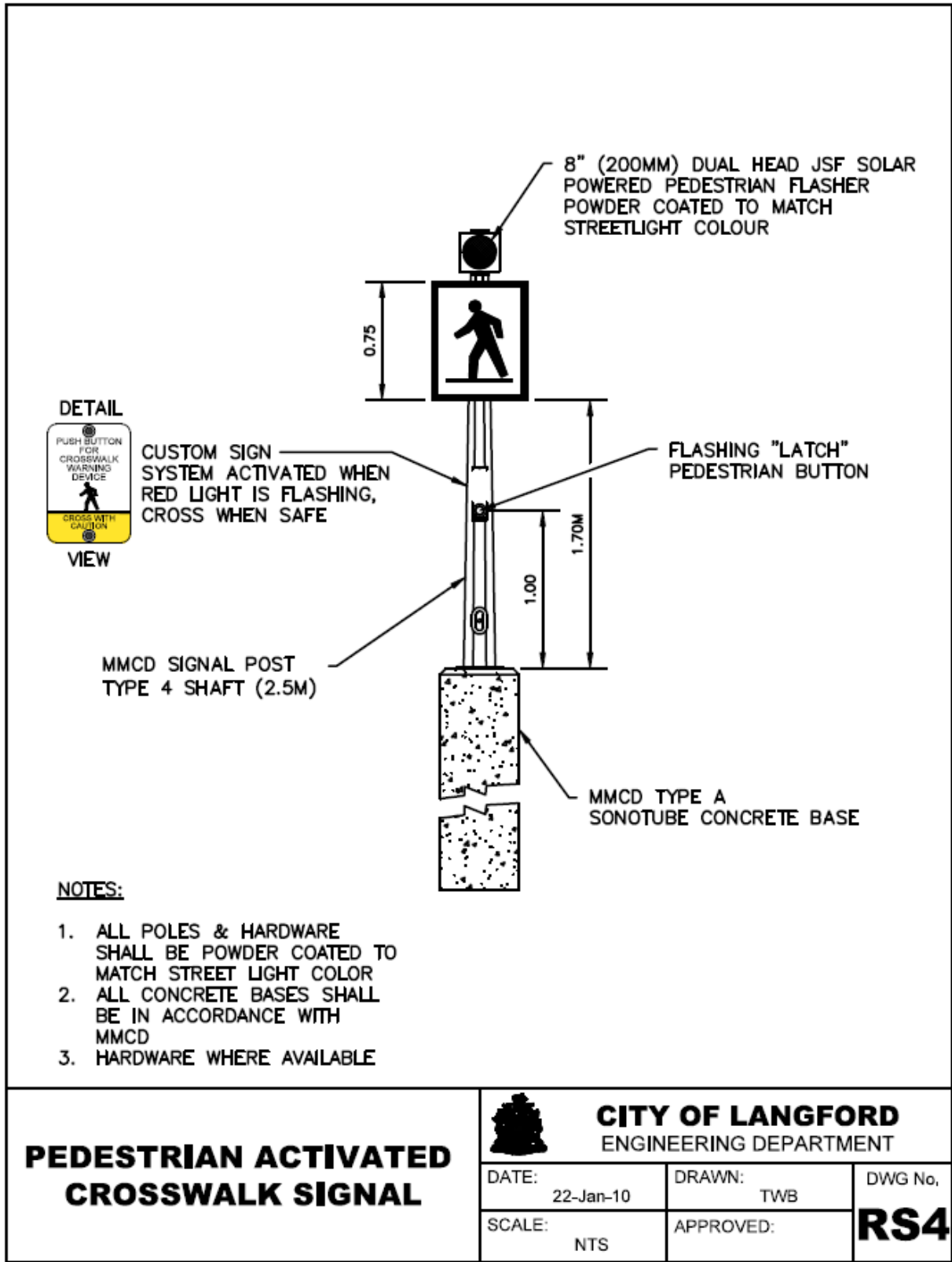

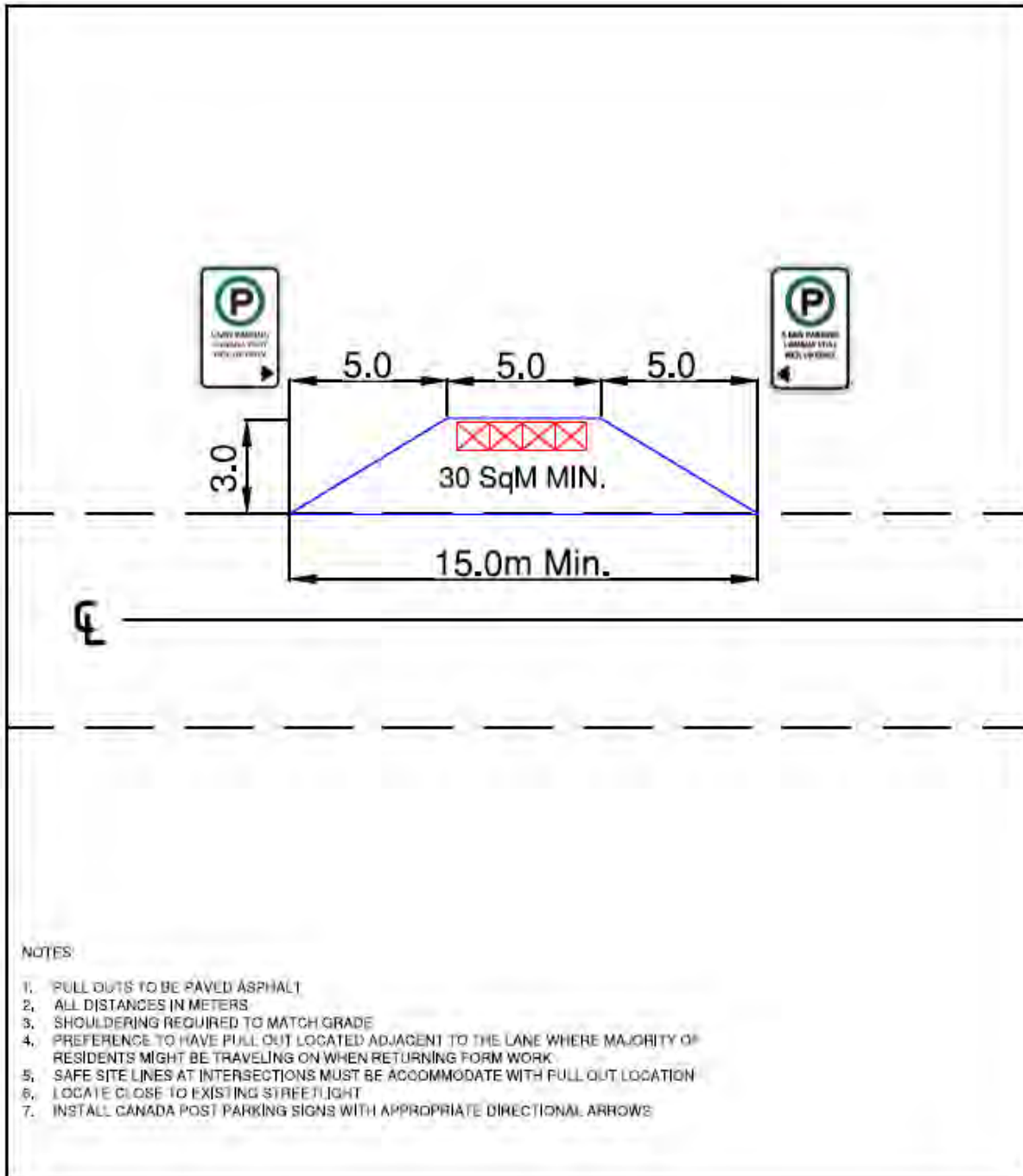

CANADA POST MAILBOX PULL OUTS	 CITY OF LANGFORD ENGINEERING DEPARTMENT		RS5
	DATE: MAY 29, 2023	DRAWN: MXW	
	SCALE: NTS	APPROVED: KB	

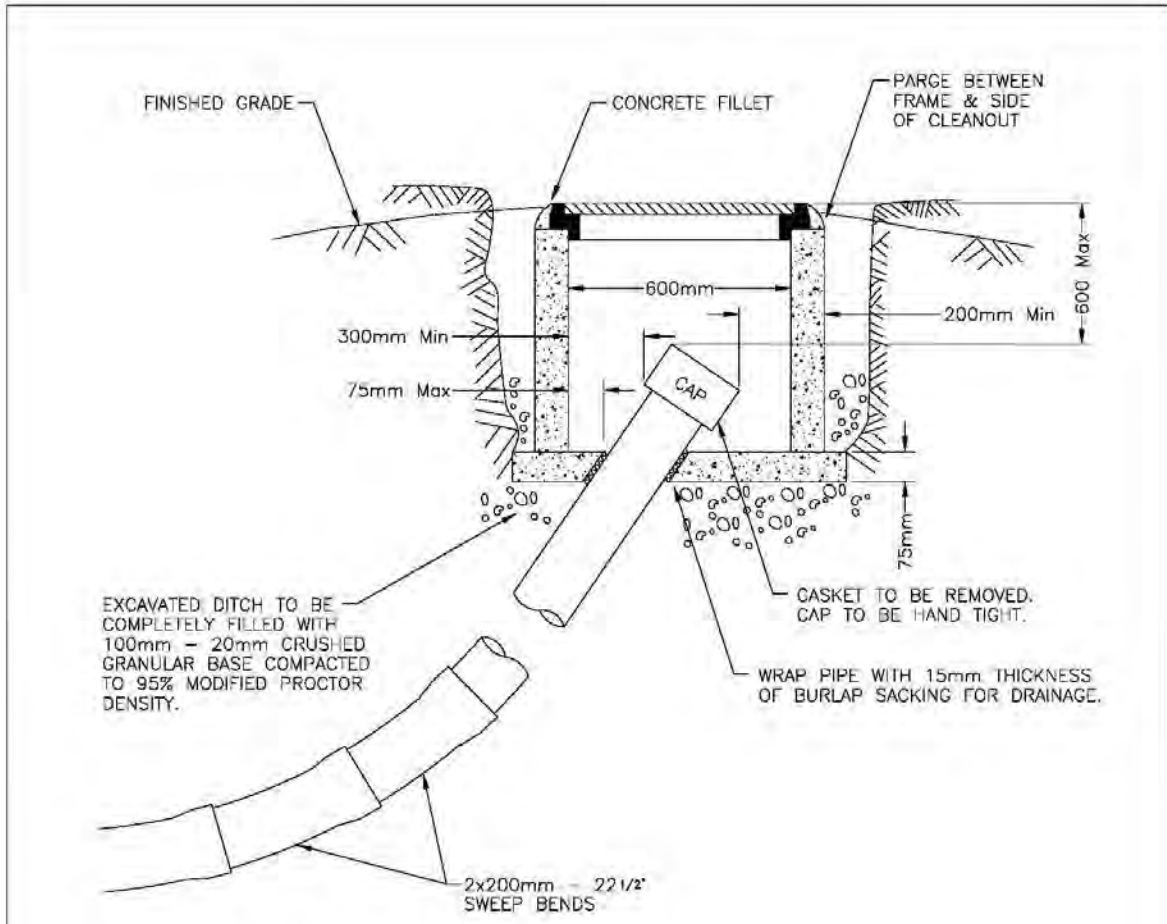

NOTES:

1. MANHOLE FRAME & COVER TO BE VICTORIA FOUNDRIES No.1D-28, OR APPROVED EQUAL AND MARKED LANGFORD SANITARY OR LANGFORD DRAIN.
2. TOP OF COVER TO BE 75mm± ABOVE EXISTING GROUND ON EASEMENTS OR BOULEVARDS WITH SOIL SLOPING AWAY FROM COVER.
3. TOP OF COVER TO BE FLUSH WITH SURFACE WHEN INSTALLED WITHIN TRAVELED PORTION OF ROAD.
4. EXCAVATION TO BE BACKFILLED WITH CLEAN GRAVEL AND COMPACTED UNDER CLEANOUT.
5. CAP TO BE INSTALLED WITHOUT GASKET.

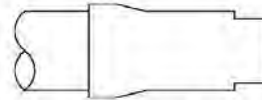

INCLUDE REDUCER IF DOWNSTREAM PIPE IS LARGER THAN 200mm.

SEWER CLEANOUT



**CITY OF LANGFORD
ENGINEERING DEPARTMENT**

DATE:
98/04/01

DRAWN:
GRH

SCALE:
NTS

APPROVED:

MMCD SS

S6

Last Revised: Oct 23, 2009

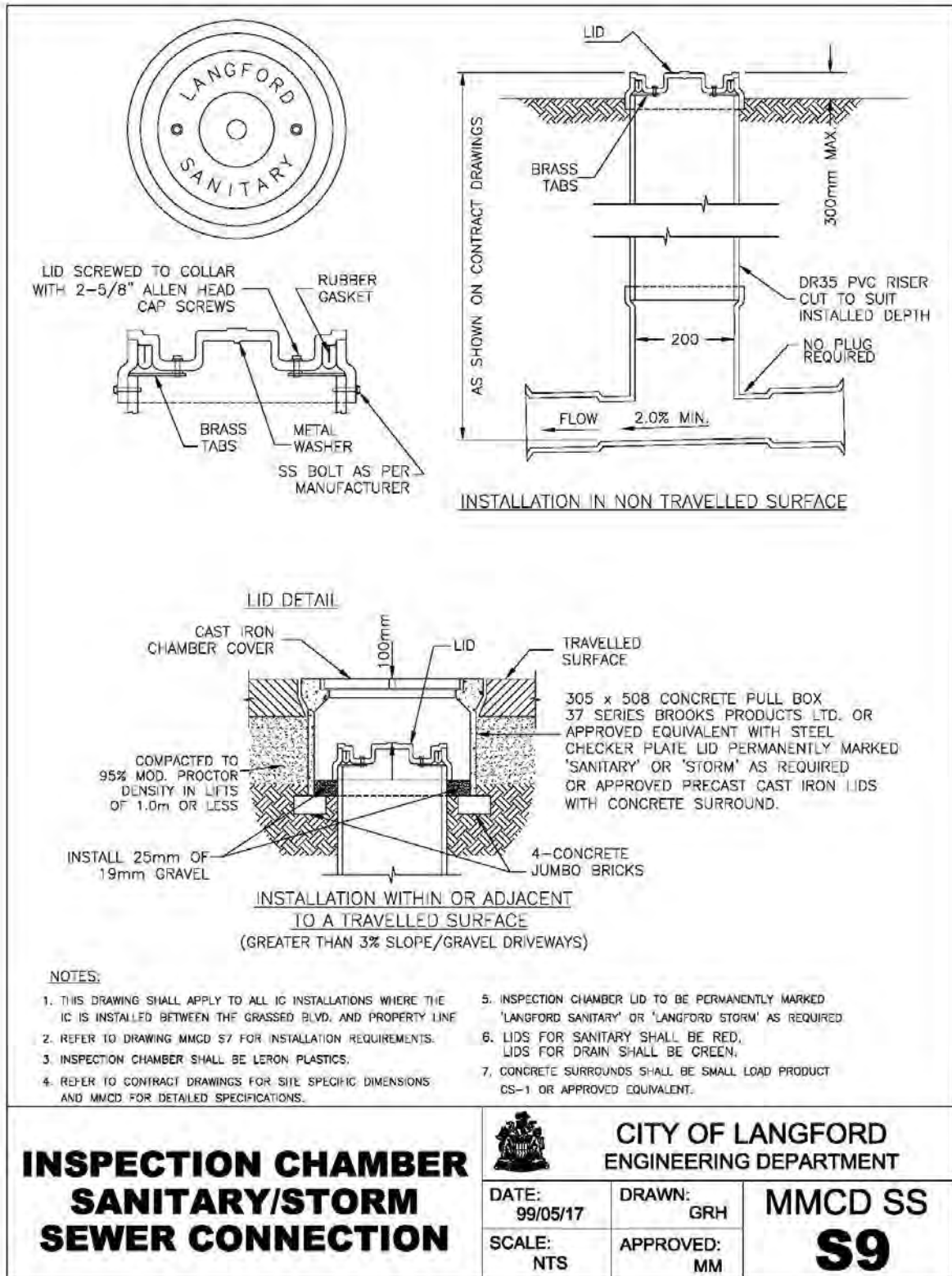

**INSPECTION CHAMBER
SANITARY/STORM
SEWER CONNECTION**



**CITY OF LANGFORD
ENGINEERING DEPARTMENT**

DATE:
99/05/17

DRAWN:
GRH

MMCD SS

SCALE:
NTS

APPROVED:
MM

S9

Last Revised: Bylaw 1817, February 2019

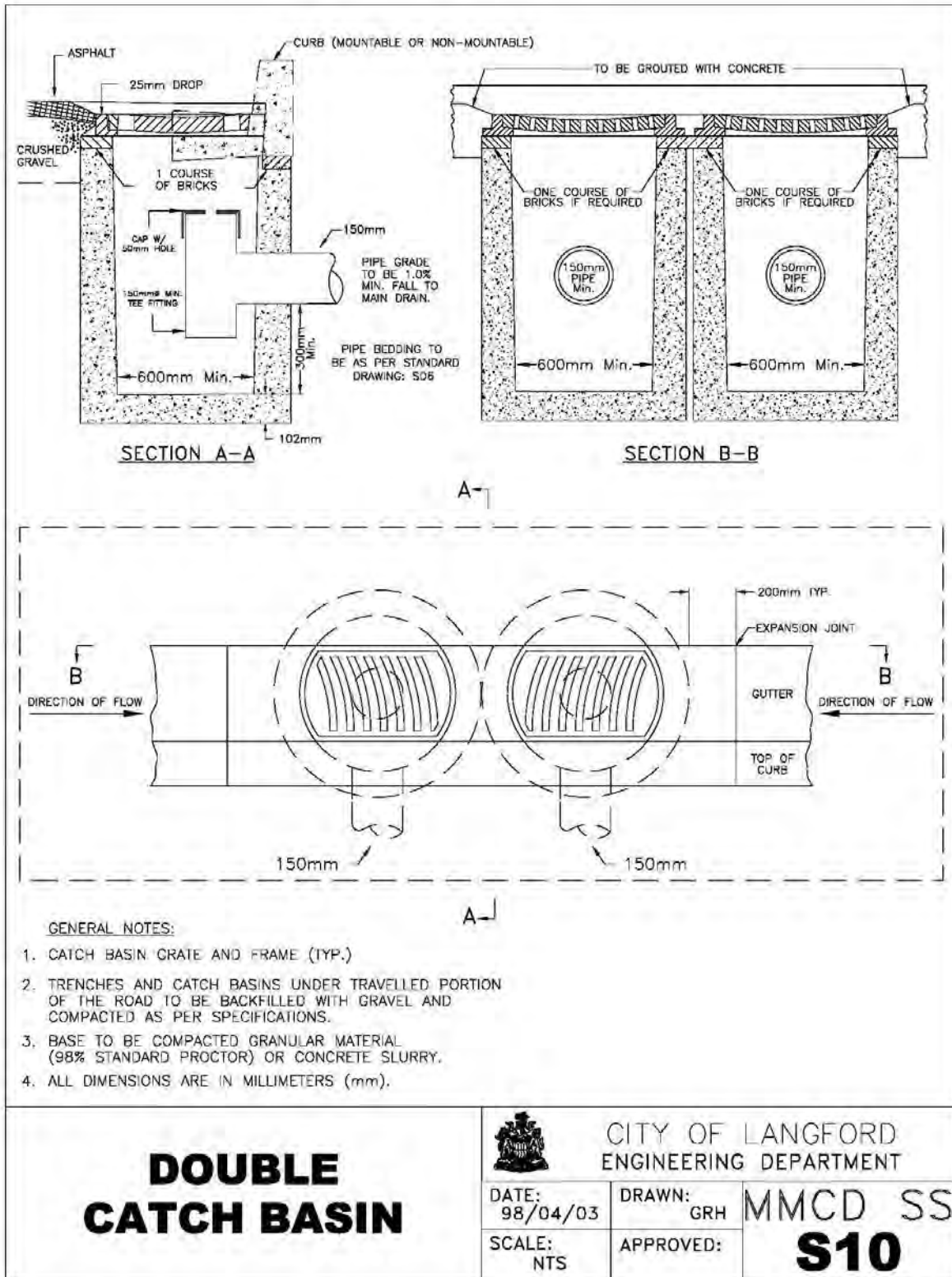

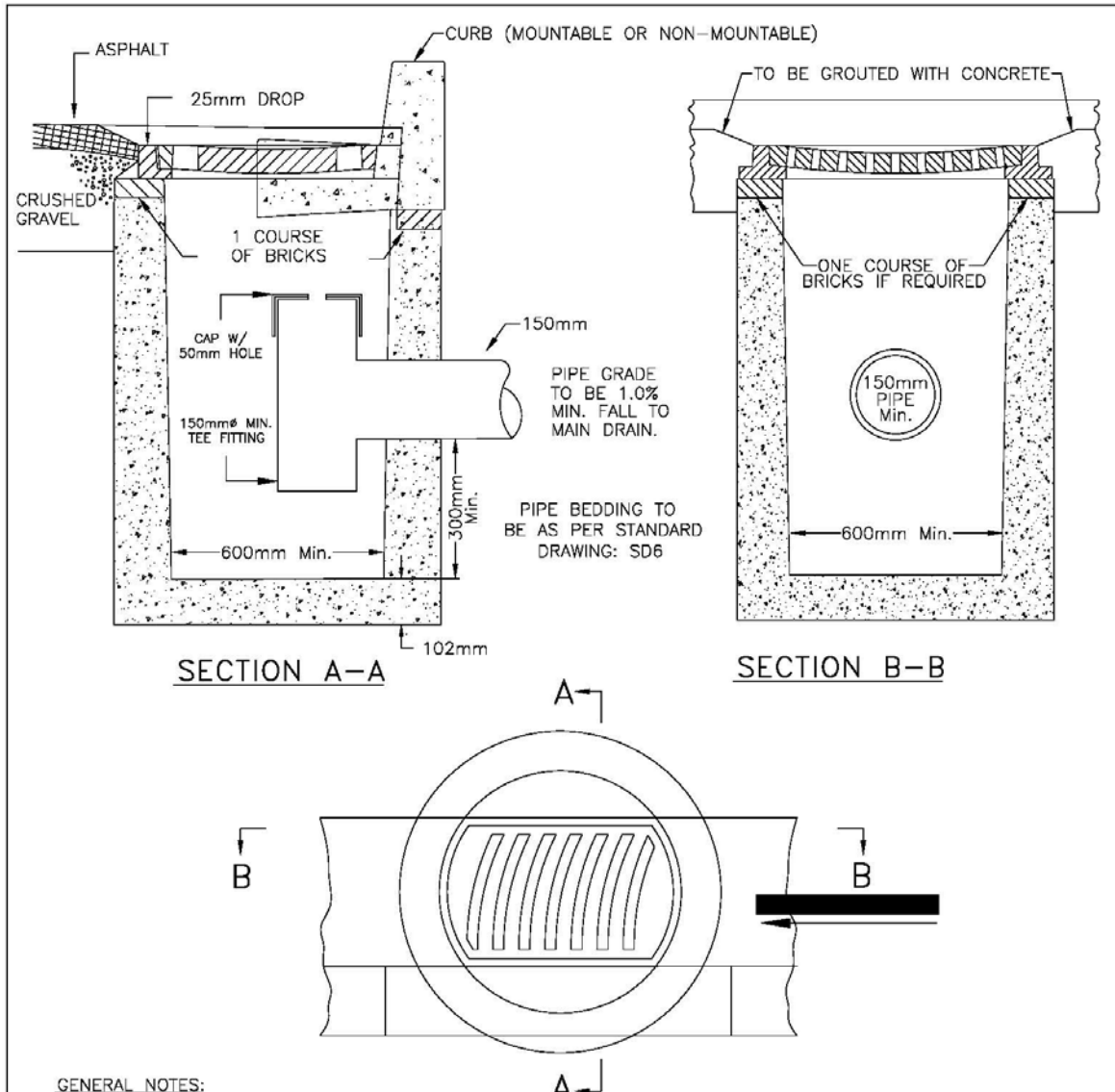

GENERAL NOTES:

1. 3/4 CATCH BASIN GRATE AND FRAME
2. TRENCHES AND CATCH BASINS UNDER TRAVELLED PORTION OF THE ROAD TO BE BACKFILLED WITH GRAVEL AND COMPACTED AS PER SPECIFICATIONS.
3. BASE TO BE COMPACTED GRANULAR MATERIAL (98% STANDARD PROCTOR) OR CONCRETE SLURRY.
4. ALL DIMENSIONS ARE IN MILLIMETERS (mm).

CATCH BASIN

 <p>CITY OF LANGFORD ENGINEERING DEPARTMENT</p>		<p>MMCD SS</p> <p>S11</p>
<p>SCALE: NTS</p>		<p>APPROVED: MM</p>

Last Revised: Bylaw 1669, February 2017

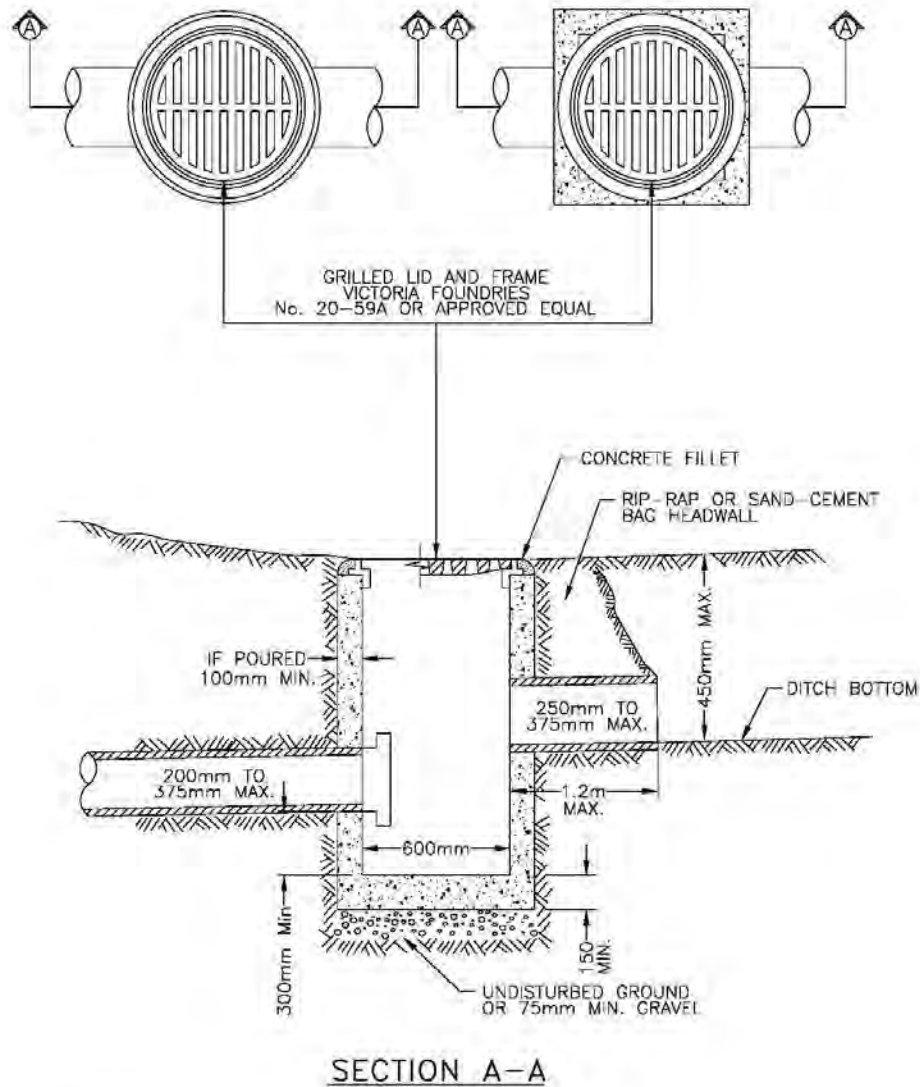

NOTE:

A 1.2m VERTICAL LENGTH OF 600mm CLASS 3 R.C. AS PER CURRENT ASTM C 76 SPECIFICATIONS SET ON END IS ACCEPTABLE IN LIEU OF MIN. 100mm THICKNESS OF POURED CONCRETE AS SHOWN.

DITCH INLET



CITY OF LANGFORD
ENGINEERING DEPARTMENT

DATE:
98/05/06

DRAWN:
GRH

MMCD SS

SCALE:
NTS

APPROVED:

S16

Last Revised: Oct 29, 2009

NOTES:

1. THIS DRAWING SHALL APPLY TO ALL IC INSTALLATIONS WHERE THE IC IS INSTALLED BETWEEN THE GRASSSED BLVD. AND PROPERTY LINE.
2. REFER TO DRAWING MMCD 57 FOR INSTALLATION REQUIREMENTS.
3. INSPECTION CHAMBER TO BE APPROVED MANUFACTURED FITTING.
4. REFER TO CONTRACT DRAWINGS FOR SITE SPECIFIC DIMENSIONS AND MMCD FOR DETAILED SPECIFICATIONS.
5. INSPECTION CHAMBER LID TO BE PERMANENTLY MARKED 'LANGFORD SANITARY' AND MARKED RED.
6. SEE DRAWING 35541 FOR TRENCH DETAIL.

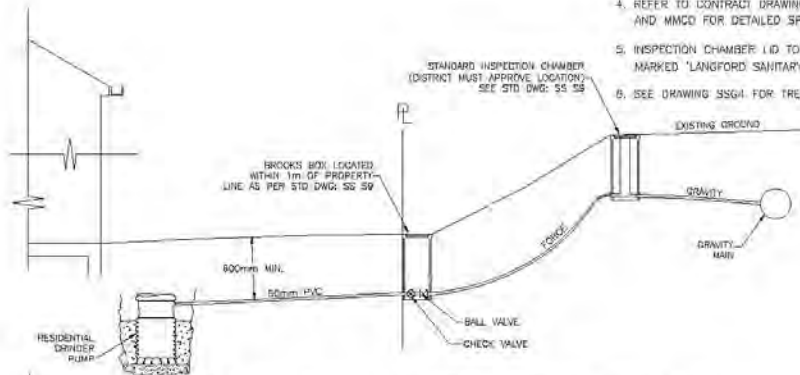

SANITARY FORCE/GRAVITY CONNECTION TO GRAVITY MAIN

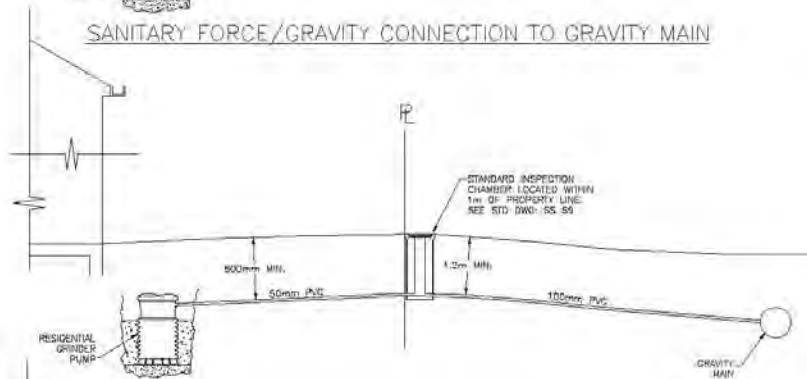

SANITARY FORCE CONNECTION TO GRAVITY MAIN

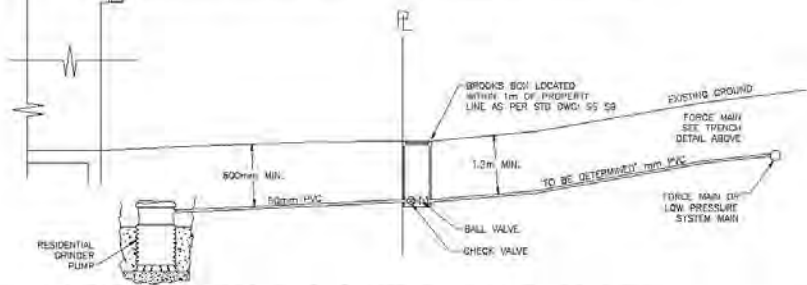

SANITARY FORCE CONNECTION TO LOW PRESSURE SYSTEM MAIN

**SANITARY FORCE
MAIN CONNECTION**



**CITY OF LANGFORD
ENGINEERING DEPARTMENT**

DATE:
99/04/21

DRAWN:
SE

MMCD SS

SCALE:
N.T.S.

APPROVED:

S17

Last Revised: Oct 29, 2009

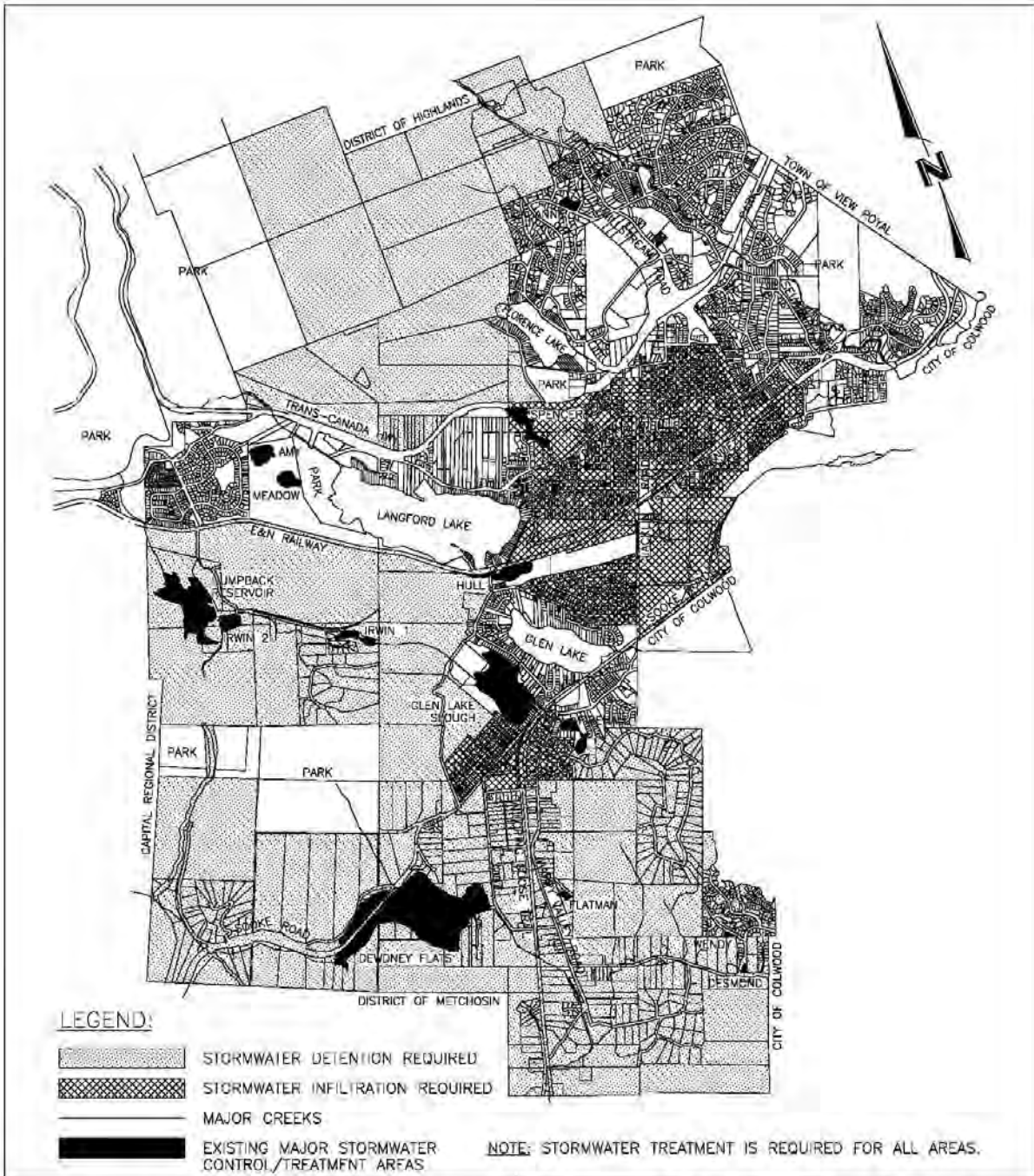

**STORMWATER
CONTROL AND
TREATMENT AREAS**



**CITY OF LANGFORD
ENGINEERING DEPARTMENT**

DATE:
OCT 2002

DRAWN:
MTK

DWG No.

SCALE:
1:40,000

APPROVED:

SD1

Last Revised: Oct. 23, 2009

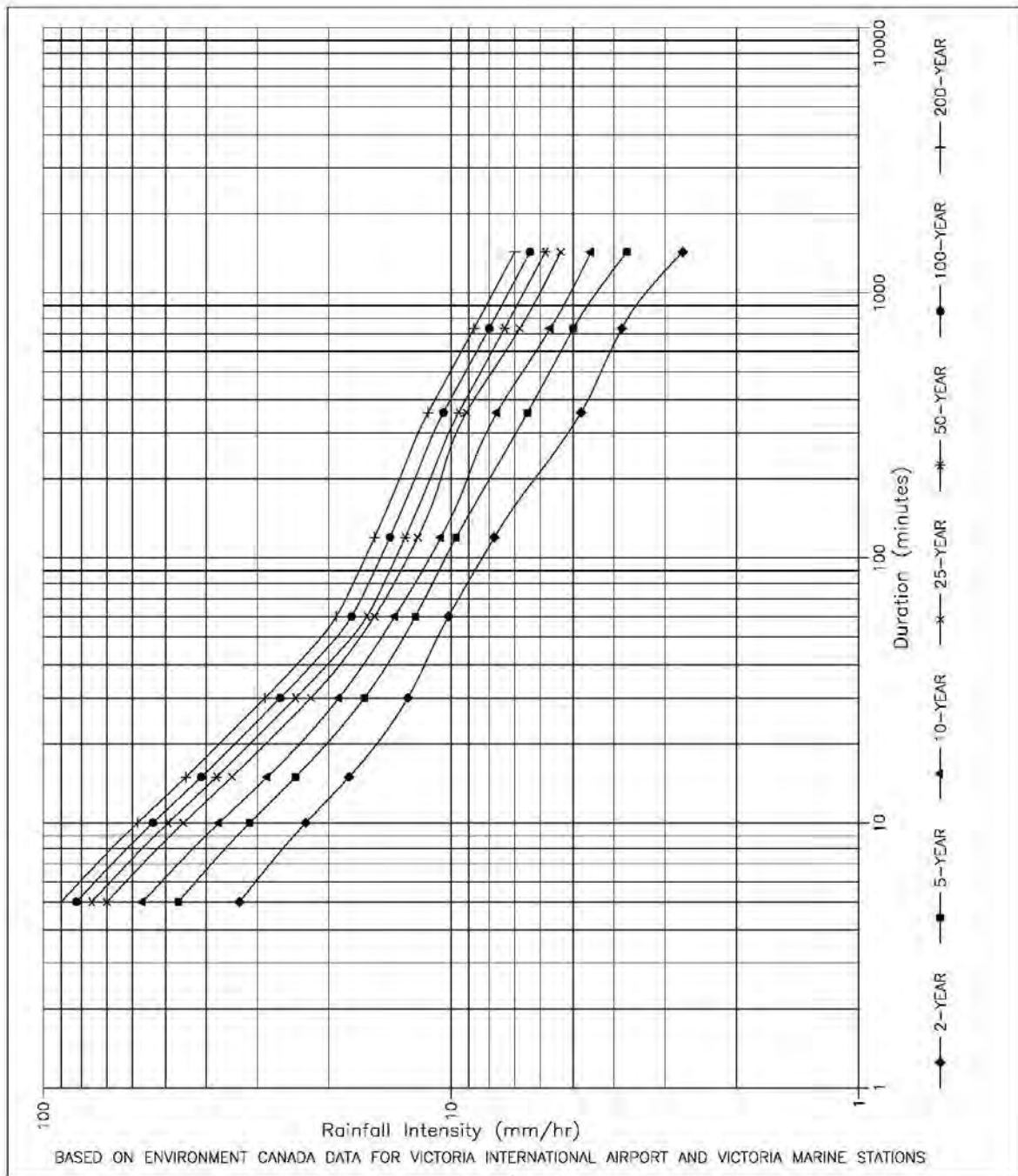

**LANGFORD RAINFALL
INTENSITY-DURATION
FREQUENCY CURVE**



**CITY OF LANGFORD
ENGINEERING DEPARTMENT**

DATE:
OCT 2002

DRAWN:
MTK

SCALE:
NTS

APPROVED:

SD-3

Last Revised: Oct 23, 2009

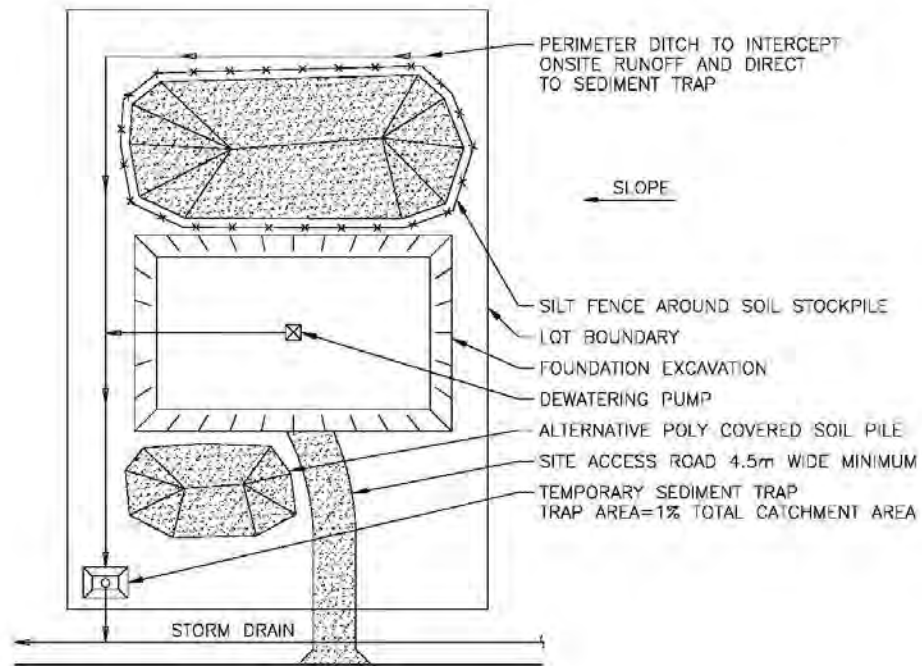

LOT PLAN

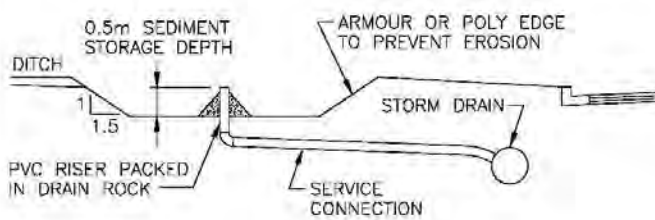

TEMPORARY SEDIMENT TRAP SECTION DETAIL

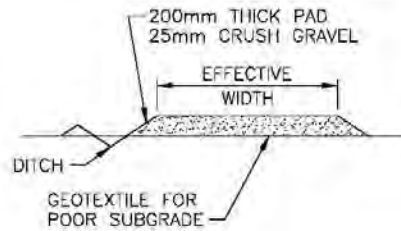

ACCESS ROAD SECTION DETAIL

SOURCE: LAND DEVELOPMENT GUIDELINES FOR THE PROTECTION OF AQUATIC HABITAT.

**LOT DEVELOPMENT
EROSION AND
SEDIMENT CONTROL**



**CITY OF LANGFORD
ENGINEERING DEPARTMENT**

DATE:
OCT 2002

DRAWN:
MTK

SCALE:
NTS

APPROVED:

SD-4

Last Revised: Oct 23, 2009

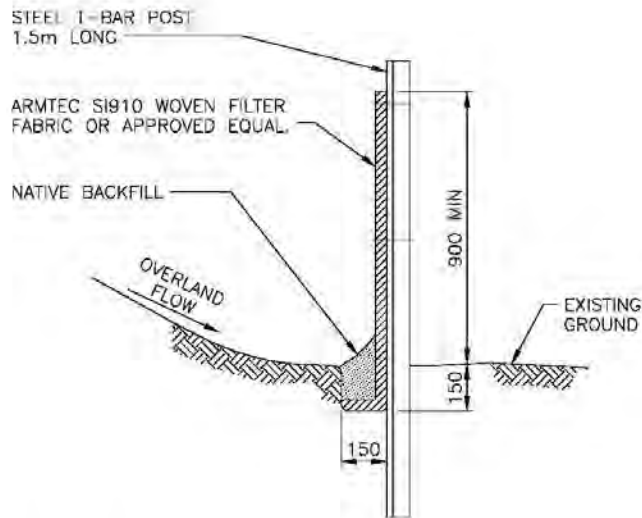

NOTES:

1. WOVEN FILTER FABRIC TO BE SECURED TO T-BAR AT TOP AND MIDPOINT WITH NYLON ZIP TIES.
2. FABRIC ROLL TO ROLL CONNECTIONS TO BE AS PER MANUFACTURER'S SPECIFICATIONS.
3. TOP TENSION WIRE TO BE 3mm GALVANIZED WIRE SECURED TO POSTS. FABRIC TO BE SECURED TO TENSION WIRE AT MIDPOINT.
4. T-BAR POSTS TO BE SPACED NOT MORE THAN 2.4m APART, CENTER TO CENTER.

SILT FENCE



**CITY OF LANGFORD
ENGINEERING DEPARTMENT**

DATE:
OCT 2002

DRAWN:
MTK

SCALE:
NTS

APPROVED:

SD-5

Last Revised: Oct 23, 2009

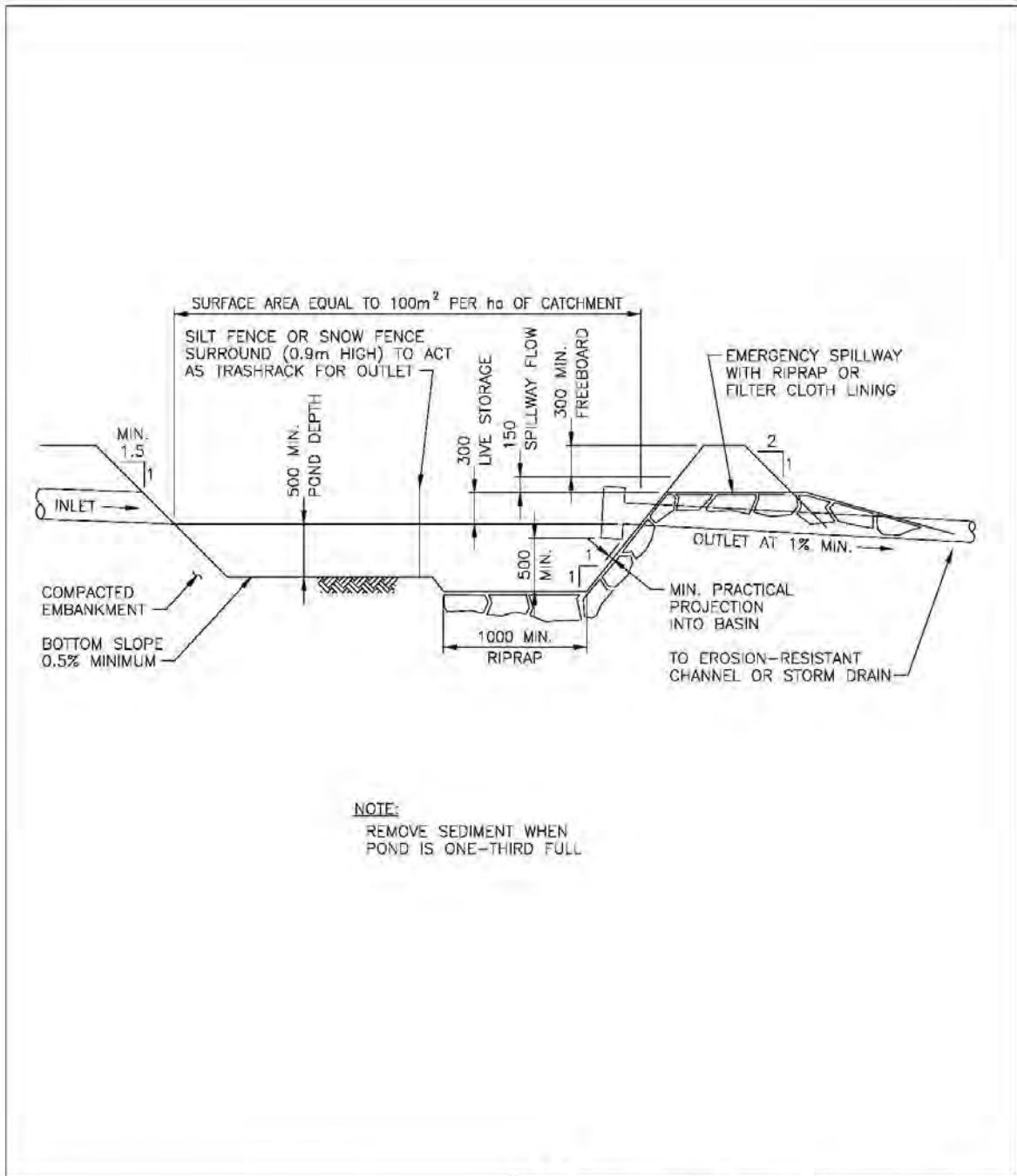

NOTE:
REMOVE SEDIMENT WHEN
POND IS ONE-THIRD FULL

SEDIMENT BASIN



CITY OF LANGFORD
ENGINEERING DEPARTMENT

DATE:
OCT 2002

DRAWN:
MTK

SCALE:
NTS

APPROVED:

SD-6

Last Revised: Oct 23, 2009

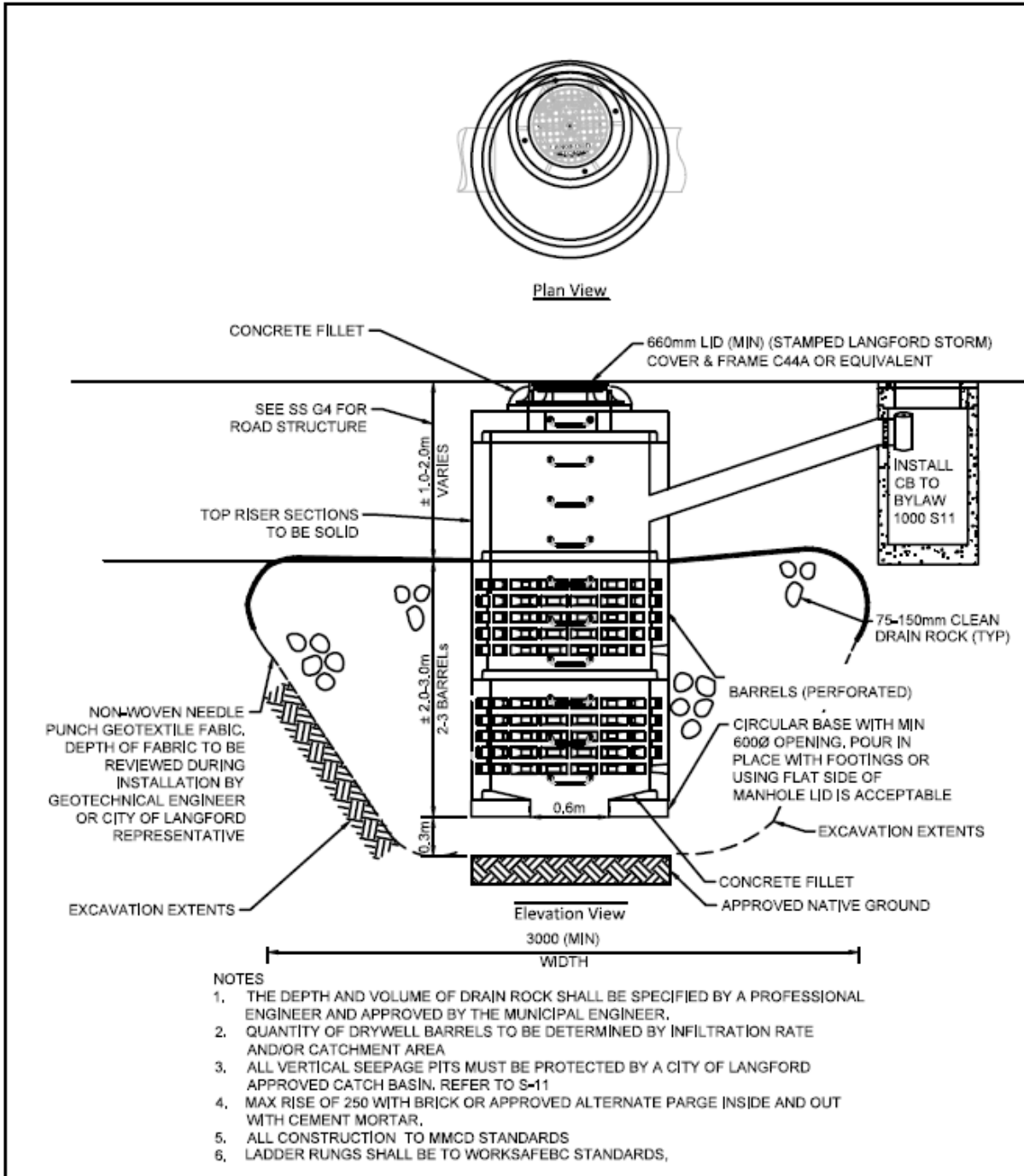

VERTICAL SEEPAGE PIT DETAIL	 CITY OF LANGFORD ENGINEERING DEPARTMENT		SD -7
	DATE: APRIL 30, 2020	DRAWN: DRH	
	SCALE: NTS	APPROVED: GH	

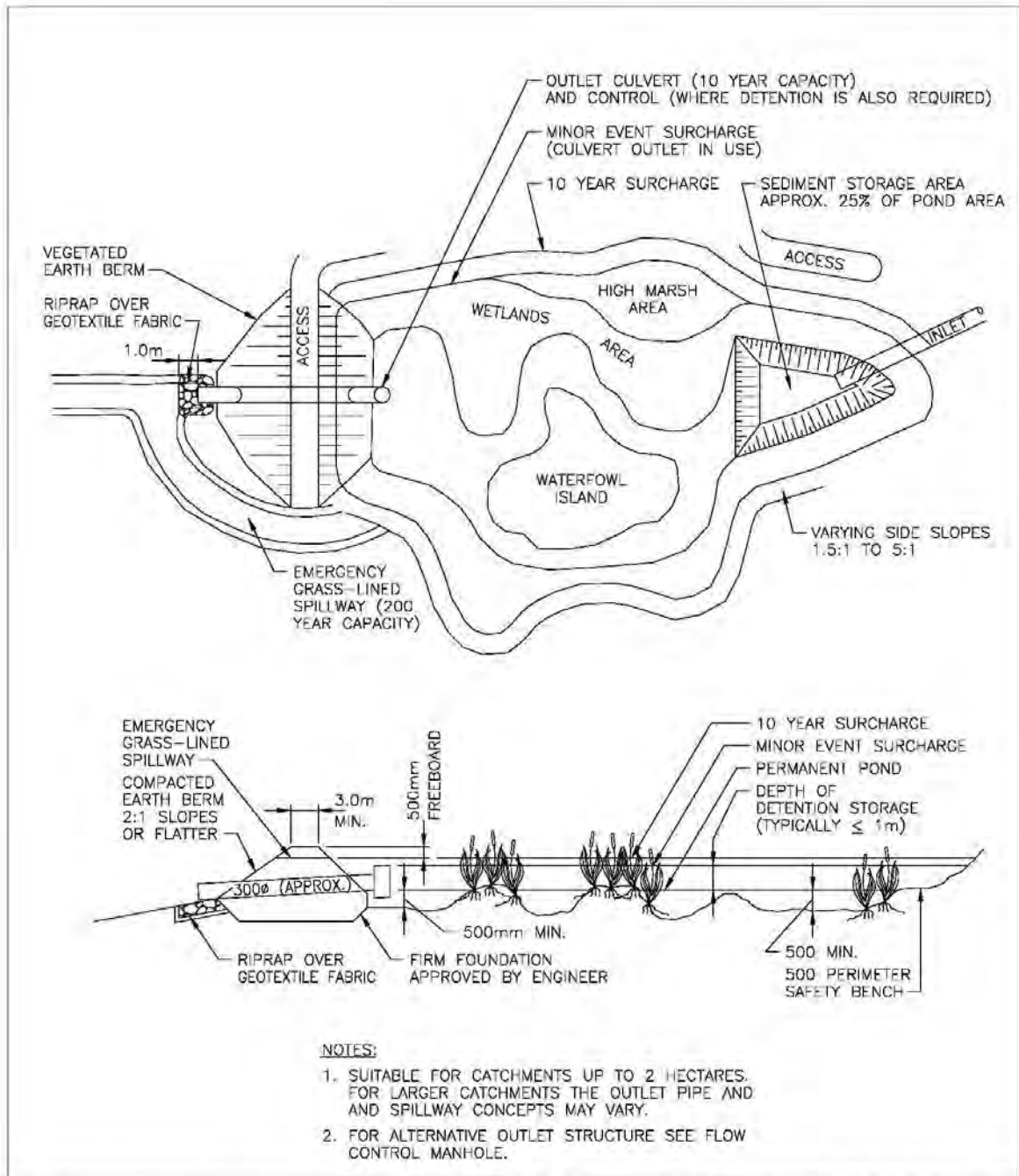

**COMBINED CONSTRUCTED
WETLAND AND
DETENTION FACILITY**



**CITY OF LANGFORD
ENGINEERING DEPARTMENT**

DATE:
OCT 2002

DRAWN:
MTK

SCALE:
NTS

APPROVED:

SD-8

Last Revised: Oct 23, 2009

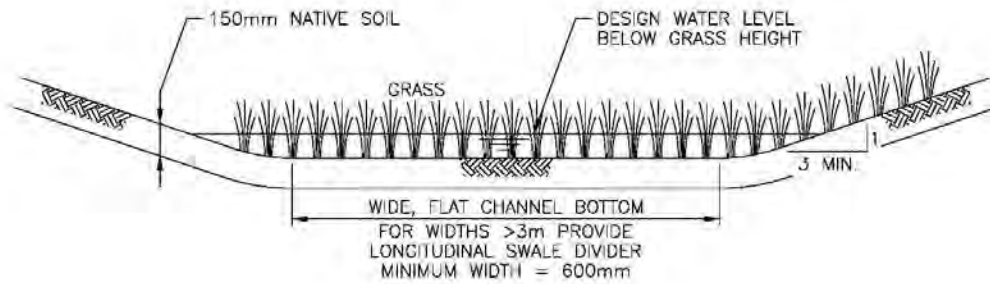

NOTES:

1. GRASS MUST STAND UP TO FLOW AND NOT BE PRESSED FLAT BY FLOW. MAXIMUM FLOW DEPTH = 100mm OR 50mm FOR FREQUENTLY MOWED AREAS.
2. CHANNEL BASE AREA IS A FUNCTION OF CATCHMENT AREA. CHANNEL AREA (WIDTH x LENGTH) = 1% OF CATCHMENT AREA. MINIMUM LENGTH = 30m.
3. USE FLOW SPREADER AT INLET TO ENSURE ENTIRE WIDTH OF SWALE IS WETTED.
4. LONGITUDINAL SLOPE = 1% TO 6%
5. ON GRADES GREATER THAN 6%, GEOTECHNICAL ENGINEERING CERTIFICATION SHALL BE REQUIRED TO ENSURE SLOPE STABILITY.

GRASS SWALE



**CITY OF LANGFORD
ENGINEERING DEPARTMENT**

DATE:
OCT 2002

DRAWN:
MTK

SCALE:
NTS

APPROVED:

SD-9

Last Revised: Oct 23, 2009

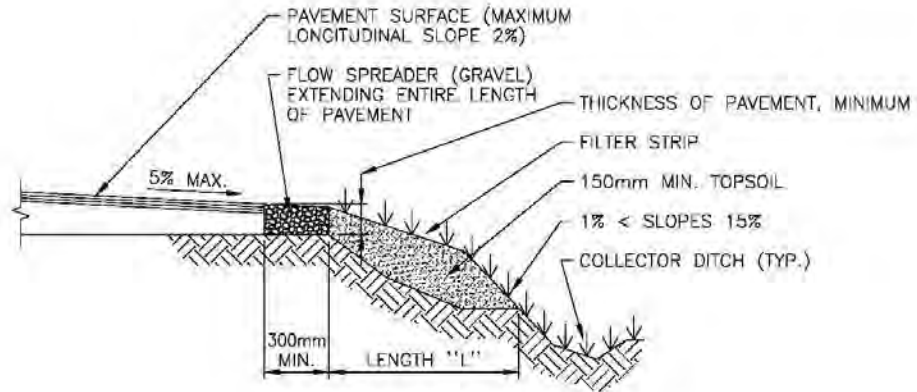

NOTE: THE BASIC FILTER STRIP IS TYPICALLY ADJACENT AND PARALLEL TO A PAVED AREA SUCH AS PARKING LOTS, DRIVEWAYS AND ROADWAYS.

FILTER STRIP



CITY OF LANGFORD
ENGINEERING DEPARTMENT

DATE:
OCT 2002

DRAWN:
MTK

SCALE:
NTS

APPROVED:

SD-10

Last Revised: Oct. 23, 2009

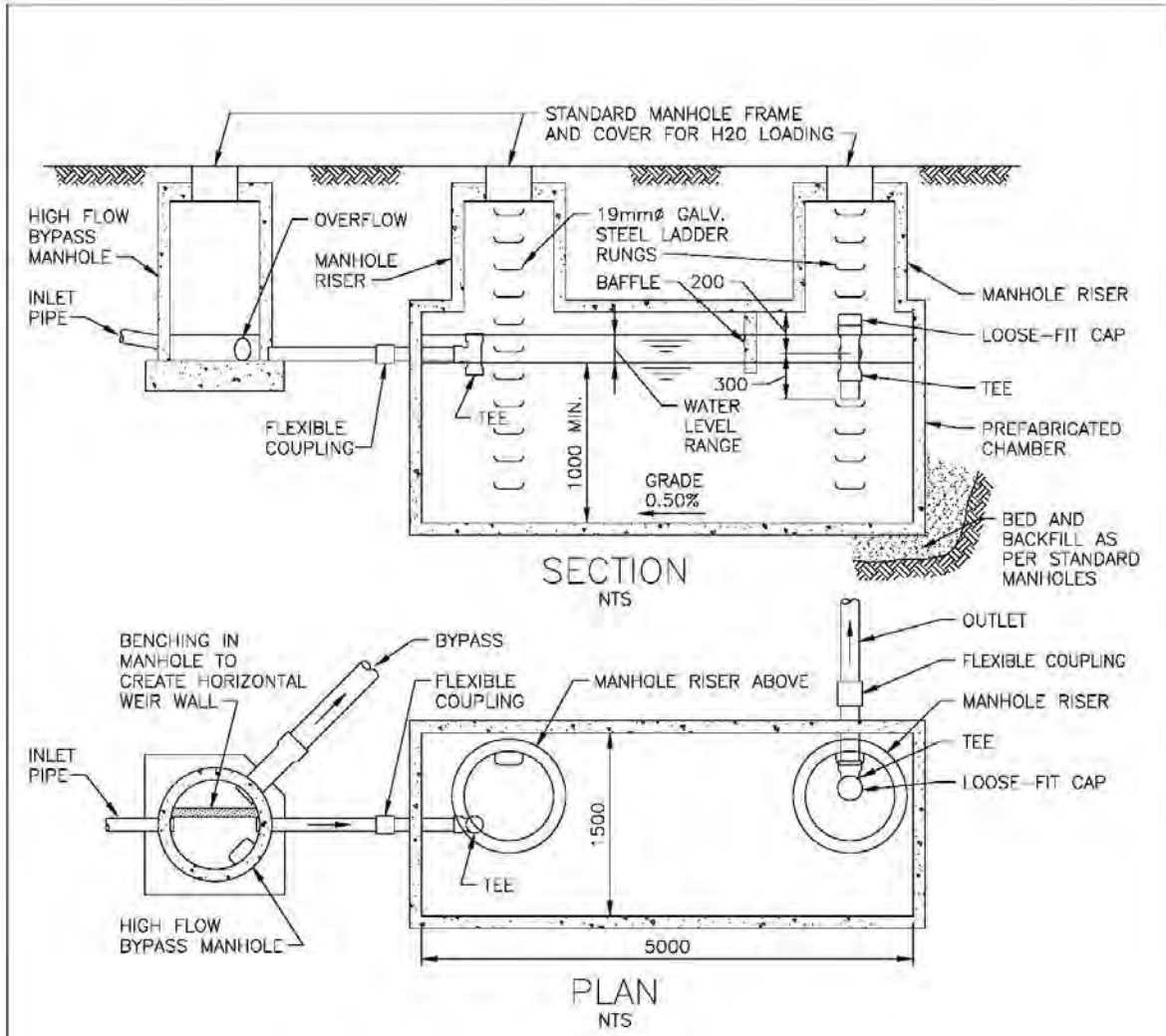

NOTES:

1. SIZE CHAMBER FOR 0.25m² OF WATER SURFACE AREA PER 1 L/s OF 6-MONTH DESIGN FLOW. HIGHER FLOWS TO BE BYPASSED.
2. ILLUSTRATED CHAMBER SUITABLE FOR 6-MONTH DESIGN FLOW OF 30 L/s.
3. HIGH FLOW BYPASS NOT REQUIRED IF WATER SURFACE AREA IN CHAMBER EXCEEDS 0.70m² PER 1 L/s (10 YEAR).

**OIL/GRIT SEPARATOR
CHAMBER WITH EXTERNAL
HIGH FLOW BYPASS**



**CITY OF LANGFORD
ENGINEERING DEPARTMENT**

DATE:
OCT 2002

DRAWN:
MTK

SCALE:
NTS

APPROVED:

SD-11

Last Revised: Oct 23, 2009

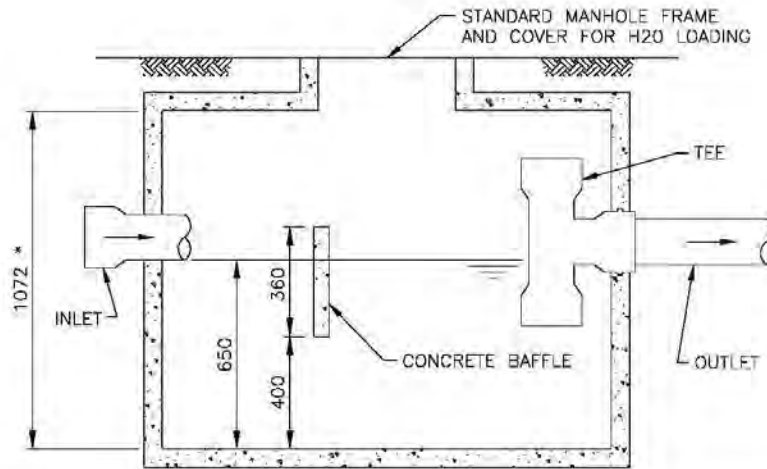

SECTION
NTS

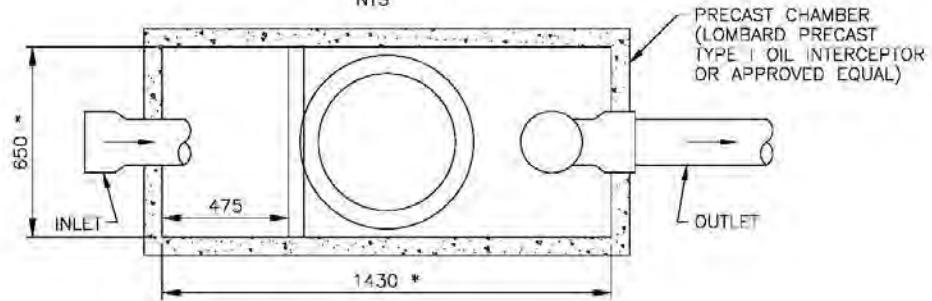

PLAN
NTS

* INSIDE DIMENSIONS

NOTES:

1. USE FOR PAVEMENT AREAS UP TO 1000m² WITH HIGH FLOW BYPASS. BYPASS ALL FLOW GREATER THAN 4 L/s.
2. USE FOR PAVEMENT AREAS UP TO 380m² WITHOUT A HIGH FLOW BYPASS.
3. CORE CHAMBER AS REQUIRED FOR OPTIONAL INLET AND OUTLET LOCATIONS. CORE LOCATIONS TO BE BETWEEN THE CHAMBER INLET WALL AND BAFFLE.

**OIL/GRIT
SEPARATOR
TYPE 1**



**CITY OF LANGFORD
ENGINEERING DEPARTMENT**

DATE:
OCT 2002

DRAWN:
MTK

SCALE:
NTS

APPROVED:

SD-12

Last Revised: Oct 23, 2009

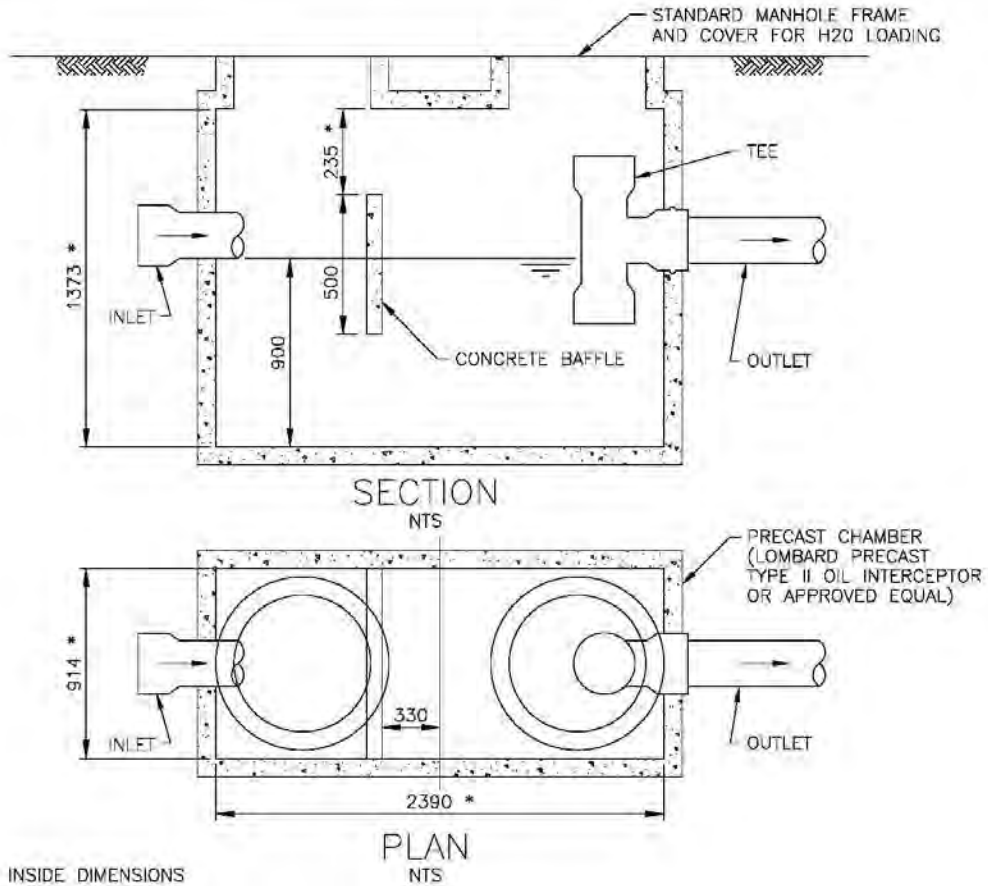

* INSIDE DIMENSIONS

NOTES:

1. USE FOR PAVEMENT AREAS UP TO 2400m² WITH HIGH FLOW BYPASS. BYPASS ALL FLOW GREATER THAN 9 L/s.
2. USE FOR PAVEMENT AREAS UP TO 900m² WITHOUT A HIGH FLOW BYPASS.
3. CORE CHAMBER AS REQUIRED FOR OPTIONAL INLET AND OUTLET LOCATIONS. CORE LOCATIONS TO BE BETWEEN THE CHAMBER INLET WALL AND BAFFLE.

**OIL/GRIT
SEPARATOR
TYPE 2**



**CITY OF LANGFORD
ENGINEERING DEPARTMENT**

DATE:
OCT 2002

DRAWN:
MTK

SCALE:
NTS

APPROVED:

SD-13

Last Revised: Oct 23, 2009

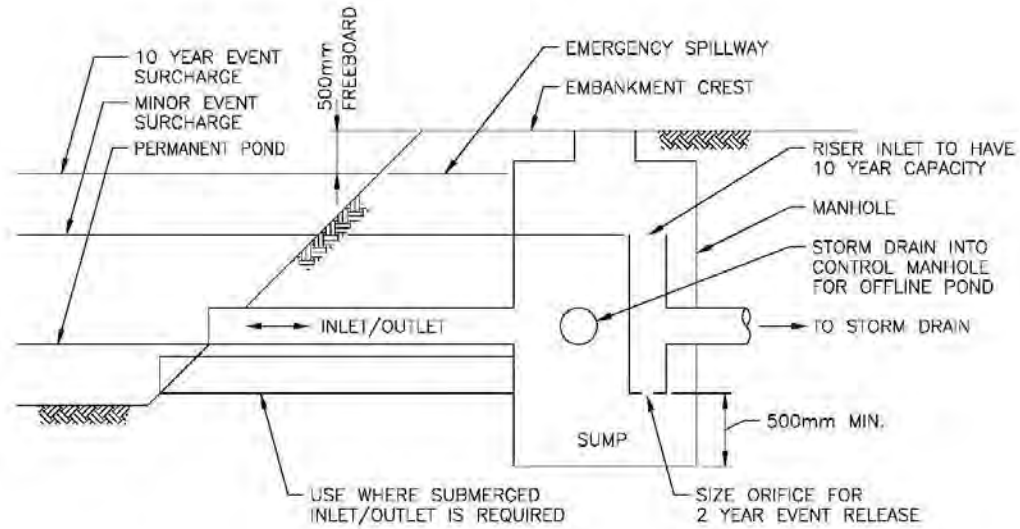

NOTES:

1. TO BE USED WITH STANDARD DETENTION POND WHERE OUTLET IS TO STORM DRAIN SYSTEM OR WHERE SECURITY OF CONTROL STRUCTURE IS REQUIRED.
2. THIS DESIGN FOR 2 YEAR PEAK FLOW CONTROL ONLY.

**FLOW
CONTROL
MANHOLE**



**CITY OF LANGFORD
ENGINEERING DEPARTMENT**

DATE:
OCT 2002

DRAWN:
MTK

SCALE:
NTS

APPROVED:

SD-14

Last Revised: Oct 23, 2009

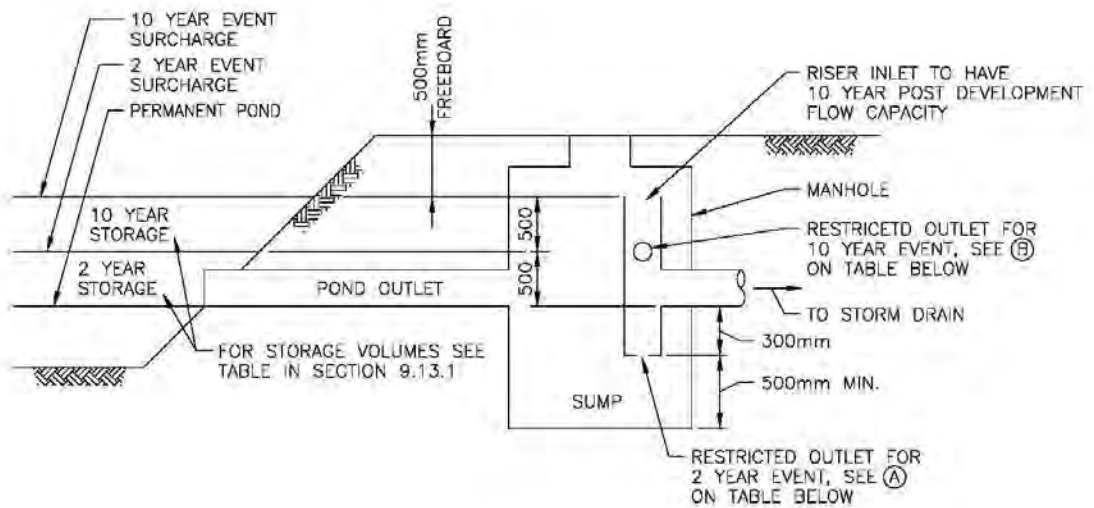

SOIL TYPE	1.0 HA CATCHMENT		0.5 HA CATCHMENT	
	(A) (mm ϕ)	(B) (mm ϕ)	(A) (mm ϕ)	(B) (mm ϕ)
ROCKY SITE	80	70	60	40
SILTS/CLAYS	75	50	50	40
SANDS/GRAVELS	60	40	40	35

**STORAGE
AND
OUTLET SIZING**



**CITY OF LANGFORD
ENGINEERING DEPARTMENT**

DATE:
OCT 2002

SCALE:
NTS



DRAWN:
MTK

APPROVED:

SD-16

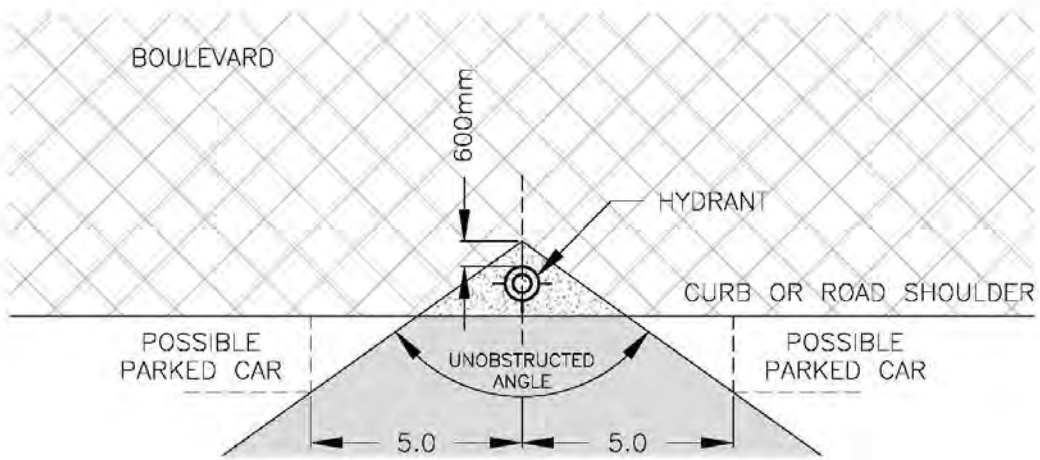
Last Revised: Oct 23, 2009



-  **SHRUB AND TREE ZONE**
-BRANCHES NOT TO PROTRUDE INTO CRITICAL HYDRANT TRIANGLE
-  **NO SHRUB ZONE**
-GROUND COVER, PERENNIALS AND ANNUALS ONLY - UP TO 150mm HEIGHT NEXT TO HYDRANT
-  **CLEARANCE ZONE**
-FOR HYDRANT SAFETY LINES

NOTES:
 1. ALL DISTANCES IN METERS
 2. NO RED BLOOMING PLANTS NEAR HYDRANT FOR VISIBILITY

<h2>Fire Hydrant Clearance Specifications</h2>	 CITY OF LANGFORD ENGINEERING DEPARTMENT		
	DATE: 24-Mar-14	DRAWN: TWB	DWG No.
	SCALE: NTS	APPROVED:	W1

Last Revised: March 27, 2014

SCHEDULE 12 – DRAFTING STANDARDS

12.

12.1. General Procedures

12.1.1. Introduction

The City of Langford's Contract Drawing and Drafting Standards are to be applied to all drawing submissions made to the City. These standards are necessary to ensure that the City receives consistent drawings compatible with the City's corporate GIS system.

The City of Langford's Contract Drawing and Drafting Standards are based on current versions of the industry standard software by Autodesk and ESRI. AutoCad Map 3D and ESRI ArcGIS are the preferred drafting, design and GIS programs to be utilized by all contractors to the City. The only file formats that the City of Langford will accept are AutoCad .dwg files or ESRI .shp file sets.

12.1.2. General

- 12.1.2.1. All submitted digital drawings must reference the UTM Nad83 coordinate system. All X-Ref drawings must be included with submissions, preferably incorporated into the drawing itself.

All drawings submitted using Autodesk software must be designed in Model Space and plotted using Layouts. Each drawing layout is to include and is limited to one drawing sheet.

The drawing sheets will include single or multiple view ports depending on the amount of design detail required to be shown. Each view port will include a scale that best reflects the amount of detail required to be shown in the view port. The User Coordinate System (UCS) can be rotated to allow better viewing of the design works, but a north arrow must always be shown and the amount of rotation must be recorded in the title block.

All drawings submitted will comply with the City of Langford's Detailed Mapping Specifications available from the City's website or the City's GIS staff.

12.1.3. Drawing Review

- 12.1.3.1. All street names and street types shown on submitted drawings must be spelled and represented correctly. This information is available from the current street map on the City's website.

12.1.4. Minimum Standards

- 12.1.4.1. Submission package is complete.
- 12.1.4.2. NAD83 Coordinate system.
- 12.1.4.3. All works must be tied to current City of Langford parcel data.
- 12.1.4.4. All new parcels must be tied to a minimum of two control monuments.
- 12.1.4.5. Data structure to adhere to the City's Detailed Mapping Specifications.
- 12.1.4.6. Xref files to be included if applicable.
- 12.1.4.7. Must be .dwg or .shp file series format.
- 12.1.4.8. Drawing must note scaling factor, north arrow and rotation angle if UCS is applied.
- 12.1.4.9. Correct street names displayed.

12.1.5. Submission Package

- 12.1.5.1. Drawing Submission packages must be complete and clearly labelled and include the City's file reference. Final packages will include 1 sealed colour hard copy drawing at an appropriate scale for quality review as well as a colour .pdf representation of the hard copy drawing. To accompany the hard copy drawings and .pdf file is the digital file used to compile the hard copy drawings in either .dwg or .shp.

12.2. Langford Reference Data

12.2.1. Introduction

The City of Langford's cadastral fabric is updated on a regular basis with new plans and additional control points to ensure the most accurate parcel information is available.

12.2.2. Additional Files Provided

Prior to preparing drawing submissions for the City, contractors must obtain the current relative data sets from the City's website or from the City's GIS staff. The files listed below will be available on the City's website and must be referenced in all new drawings submitted.

- 12.2.2.1. City of Langford Cadastral
- 12.2.2.2. City of Langford contours

- 12.2.2.3. City of Langford Street Map (reference)
- 12.2.2.4. City of Langford Address Map (reference)
- 12.2.2.5. City of Langford Control Monuments
- 12.2.2.6. City of Langford Title Block
- 12.2.2.7. City of Langford Detailed Mapping Specifications
- 12.2.2.8. Standard AutoCad blocks
- 12.2.2.9. Langford.ctb
- 12.2.2.10. Images and other support files may be requested from the GIS department as required.

Note: The City of Langford cadastral will be provided to the contractor as reference in the area of works. Although the cadastral information will be available, any property lines, iron pins, or control monuments adjacent to the works, within the limit of construction must be surveyed.

- 12.2.3. All contractors will be required to download the most current / appropriate Title Block from the City's Website. The drawing contractor is to fill out and update the attributes upon each submission of drawings.

SCHEDULE 13 PARKS AND TRAIL CONSTRUCTION

13.1 Trail Construction.

The purpose of these standards is to establish a set of trail types and design guidelines for new trail construction and trail upgrading within the City of Langford. (Bylaw 1817)

13.1.1 Any unique trail situations other than those presented below are to be approved by the Parks Manager. (Bylaw 1817)

13.1.2 Construction of stairs and railings shall meet the BC Building Code requirements.

13.1.3 Trail signage is required for all trails. Requirements for trail signage will be determined by the Parks Manager and may include, but are not limited to:

13.1.3.1 Design Standard for the Langford Trail Marker;

13.1.3.2 The standard for signage that identifies those parks and trails developed and maintained by the City of Langford;

13.1.3.3 Trail Signage Standards – Approved Symbols for Facilities (from Park Facility Standards, BC Parks 1993);

13.1.3.4 Trail Signage Standards – Approved Symbols for Pedestrian and Bicycle Traffic (from Uniform Traffic Control Devices for Canada, Roads and Transportation Association of Canada) N.B. Pedestrian and Bicycle traffic signs should be reduced by one-half or one-third the size normally required for vehicular traffic. See the UTCDC manual for vehicular standard.

13.1.4 Bollards shall be constructed per drawing T1.

Table 13-1: Design Criteria and Standards for Trail Width and Surfacing

Trail Type	Design Criteria	Tread Width	Surface
Hiking Trail	Pedestrian/hiking only; single file	Min: 0.45m Max: 0.6m	Gravel
Nature Trail	Natural Areas/Corridors of minor creeks; low level use; multiple simultaneous users (eg. walking, jogging, hiking, mountain biking - pedestrians and cyclists); trail infrastructure (occasional benches, viewpoints, bollards, stairs, occasional waste/recycling receptacles, signs -directional, instructional, interpretive)	Min. 0.3m Max. 1.0m; complete with 0.5m min. on each side of trail (unobstructed clear width) and 2.4m clear height Preferred widths to be provided where there are no constraints.	Compacted native soil and aggregate or mulch where needed. Base to be native material.

Pedestrian Walkways and Trails	Generally for short urban connectors; primarily for pedestrian use	1.8 m	Gravel, except beside side yards – surfacing to be concrete
Multi-Use Trail	Longer connector trails; multiple simultaneous users (pedestrians and cyclists)	Min. 3m Max: 4m	Asphalt

(Bylaw 1817)

Table 13-2: Trail Gradient Standards

Trail Type	Optimum Grade	Maximum Sustained Grade	Maximum Short Distance Grade – Length not greater than 6m
Hiking Trail	0-5%	10%	20-25%
Nature Trails	0-10%	20%	20-25%
Pedestrian Walkways and Trails	0-3%	5%	15%
Multi-Use Trail	0-3%	5%	12%

Table 13-3: Trail Construction Standards

Tread Type	Sub Grade	Tread
Hogfuel	Not recommended	To be determined by Parks Manager on a case by case basis
Gravel	75-150mm thickness of pit run gravel compacted; where required place 75mm clear rock for drainage in low areas	75mm of 6mm thickness minus crushed gravel
Native Soil	Native material	Compacted native material
Asphalt	100mm thickness of pit run. Gravel compacted	50mm thickness of hot mix asphalt
Concrete	Please refer to MMCD Specifications for concrete thickness and strength.	

13.2 Irrigation

Irrigation shall be undertaken in accordance with specifications and locations set forth in Schedule 10.

13.3 Parks and Trails Trees

All trees planted within Parks and Trails complete with municipal irrigation shall be installed in accordance with the specifications set forth in Schedule 10, Schedule 14 and Schedule 11, details L1(a), L1(b), L2(a), L2(b), L2(c), L2(d), L2(e), L3(a), and L3(b) as applicable.

Langford Trail Marker

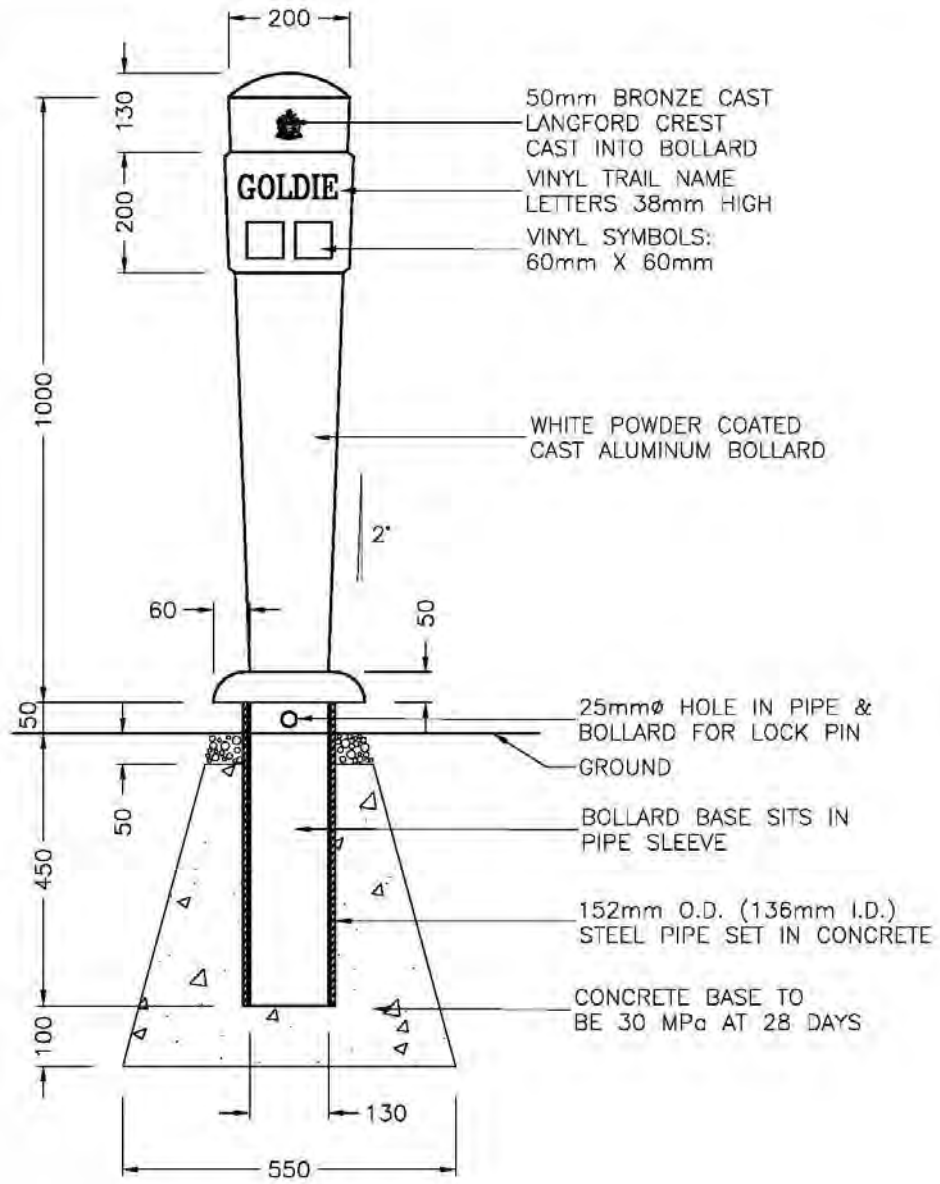

NOTE:
 REFER TO APPROVED PRODUCT LIST FOR
 BOLLARD AND IN GROUND SLEEVE SPECIFICATION

Dog Home: Langford Trail Marker

LANGFORD TRAIL MARKER



CITY OF LANGFORD
 ENGINEERING DEPARTMENT

DATE: 99/05/14
 SCALE: 1:10

DRAWN: GRH
 APPROVED: MM
MMCD SS
T1

Last Revised: Bylaw 1817, February 2019

SCHEDULE 14

BOULEVARD LANDSCAPE STANDARDS

14.1. Submission Approval Requirements

14.1.1. Landscape plans, Irrigation plans and detailed landscape cost estimates must be submitted to Parks and approved prior to commencing landscape work on any park, boulevard or public land within the development boundary. (Bylaw 1817)

14.1.2. Landscape plans must be drawn and approved by the landscape professional of record as follows:

14.1.2.1. A Landscape Architect is required for Developments (including offsite works) within the City Centre, Sooke Road Commercial Revitalization, Business Park, Industrial, Commercial, or Multi-Family Residential Development Permit Areas identified in the Official Community Plan.

14.1.2.2. A Landscape Architect or other qualified person as approved by the Director of Parks, Recreation and Facilities is required for:

Off-site landscape works on internal roadways and boulevards where the subdivision creates more than 3 new lots; and

Boulevard areas on existing roadways for developments and/or Subdivisions which create more than 3 new lots.

14.1.3. Landscape plans should be drawn by or coordinated by a Civil Engineer who has been engaged to provide Landscape details and supervise the works on install for:

14.1.3.1. Subdivisions less than 3 lots or

14.1.3.2. Boulevard areas on existing roadways for subdivisions which create less than 3 new lots.

14.1.4. Irrigation plans must be designed by a certified irrigation designer – turf/commercial classification as certified by IIABC or IA. (Bylaw 1817)

14.1.5. The developer must submit a detailed landscape cost estimate for the supply and installation of frontage (off-site) landscape works prepared by a Landscape Architect or other qualified professional approved by the Director of Parks, Recreation, and Facilities. Cost estimates should include supply and installation, and are not limited to:

14.1.5.1. Site Preparation and Grading

14.1.5.2. Topsoil/Growing medium (Bylaw 1817)

14.1.5.3. Plant Material (Bylaw 1817)

- 14.1.5.4. Irrigation
 - 14.1.5.5. Mulch (Bylaw 1817)
 - 14.1.5.6. Artificial Turf (Bylaw No. 1669)
 - 14.1.5.7. Sod/Hydroseeding (Bylaw 1817)
 - 14.1.5.8. Granular trails, and any other hard surfaces (Bylaw 1817)
 - 14.1.5.9. Fencing (eg. Chain link fence, split rail fence, etc.) (Bylaw 1817)
 - 14.1.5.10. Site furniture (eg. Trail bollards, lighting bollards, benches, wastereceptacles, bike racks, etc.) (Bylaw 1817)
 - 14.1.5.11. Stairs and bridges and boardwalks (Bylaw 1817)
 - 14.1.5.12. Record landscape drawings and Record irrigation drawings for both production and submission (Bylaw 1817)
 - 14.1.5.13. Deleted (Bylaw 1817)
 - 14.1.5.14. Deleted (Bylaw 1817)
- 14.1.6. Ensure all minimum utility offsets, driveway offsets and sightlines are met and therefore all boulevard tree locations show on the drawing are confirmed viable. If there is inadequate space within the road right of way, the Director of Engineering and Parks Manager may require a 2 metre wide statutory right of way on either side of the dedicated road for the purposes of planting and maintaining trees, irrigation and ancillary fittings. (Bylaw Nos. 1669, 1817)
- 14.1.6.1. Minimum tree planting setbacks measured from the centre of the tree trunk, from above and below grade utilities and property lines are as follows:

Light Standards	3.5m (137.8")
BC Hydro Kiosks and Vaults	3.5m (137.8")
BC Hydro Underground Lines	1.5m (59.1")
Fire Hydrants	3.5m (137.8")
Stop Signs	*3.5m (137.8")
Water Main/ Water services	1.8m (70.8")
Catch Basins/Valve Boxes	1.5m (59.1")
Utility Box Lids	2.0m (78.7")
Gas Services	1.0m (39.3")
Sanitary & Storm Sewer Service	1.8m (70.8")
Sanitary & Storm Sewer Mains & Manholes	2.0m (78.7")
Curb or Sidewalk	*1.0m (39.3")

Driveways/Crossings	*2.5m (98.4")
*Ensure trees do not create sightline obstructions for vehicles.	

14.1.7. Deleted by Bylaw No. 2103.

14.1.8. Deleted by Bylaw No. 2103.

14.1.9. Landscape plans, civil drawings and Irrigation plans submitted for approval must include the following information: (Bylaw 1817)

14.1.9.1. Subdivision name and file number; (Bylaw 1817)

14.1.9.2. Key Plan, north arrow, date, scale and bar scale; (Bylaw 1817)

14.1.9.3. Proposed property lines and right-of-ways; (Bylaw 1817)

14.1.9.4. All Streets, road and walkway alignments; (Bylaw 1817)

14.1.9.5. All existing and proposed above and below grade utility services, alignments and fixtures, such as utility pedestals, fixtures, art installations, monuments, statues, street lights, walkway lights, signage, amenities, catch basins, manholes, high, intermediate and low pressure lines, overhead power lines, sewers, sanitary, water lines, gas lines, etc.; (Bylaw 1817)

14.1.9.6. The surveyed location and size of all existing trees of 15cm caliper within the municipal right-of-way; (Bylaw 1817)

14.1.9.7. All proposed landscaping including but not limited, to boulevard trees, shrubs, shrub beds, sodded or seeded turf grass areas, playgrounds, walkways, artificial turf, etc (Bylaw 1817)

14.1.9.8. Plant List including plant material botanical and common names, cultivar / variety, minimum caliper or height, root treatment (eg. Balled and Burlaped, wire basket specification, tree spade or potted), total quantities of each plant and remarks including special comments or unique installation criteria; (Bylaw 1817)

14.1.9.9. Irrigation design drawing to reflect either extending existing municipal irrigation from the adjacent development or a new CRD dedicated City water meter connection for the development offsite landscaping. (Bylaw 1817)

14.1.9.10. CRD dedicated water meter connection, dedicated live line power, double check valve assembly, controller, valves, mainlines, lateral lines, Irrigation Schedule, Valve Schedule, Critical Analysis and Reference Notes Schedule are required as a minimum, to be included on the irrigation drawings. Refer to Schedule 10 for further irrigation design and record drawing submission requirements. The dedicated water meter connection and live line power for the irrigation system

must be included on the Civil Engineer's drawing of water supply services.
(Bylaw 1817)

14.2. Boulevards and Medians (Bylaw 1817)

14.2.1. Plant materials to be nursery grown stock and comply with British Columbia standard for container grown plants and *Landscape Canada Standard* guide specification for nursery stock. All nursery stock must be viable, free from pests and disease/invasive species and undamaged. (Bylaw 1817)

14.2.2. Plant material is to be true to name, type and form and be representative of their species and variety. Plant material to be compact and properly proportioned, not weak or thin, or injured by being planted too closely in nursery rows; plant material shall have healthy tops to a size proportionate to root requirements typical of the species or variety. (Bylaw 1817)

14.2.3. Rootballs and growing medium in containers must be free of invasive and noxious plants. (Bylaw 1817)

14.2.4. Boulevard Trees (Bylaw 1817)

14.2.4.1. Boulevard trees are to be provided in the road allowance at a density of one tree per 12 lineal meters of frontage.

14.2.4.1.1. If in the assessment of the Director of Parks, Recreation and Facilities, the density of one tree per 12 lineal meters of frontage cannot be accomplished without compromising sound arboricultural practices, due to the size or other characteristics of the frontage, the developer shall pay cash-in-lieu to the City in the amount of \$1750.00 for each required boulevard tree that cannot be accommodated, to be used by the City to provide boulevard trees in other locations.

14.2.4.2. Deciduous and Broadleaf evergreen trees are to be a minimum 50 mm (2") caliper measured at 150 mm (6") from ground level and rootball to be a minimum of 600 mm (24"), alternative may be approved by the Director of Parks, Recreation and Facilities.

14.2.4.3. Coniferous trees are to be a minimum height of 3.0 m from ground level or as approved by the Director of Parks, Recreation and Facilities. For coniferous trees that are tall and columnar, the rootball is to be a minimum of 700 mm (27.5"), for tall and broad, the rootball is to be a minimum 850 mm (33.5").

14.2.4.4. Shall be planted in accordance with Schedule 11, details L1(a), L1(b), L2(a), L2(b), L2(c), L2(d), L2(e), L3(a), L3(b).

14.2.4.5. For recommended boulevard tree species, refer to Approved Product List.
(Bylaw 1817)

- 14.2.4.6. Boulevard trees should be installed when their survival is most likely, usually after construction on abutting lots has been completed. The developer is responsible for replacing any tree that dies or does not thrive during the Warranty Period.
- 14.2.4.7. All trees are to be installed at the correct level relative to the finished grade. The trunk flare shall be 25 – 50 mm (1-2”) visible after the tree has been planted.
- 14.2.4.8. All trees installed in lawn areas must have a 1.2 m (47”) diameter mulched ring that is maintained by the developer until the Parks department has issued final construction acceptance.
- 14.2.4.9. All trees planted must have burlap, rope/string, wire basket and other restricting elements removed from top 1/3 of rootball.

14.2.5. Boulevard Shrub Planting (Bylaw 1817)

- 14.2.5.1. Minimum spacing shall be based on spread at maturity. With the exception of naturalized areas, shrub size at planting shall be a minimum of 300mm height for deciduous shrubs and a spread of 450mm for coniferous shrubs or as approved by the Parks Manager. (Bylaw 1817)

14.2.6. Existing Boulevard and Frontage Trees

- 14.2.6.1. Existing or significant trees on existing or future boulevards, shall be evaluated prior to site work commencing, and shall be retained at the discretion of the Parks Manager.
- 14.2.6.2. An arborist report or tree survey may be required as part of the landscape plan, at the discretion of the Parks Manager. Existing trees to be retained must be protected with a tree protection barrier, prior to commencement of any site works. Tree Protection barrier as per Schedule 11, detail L4 or as per directed by a Certified Arborist and approved by the Director of Parks, Recreation and Facilities, is to be installed and maintained for the duration of the development.
- 14.2.6.3. Any tree that has been identified by the Director of Parks, Recreation and Facilities to be damaged to the point of replacement, must be replaced in accordance with Table 14-1 and section 14.2.6.
- 14.2.6.4. Any tree on existing or future frontage dedication that is permitted to be removed by the Director of Parks, Recreation and Facilities must be compensated for in accordance with Table 14-1 and section 14.2.6.

Table 14-1 – Tree Replacement (Bylaw 1817)

Diameter of tree to be removed, based on DBH	Tree Replacement Ratio (removed : replaced)	Cash in lieu replacement equivalent (total)
<30 cm (<11.8”)	1:2	\$3500
30 – 45 cm (11.8” – 17.7”)	1:3	\$5250
45 – 90 cm (17.7” – 35.4”)	1:4	\$7000
>90 cm (>35.4”)	Biologist replanting plan required.	Dependent on Biologist replanting plan.

14.2.7. Irrigation

Irrigation design drawing to reflect either extending existing municipal irrigation from the adjacent development or a new dedicated City water meter connection for the development offsite landscaping. (Bylaw 1817)

14.2.7.1. If the irrigation design does not reflect extending existing municipal irrigation, the Developer must supply a municipal irrigation system complete with a new dedicated water meter connection and dedicated live line power to all City boulevard trees in accordance with Schedule 10 and details within Schedule 11 (P1-P15). At the discretion of the Parks Manager, Parks will accept battery powered controllers, or a sub-meter may be supplied from a private property water source. A covenant may be required for trees in the SRW.

14.2.7.2. Metered power for the municipal irrigation system must be provided. The dedicated City water meter must service all water requirements the City may have within separated boulevards and the road allowance/frontage (i.e. municipal drip irrigation, shrub beds, etc.).

14.2.7.2.1. Sod within the road allowance/frontage (from back of sidewalk to property line) is not to be watered by the dedicated City water meter.

14.2.7.2.2. Sod within road allowance/frontage (separate boulevard - back of curb to sidewalk) is to be watered by the dedicated City water meter.

14.2.7.3. The Developer must extend the municipal irrigation system (eg, mainline stub off, lateral stub off and wiring, etc.) to the development boundary limits for future development irrigation connections. (Bylaw 1817)

14.2.8. Median Planting

14.2.8.1. Plantings for medians and at driveways, intersections, and pedestrian crossing locations and any other locations specified by the Director of Engineering where sight lines are critical must not exceed a height of 1 m (3 ft) above the existing vehicular driving surface. Density and spacing of plantings are to be approved by the Director of Parks, Recreation and Facilities.

14.2.9. Turf Grass Seeding/Sodding and Artificial Turf. (Bylaw No. 1669)

Proposed turf grass within the roadway allowance / frontage is to be considered Class 1 (lawn) as per the *Canadian Landscape Standard* and recommended to be No.1 Premium sod or No. 2 Standard. This is the minimum standard for residential and commercial. (Bylaw 1817)

- 14.2.9.1. Proposed seed, and hydroseed application methods, to be as per *Canadian Landscape Standard*. (Bylaw 1817)
- 14.2.9.2. New turf grass whether seeded or sodded shall be inspected by Parks department staff for acceptance after three (3) mowings for seed, and two (2) mowings for sod. Refer to Schedule 11, details L6(a) and L6(b).
- 14.2.9.3. Any approved application of artificial turf must be in accordance Schedule 11, details L3(a), L3(b), L3(c), L3(d), and L4(b) for artificial turf installation specifications.

14.2.9.3.1 Artificial turf product specifications shall comply with Table 14-2.

Table 14-2 – Artificial Turf Product Specification (Bylaw 1817)

Physical Property	Physical Characteristics
Pile Fiber Type	Polyethylene "U" Shape Cross Section
Thatch Fiber Type	Polyethylene
Fabric Width	15 feet
Pile Fiber Height	1 ½" – 1 5/8"
Thatch Fiber height	1" +/- 15 %
Pile Fiber Colour	Field Green / Olive Green or similar
Thatch Colour	Tan / Brown or similar
Tuft Gauge	3/8" – ½"
Tuft Bind	>7 lbs
Stitch Rate	Compliant with ASTM D5893
Grab Tear Strength	Compliant with ASTM 5034
Yarn Breaking Strength	Compliant with ASTM D2256
Backing Weight	Minimum 24 oz
Pile Fiber Weight	Minimum 45 oz
Water Permeability	Minimum 28" of rainfall per hour / sq yd
Recommended Infill	1.5 – 2 lbs per sq foot 20/40 Tan Silica Sand (Target Products)
Warranty Period	Minimum 10 years

14.2.9.3.2 All guled turf to turf connections is to be by Nordod or X-GF. (Bylaw 1817)

14.2.9.3.3 All glued turf to concrete abutment connections is to be by PL Premium Adhesive. (Bylaw 1817)

14.2.9.3.4 For Artificial turf plastic wood nailer board refer to Approved Product List and Schedule 11, details L3(a), L3(b), L3(c), L3(d), and L4(b).

- 14.2.10. Topsoil / Growing Medium (Bylaw 1817)
- 14.2.10.1. All areas designated for topsoil and blending of restored areas shall conform to the current BCSLA/BCNLA Landscape Standard and the Canadian System of Soil Classification.
 - 14.2.10.2. Topsoil / growing medium shall be free of building materials, invasive or noxious plant and their reproductive parts, non composted wood, wood waste, insect pests, plant pathogenic organisms, ice, chemical pollutants or substances at levels toxic to plants, and other extraneous materials that detract from the desirable physical and chemical properties required for landscaping purposes. (Bylaw 1817)
 - 14.2.10.3. The Parks Manager may request a topsoil/growing medium analysis be submitted, completed by an accredited commercial laboratory: CSA/ASTM/CALA (The Canadian Association for Laboratory Accreditation), prior to the delivery and installation of the topsoil. (Bylaw 1817)
 - 14.2.10.3.1. The analysis will include measurement of percent sand, fines, (silt and clay), and organic matter to total 100%, pH, lime required to achieve pH6.5, water soluble salts, total carbon to total nitrogen ration, total nitrogen and available levels of phosphorus, potassium, calcium and magnesium. (Bylaw 1817)
 - 14.2.10.3.2. The analysis shall outline the testing laboratory's recommendations for amendment, fertilizer and other required modifications to make the proposed growing medium meet *Canadian Landscape Standard* requirements. (Bylaw 1817)
 - 14.2.10.3.3. Failure to test and provide appropriate documentation of test results may be considered grounds for rejection of a proposed growing medium and may result in the removal of rejected material at the contractor's expense. (Bylaw 1817)
 - 14.2.10.3.4. The contractor shall ensure that the soil submitted for laboratory testing, as recommended by the lab, is a representative sample taken from the soil that will be delivered to the site. (Bylaw 1817)
 - 14.2.10.4. Structural soil composite shall be composed of growing medium and clear crush granular components in accordance with the following recommended base ration of materials: (Bylaw 1817)
 - 14.2.10.4.1 Ensure sufficient moisture (25% to 75% of field capacity) to provide a homogeneous mixture with consistent properties through the composite soil.

14.2.10.4.2 Peatmoss shall not be used in the preparation of structural soil (Bylaw 1817)

14.2.10.4.3 Soil component proportion by weight: (Bylaw 1817)

Growing medium	15% to 20% dry weight
Clear crush (25mm to 75mm clear crush)	80% to 85% dry weight
Hydrogel/Stabilizer*	0.01% to 0.02%

*Hydrogel/Stabilizer is applied as a soil tachifier to ensure even distribution and blending of the composnet materiasl. Refer to manufacture specifications for appropriate mixing proportions. (Bylaw 1817)

14.2.10.4.4 Growing medium properties for use as a component in structural soil shall conform to Aggregate and Granual Materials (31 05 17 MMCD 2009) specifications. Gravel graduation shall consist of 25mm to 75mm clear crush washed rock free of any foreign elements or materials.

14.2.10.4.5 Structural soil installation shall conform to Excavation, Trenching and Backfilling (31 23 01 MMCD 2009) specifications. (Bylaw 1817)

14.2.10.5. Minimum topsoil depths shall comply with Table 14-3 (Bylaw 1817)

Table 14-3 Soil depth requirements

Trees	700 mm (27.5") on all sides of root ball (bylaw 1817)
Large Shrubs	450 mm (18") depth
Small Shrubs	300 mm (12") depth
Groundcover	150 mm (6") depth
Grass	150 mm (6") depth

14.2.11. Mulch

14.2.11.1. All planting beds should be top-dressed after planting to a settled depth of 50mm with high organic low wood content mulch. (Bylaw 1817)

14.2.12. Common Fill

14.2.12.1. All common fill shall consist of granular material free of rubble or debris greater than 2mm and shall not be toxic to plant or animal life.

14.3. Construction Acceptance - Landscaping (Bylaw No. 1817)

14.3.1. Construction Acceptance – Landscaping will be issued by the Parks Manager once all the following conditions have been met: (Bylaw Nos. 1669, 1817)

- 14.3.1.1. All landscaping has been installed, inspected and approved by the Parks Manager and there are no outstanding deficiencies.
- 14.3.1.2. The required irrigation inspections as noted in Schedule 10, Section 10.7, have been completed through the installation process. The irrigation system has been confirmed fully operational with complete head to head coverage during the Construction Acceptance-Landscaping inspection and there are no outstanding deficiencies. (Bylaw 1817)
- 14.3.1.3. Record landscape and Record irrigation drawings have been submitted to and approved by the Director of Parks, Recreation and Facilities in “.dwg” and “.pdf” format.
- 14.3.1.4. A signed and sealed As Constructed Information Sheet-Landscaping has been completed and submitted to Parks and approved by the Parks Manager. As Constructed Information Sheets must be submitted separately for all roadways within the development. (Bylaw 1817)
- 14.3.1.5. A “New Installation Backflow Preventer Test Report” confirming the double check valve assembly has passed CRD inspection has been submitted to Parks. (Bylaw 1817)
- 14.3.1.6. All new turf grass seeding is fully germinated/well established and has been mowed to 200 mm height three times. (Bylaw 1817)
- 14.3.1.7. All new turf grass sod is fully knit/well established and has been mowed to 200mm height twice. (Bylaw 1817)

14.4. Construction Acceptance – Landscaping

14.4.1. Upon the issuance of Construction Acceptance – Landscaping (CA-L), Warranty and Maintenance Periods of 12 months (1 year) shall commence from the indicated inspection date as approved by the Parks Department. During the Warranty and Maintenance Periods, the Developer must:

14.4.1.1 Conduct regular maintenance of off-site landscaping;

14.4.1.2 Keep a logbook (Table 14-4 Site Maintenance Inspection Log), recording each maintenance visit, operations carried out, materials used, damage to horticultural and non-horticultural elements, and any conditions that require attention or monitoring; (template from CLSA will be included, see attached)

14.4.1.3 Provide warranty for the materials, workmanship, and services; and

14.4.1.4 All deficiencies shall be corrected at the Developer's expense.

14.4.2 The Parks department will retain 10% of the off-site landscaping bonding until the successful completion of the warranty period.

14.4.3 The Parks department, after acceptance of the repair, may elect to extend the Warranty and Maintenance Periods for the repaired item for up to one year.

14.5. Final Acceptance – Landscaping

14.5.1 Prior to Final Acceptance – Landscaping (FA-L) issuance, the offsite landscaping is to be owned and maintained by the Developer in accordance with Section 14.4.

14.5.2 Prior to Final Acceptance – Landscaping (FA-L), upon the completion of the required Warranty and Maintenance Periods and when requesting final approval, the Developer must provide all maintenance logbooks to the Parks department. A final inspection will be scheduled once the maintenance logbooks are deemed satisfactory by the Parks department.

14.5.3 Upon satisfactory review of maintenance logbooks, the Parks department will schedule a final inspection within 30 days. Final inspection is to include a representative from: City of Langford Parks Department, City of Langford's pertinent maintenance contractor, the installer, and Developer. This is to ensure transparency and consistency between inspectors and developers.

14.5.4 FA-L will be issued upon the successful completion of the Warranty and Maintenance Periods, including the rectification of any outstanding deficiencies or repairs. Any remaining bonding for off-site landscaping shall be released by the Parks department.

SCHEDULE 15

Offence	Section	Fine
Fail to adhere to the approved mitigation plan	2.5.6	\$1,000
Fail to issue required blasting notification	3.2.1	\$1,000
Fail to provide certificate of general liability insurance	3.2.3	\$1,000
Fail to issue required blasting notification	3.2.4.	\$1,000

Appendix A

Table 14-4 Site Maintenance Inspection Log

Development Address: _____		SUB/FNT Number: _____	
Inspected By: _____		Inspection Date: _____	
Business Name: _____			
Category	Status		Comments/Locations
	Good	Needs Attention	
Annuals/Seasonal Bedding			
• Plant Condition			
• Water/moisture			
• Pest/disease control			
• Cultivation			
• Weed and invasive removal/control			
• Fertilization			
Shrubs, Groundcover and Perennials			
• General Condition			
• Water/moisture			
• Pest/disease control			
• Pruning/shearing			
• Weed and invasive removal/control			
• Cultivation			
• Fertilization			
Existing and New Trees			
• General condition			
• Water/moisture			
• Pest/disease control			
• Wells/edging/mulch			
• Pruning/repair			
• Stakes/arbor ties			
• Base damage/girdling			
• Fertilization			
• Weed and invasive removal/control			
Lawns			
• General appearance			
• Mowing height			
• Water/moisture			
• Edging/trimming			
• Pest/disease control			
• Weed control			
• Fertilization			
Artificial Turf			

• General appearance			
• Weed control			
• Litter/waste removal			
• Repair			
Paved/Graveled/Bare Areas			
• Surface condition			
• Weed control			
• Curbs/stops/dividers			
Irrigation System			
• Heads/risers			
• Pressure			
• Coverage			
• Controllers and settings			
• Drip			
Drains/Ditches/Water Courses			
Non-Horticultural Element Maintenance (i.e. Paving, signage, lighting, fences, play equipment, art, etc.)			
• General appearance			
• Equipment cleaning (i.e. pressure washing and cleaning play structures)			
• Repair			
• Graffiti removal			
• Litter/waste removal			
• Garbage receptacle emptying 3 times per week			
Other			