

DISTRICT OF TOFINO

**CORPORATION OF THE
DISTRICT OF TOFINO**

**Subdivision and Development Control Bylaw No.
1201, 2014**

Effective Date – January 12, 2016

DISTRICT OF TOFINO

BYLAW NO. 1201, 2014

A bylaw to regulate and require the provision of works and services in connection with the subdivision and development of land.

WHEREAS pursuant to section 938 of the *Local Government Act*, the District may, by bylaw, regulate and require the provision of works and services in respect of the subdivision of land;

AND WHEREAS pursuant to section 939 of the *Local Government Act*, the District may require that the owner of land that is to be subdivided or developed provide excess or extended services;

AND WHEREAS pursuant to section 944 of the *Local Government Act*, the minimum highway frontage of a parcel being created by a subdivision that fronts on a highway is the greater of 10% of the perimeter of the lot that fronts on the highway, and the minimum frontage contained within the zoning regulations;

NOW THEREFORE the Council of the District of Tofino, in open meeting assembled, enacts as follows:

1. Citation

This bylaw may be cited as "Subdivision and Development Control Bylaw No. 1201, 2014".

2. Definitions

In this bylaw,

"Approving Officer" means the person appointed to that position under the *Land Title Act*.

"Developer" means, as the context requires, the owner of land in respect of which a subdivision application or building permit application has been made.

"Excess and extended services" means excess and extended services as defined in section 939 of the *Local Government Act*.

"Superintendent" means the Manager of Public Works appointed to that position by the Council, and any consulting professional engineer or other person who may be appointed by the Superintendent to perform the duties and exercise the authority of the Superintendent under this bylaw.

"Security" means cash or a clean, unconditional, irrevocable and automatically renewing letter of credit drawn on a chartered bank or credit union having a branch in the District at which demand may be made on the letter of credit.

“Warranty Period” means a one-year period commencing on the date the Superintendent issues an Initial Certificate of Acceptance of works and services constructed or provided pursuant to this bylaw.

3. Subdivision Administration

No person shall subdivide land in the District unless the works and services required by this bylaw have been provided by the Developer to the satisfaction of the Superintendent, or the Developer has entered into an agreement with the District to construct and install the required works and services by a date specified in the agreement, and provided to the District Security in the amount of 125% of the estimated cost of the works and services, and associated professional fees as determined by the Superintendent on the basis of information provided by the Developer’s consulting engineer.

4. Subdivision Exemptions

Section 3 does not apply:

4.1. to a subdivision creating a single parcel to be used solely for the installation or placement of unattended equipment necessary for the operation of a community water system, community sewer system, gas distribution system, district heating system, telecommunications facility, air navigational aid, electrical substation or power generating station, or any other similar public service facility, if the subdivider grants a covenant to the District under s. 219 of the *Land Title Act* limiting the use of the parcel to that use;

4.2. to a subdivision creating a parcel to be used as a park or playground; or

4.3. in cases where the Superintendent determines that the need for the works or services is not directly attributable to the subdivision, or to buildings likely to be constructed in the subdivision.

5. Development Administration

No person shall construct a building or structure in the District for which a building permit is required unless the works and services required by this bylaw have been provided by the Developer to the satisfaction of the Superintendent, or the Developer has entered into an agreement with the District to construct and install the required works and services by a date specified in the agreement, and provided to the District Security in the amount in the amount of 125% of the estimated cost of the works and services as determined by the Superintendent on the basis of information provided by the Developer’s consulting engineer.

6. Development Exemption

Section 5 does not apply in cases where the Superintendent determines that the need for the works or services is not directly attributable to the building for which a building permit application has been made.

7. Warranty

In cases where works and services required by this bylaw are constructed prior to the approval of a subdivision or the issuance of a building permit and the Superintendent has issued an Initial Certificate of Acceptance, the subdivision must not be approved and the building permit must not be issued unless the Developer enters into an agreement with the District to maintain, correct defects in and repair the works at the Developer's cost throughout the Warranty Period.

8. Works and Service Agreement

The Superintendent may:

8.1. from time to time, prescribe the form of agreement referred to in sections 3 and 5, provided that each such agreement shall:

8.1.1. require the Developer to maintain repair and make good all defects and deficiencies appearing in the works and services during the Warranty Period;

8.1.2. enable the Developer to request that the Superintendent permit reductions in the amount of the Developer's Security based on the Developer's professional engineer's written estimate of the cost to complete the remaining works and services, provided that no such reductions shall result in the reduction of the amount of the Security below 80% of the amount originally provided;

8.1.3. require the Developer to provide to the District throughout the Warranty Period performance Security in the amount determined by the Superintendent, which amount may not exceed 10% of the amount provided in relation to the construction of the works and services;

8.1.4. require the Developer to carry third party liability insurance in an amount and form acceptable to the District Solicitor, in respect of claims arising out of death, personal injury or damage arising from the construction of the works and services on District highways or statutory rights of way; and

8.1.5. require the Developer to indemnify the District and save it harmless in respect of all costs and expenses it may incur as a result of faulty workmanship or defective material in the works and services in respect of which the District has provided notice to the Developer prior to the District's final acceptance of the works and services;

8.2. from time to time, prescribe the form of agreements referred to in section 7;

8.3. execute and deliver all such agreements on behalf of the District, and

8.4. require that such agreements be drafted in a form that is registrable under s. 219 of the *Land Title Act* against title to the land being subdivided or built upon.

9. Required Works and Services

The works and services required by this bylaw are the following:

- 9.1. highways and lanes, boulevards including street trees and other landscaping, boulevard crossings, culverts, transit bays, sidewalks, walkways, highway and walkway bridges, curbs and gutters, traffic signs and signals, street lighting and conduit and vaults for underground wiring;
- 9.2. water distribution systems connected to the District's water distribution system including, without limitation, fire hydrant systems, valves and valve chambers, meters and meter chambers, pump stations and reservoirs;
- 9.3. sewage collection systems connected to the District's sewage collection system including, without limitation, lift stations, manholes and sewage holding facilities; and
- 9.4. drainage collection systems connected to the District's drainage collection system including, without limitation, enclosed storm sewers, catch basins, manholes, ditches, gates, stormwater retention and detention facilities, and environmental control facilities.

10. Provision of Works and Services

The works and services described in section 9 that are provided on highways or lanes must, in all cases, be provided on that portion of the highway or lane immediately adjacent to the parcel that is the subject of the subdivision or building permit application, as the case may be, unless additional requirements are imposed under section 16.

11. Standards for Works and Services

The works and services required by sections 3 and 5 and under section 16 must be constructed and installed at the cost of the Developer to the standards and specifications set out in Schedules A through F attached to this bylaw, except to the extent that such standards or specifications may have been varied by development variance permit or board of variance order, and in accordance with Master Municipal Construction Documents and Tofino Supplementary Design Standards as amended from time to time.

12. Existing Works and Services

If works and services of the type described in section 9 are already in existence on or in the highway or lane adjacent to a parcel being subdivided or on which a building is proposed to be constructed, and the works and services do not comply with the standards specified in section 11, the Developer must alter the works and services so that they comply with the standards, and the provisions of sections 3 and 5 regarding agreements and Security apply to the alterations.

13. Cash in Lieu of Works and Services

The Superintendent may require a Developer to pay to the District, in lieu of constructing or altering works and services required by this bylaw, cash in the amount determined by the Director to be the cost of constructing or altering the works and services as of the time of approval of the subdivision or issuance of the building permit, if the Director determines on the basis of sound civil engineering

practice or cost considerations that the works should be constructed or altered at a later time or concurrently with the construction or alteration of works and services serving adjacent or nearby parcels of land. In such cases the District shall deposit the funds into a reserve fund established for the construction or alteration of the works and services.

14. Location of Works and Services

The works and services required by this bylaw shall be provided in dedicated highways, unless the Superintendent has approved the location of the works and services in a statutory right of way granted to the District, in which case the statutory right of way, including any required plan of right of way, must be prepared at the cost of the Developer, in terms satisfactory to the Superintendent and the District Solicitor, and deposited concurrently with the deposit of the subdivision plan in the case of a subdivision application and prior to the issuance of an occupancy permit in the case of a building permit application.

15. Dedication of Works and Services

Title to all works and services constructed in District highways or statutory rights of way or land to be dedicated as District highways or granted to the District as statutory rights of way, shall pass to the District upon the later of the date of dedication of the highway or deposit of the statutory right of way in the Land Title Office, and the date on which the Superintendent issues an Initial Certificate of Acceptance in respect of the works and services, but transfer of title to the works and services shall not affect the obligation of the Developer to maintain, correct defects in or repair the works and services under this bylaw or any servicing agreement.

16. Delegation

The Council delegates to the Superintendent the powers of the Council under the *Local Government Act* to:

- 16.1. require a Developer to construct excess or extended services;
- 16.2. determine whether the cost to the District to provide the excess or extended services would be excessive and, in that event, that the cost must be paid by the Developer;
- 16.3. determine the benefit of the excess or extended service that may be attributed to each of the parcels of land that will be served by the services; and
- 16.4. impose latecomer charges under section 939 of the Act including interest at the rate of 10 percent per annum.

17. Execution of Works and Services Agreements

For the purpose of section 16, the Superintendent may execute and deliver on behalf of the District agreements with Developers regarding the collection and remittance of latecomer charges, which agreements may be combined with works and services agreements as referred to in sections 3 and 5.

18. Design Standards

Prior to constructing the works and services required by this bylaw, the Developer shall cause to be prepared by a professional engineer who is a member of the Association of Professional Engineers and Geoscientists of British Columbia, for the approval of the Superintendent, plans and specifications for the works that comply with Schedules A through F attached to this bylaw and the Master Municipal Construction Documents and Tofino Supplementary Design Standards, and a certified estimate of the cost of the works and services for the purposes of section 3 or 5 and section 20 of this bylaw. Any portions of the works and services that are not contained in dedicated highways or highways to be dedicated to the District shall be located in statutory rights of way previously granted to the District or to be granted to the District at the Developer's cost.

19. Excess or Extended Works and Services

The Superintendent may require the Developer, for the purpose of section 16 of this bylaw, to include in the plans and specifications referred to in section 18 excess or extended services; separate certified estimates of the cost of the excess or extended services; a plan showing the parcels of land other than the Developer's parcel that the Developer's engineer considers would derive a benefit from the excess or extended services; and a proposal for equitably allocating the cost of the excess or extended services among the benefiting parcels. The engineer's proposals as to benefiting parcels and cost allocations shall not be binding on the Superintendent.

20. Administration Fees

An applicant for a subdivision or building permit who is required to construct works and services required by this bylaw shall pay a works and services administration and inspection fee at the time of final approval of the subdivision or issuance of the building permit, in the amount of 4% of the estimated cost of the works and services referred to in section 3, provided that if the estimated cost is more than \$500,000 and less than \$1,000,000 the fee shall be \$20,000 plus 3% of the estimated cost above \$500,000 and if the estimated cost is \$1,000,000 or more the fee shall be \$35,000 plus 2% of the estimated cost above \$1,000,000.

21. Minimum Parcel Frontage

The minimum frontage of a parcel that fronts on a highway is the greater of 1/10 of the perimeter of the parcel and the parcel width required under the building bulk and siting regulations enacted in the zoning bylaw for the zoning district in which the parcel is located.

22. Repeal

Subdivision and Development Bylaw No. 850, 2000 and all amendments thereto are hereby repealed.

23. Severability

If a portion of this bylaw is held invalid by a Court of competent jurisdiction, then the invalid portion must be severed and the remainder of this bylaw is deemed to have

been adopted without the severed section, subsection, paragraph, subparagraph, clause or phrase.

READ A FIRST TIME on September 9th, 2014

READ A SECOND TIME on December 8, 2015

AMENDED on December 8, 2015

READ A THIRD TIME AS AMENDED on December 8, 2015

ADOPTED on January 12, 2016



Josie Osborne, Mayor



Robert MacPherson, Corporate Officer

Schedule 'A' - District of Tofino - Road Cross-Sections

Subdivision and Development Control Bylaw No. 1201, 2014

Refer to Map 7 "Road Typologies" in the Official Community Plan for road designation.

- A1 – Primary Arterial
- A2 – Gateway Arterial
- A3 – Downtown Arterial
- C1 – Downtown Collector
- C2 – Village Collector
- C3 – Industrial Collector
- C4 – Recreational Access Collector
- C5 – Residential Collector
- L1 – Downtown Local (Not Included)
- L2 – Village Local
- L3 – Residential Local
- L4 – Village Rear Lane Local
- L5 – Cul-De-Sac Local

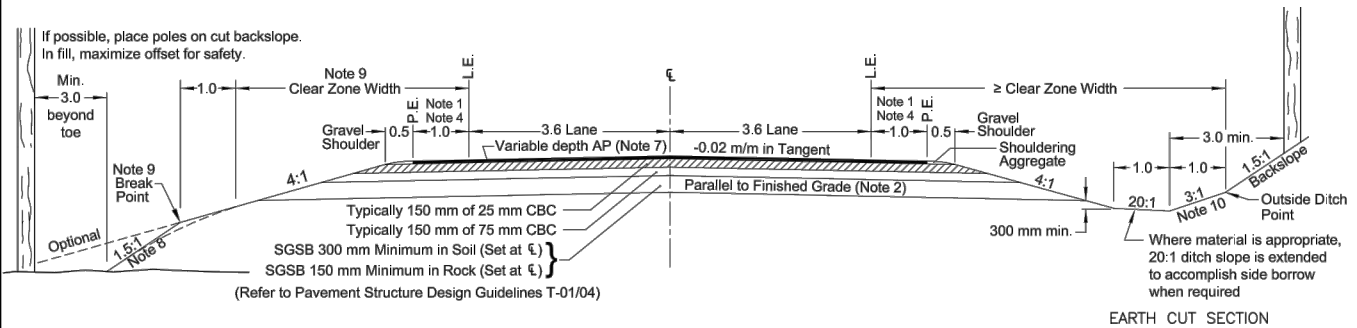

Notes:

1. See Table 430.A for lane and shoulder widths.
2. Tangent subgrade may be increased to -0.03 or -0.04 m/m in earth to facilitate drainage, but only when directed by Geotechnical Staff.
3. For rock ditch details, see Figure 440.H
4. For roadside barrier, 1.3 m is required to the nearest edge of barrier.
5. These are typical gravel depths to be used in the absence of geotechnical investigation.
6. Design Speeds 50 - 80 km/h.
7. Typically Type 'B' or Type 'C' Pavement Design. (see Technical Circular T-01/04)
8. Fill slopes should be as flat as possible and no steeper than 1.5:1. Desirable is 4:1 or flatter.
9. Clear Zone Width to be in accordance with the requirements in Section 620. Rounding or "smoothing" at Break Point to be done during construction.
10. The 3:1 ditch slope is not mandatory. A single backslope may be used starting at the low point of the ditch.

Terms:

- AP Asphalt Pavement
- CBC Crushed Base Course
- SGSB Select Granular Sub Base
- L.E. Lane Edge
- P.E. Pavement Edge

Reference:

BC Ministry of Transportation and Infrastructure - Supplement to TAC Geometric Design Guide
Figure 440.A Typical Section - Rural Local Undivided

| | | | | | |
|---|---|---|----------|---------------------------------------|------------|
| 3 | | All Dimensions Shown in Metres, Unless Otherwise Noted | | | |
| 2 | | | | | |
| 1 | | | | | |
| | Revision Date | Approved | Title | A1 PRIMARY ARTERIAL STREET SECTION | |
|  DISTRICT OF TOFINO | SUBDIVISION & DEVELOPMENT CONTROL BYLAW | | Approved | DRAWING NUMBER A1 | |
| | | | Date | | JAN 2014 |
| | | | Drawn By | | McElhanney |

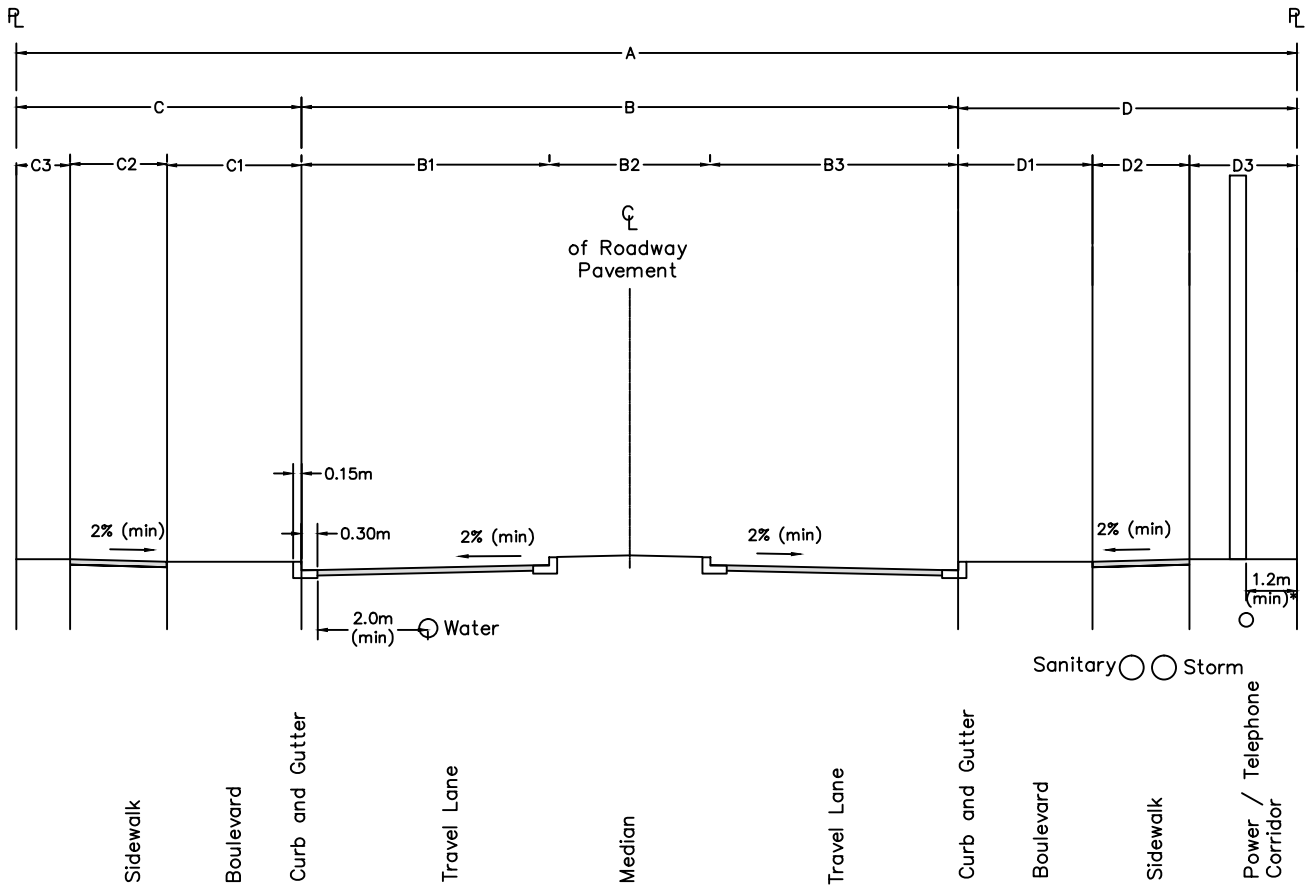

* Minimum dimension from edge of property line to power / telephone pole is 1.2m; 1.8m is desirable where sufficient ROW available

| | | | | | |
|---|---|---|--|-------------------------------|-------------------|
| 3 | | All Dimensions Shown in Metres, Unless Otherwise Noted | | | |
| 2 | | | | | |
| 1 | | | | | |
| | Revision Date | Approved | Title A2 GATEWAY ARTERIAL STREET SECTION (Page 1 of 2) | | |
|  DISTRICT OF TOFINO | SUBDIVISION & DEVELOPMENT CONTROL BYLAW | | Approved | DRAWING NUMBER A2.1 | |
| | | | Date | | November 2011 |
| | | | Drawn By | | Bunt & Associates |

| Minimum Dimensions | | | | | | | | | | | | | | | | | | |
|--------------------|--|--|--|--|--------------------|-------|------|------|---------|------|------|------|---------|------|------|------|---------|------|
| Code | Name | Streetlighting Provision | Cyclist & Pedestrian Provision | Left Turn Bay Provision | A | B | | | Total B | C | | | Total C | D | | | Total D | |
| | | | | | | B1 | B2 | B3 | | C1 | C2 | C3 | | D1 | D2 | D3 | | |
| A2.1 | Arterial Gateway: Campbell from Gibson Street to Fourth Street | Decorative street lighting at intersections only | Shared 4.6m Lanes; Sidewalks both sides | No Left Turn Bay | 17.10 | 4.60 | 0.00 | 4.60 | 9.2 | 1.20 | 1.50 | 0.50 | 3.20 | 1.20 | 1.50 | 2.00 | 4.70 | |
| | | | | With Left Turn Bay | 20.40 | 6.25 | 0.00 | 6.25 | 12.5 | 1.20 | 1.50 | 0.50 | 3.20 | 1.20 | 1.50 | 2.00 | 4.70 | |
| | | | | 1.5m Bicycle Lanes; Sidewalks both sides | No Left Turn Bay | 18.90 | 5.50 | 0.00 | 5.50 | 11.0 | 1.20 | 1.50 | 0.50 | 3.20 | 1.20 | 1.50 | 2.00 | 4.70 |
| | | | | | With Left Turn Bay | 22.40 | 7.25 | 0.00 | 7.25 | 14.5 | 1.20 | 1.50 | 0.50 | 3.20 | 1.20 | 1.50 | 2.00 | 4.70 |
| A2.2 | Arterial Gateway: from Village Containment Boundary to Gibson | Decorative street lighting at intersections only | Sidewalk: one side; shared off-street multi-use pathway other side | No Left Turn Bay | 16.60 | 3.70 | 0.00 | 3.70 | 7.4 | 1.20 | 1.50 | 0.50 | 3.20 | 1.00 | 3.00 | 2.00 | 6.00 | |
| | | | | With Left Turn Bay | 20.10 | 5.45 | 0.00 | 5.45 | 10.9 | 1.20 | 1.50 | 0.50 | 3.20 | 1.00 | 3.00 | 2.00 | 6.00 | |
| | | | | No Left Turn Bay | 18.60 | 3.70 | 0.00 | 3.70 | 7.4 | 1.20 | 1.50 | 0.50 | 3.20 | 1.00 | 3.00 | 2.00 | 6.00 | |
| | | | | With Left Turn Bay | 20.10 | 5.45 | 0.00 | 5.45 | 10.9 | 1.20 | 1.50 | 0.50 | 3.20 | 1.00 | 3.00 | 2.00 | 6.00 | |

| Desireable Dimensions | | | | | | | | | | | | | | | | | | |
|-----------------------|--|--|--|--|--------------------|-------|------|------|---------|------|------|------|---------|------|------|------|---------|------|
| Code | Name | Streetlighting Provision | Cyclist & Pedestrian Provision | Left Turn Bay Provision | A | B | | | Total B | C | | | Total C | D | | | Total D | |
| | | | | | | B1 | B2 | B3 | | C1 | C2 | C3 | | D1 | D2 | D3 | | |
| A2.1 | Arterial Gateway: Campbell from Gibson Street to Fourth Street | Decorative street lighting at intersections only | Shared 4.6m Lanes; Sidewalks both sides | No Left Turn Bay | 23.80 | 4.60 | 3.00 | 4.60 | 12.2 | 2.50 | 1.80 | 1.00 | 5.30 | 2.50 | 1.80 | 2.00 | 6.30 | |
| | | | | With Left Turn Bay | 24.30 | 6.35 | 0.00 | 6.35 | 12.7 | 2.50 | 1.80 | 1.00 | 5.30 | 2.50 | 1.80 | 2.00 | 6.30 | |
| | | | | 1.5m Bicycle Lanes; Sidewalks both sides | No Left Turn Bay | 25.60 | 5.50 | 3.00 | 5.50 | 14.0 | 2.50 | 1.80 | 1.00 | 5.30 | 2.50 | 1.80 | 2.00 | 6.30 |
| | | | | | With Left Turn Bay | 28.10 | 7.25 | 0.00 | 7.25 | 14.5 | 2.50 | 1.80 | 1.00 | 5.30 | 2.50 | 1.80 | 2.00 | 6.30 |
| A2.2 | Arterial Gateway: from Village Containment Boundary to Gibson | Decorative street lighting at intersections only | Sidewalk: one side; shared off-street multi-use pathway other side | No Left Turn Bay | 24.20 | 3.70 | 3.00 | 3.70 | 10.4 | 2.50 | 1.80 | 1.00 | 5.30 | 2.50 | 4.00 | 2.00 | 8.50 | |
| | | | | With Left Turn Bay | 24.70 | 5.45 | 0.00 | 5.45 | 10.9 | 2.50 | 1.80 | 1.00 | 5.30 | 2.50 | 4.00 | 2.00 | 8.50 | |
| | | | | No Left Turn Bay | 24.20 | 3.70 | 3.00 | 3.70 | 10.4 | 2.50 | 1.80 | 1.00 | 5.30 | 2.50 | 4.00 | 2.00 | 8.50 | |
| | | | | With Left Turn Bay | 24.70 | 5.45 | 0.00 | 5.45 | 10.9 | 2.50 | 1.80 | 1.00 | 5.30 | 2.50 | 4.00 | 2.00 | 8.50 | |

Notes:

- Minimum dimensions only to be used in retrofit situations where ROW severely constrained. Minimum desirable ROW is 20.0m; if minimum dimensions used, any surplus ROW should be allocated to achieve Desirable dimensions in following priority: C2/D2; C1/D1, C3/D3, B2
- If insufficient ROW is available to achieve even Minimum Dimensions, some dimensions can be reduced further as approved by MoTI and District of Tofino as follows:

| Location | Absolute Minimum Dimension |
|----------|---|
| B1, B2 | 4.5m with shared lanes; 3.6 with MUP |
| D1 | 0.5m next to multi-use pathway |
| D2 | 2.4m when MUP in cross section |
| D3 | Can be reduced to 0.5m if power poles in D3 corridor; but C3 corridor then must be widened to at least 2.0m |

- If sufficient ROW is available to exceed Desirable Dimensions, some dimensions can be increased as follows:

| Location | Potential Increased Dimension |
|----------|---|
| B1, B2 | Provide 1.5m bicycle lanes instead of 4.3m shared vehicle/bike lanes |
| C1, D1 | Clearance between curb and ped/bike facilities can be increased as per Note 4 |
| C3, D3 | If C1 and D1 dimensions are maximized, surplus ROW can allocated to C3 and D3 |

- For C1/D1 corridors: 1.2m requires hard surface or gravel; with 1.5m a grass boulevard can be provided; at >1.5m other landscaping is possible and > 2.5m street trees feasible as approved by MoTI and DOT. Sustainable drainage facilities also possible in C1/D1 corridors if sufficient ROW available
- Required minimum C3 and D3 dimensions may be governed by cut/fill or requirement to match to existing conditions
- Sidewalks and multi-use pathway may have to meander to avoid power poles; if a sidewalk shifts next to curb, C1 and D1 dimension reduces to 0.8m and sidewalk/pathway must widen by 0.6m
- B1 Desirable Dimension for shared vehicle/bike lanes accounts for 4.3m minimum shared travel lane width and 0.30m gutter pan
- If ROW available, raised median in B2 corridor should be considered, particularly on approach to Downtown to assist in speed management and at intersection with Gibson to provide pedestrian/cyclist crossing refuge. Impact on driveways must be considered. Median width includes non-mountable curbs and can range from 1.3m minimum (hard surface) to 3.0m (with trees). No median assumed when left turn bay present, although 1.3m wide hard surface median possible

| | | | | | |
|---|--------------------|---|--|-------------------------------|-------------------|
| 3 | | All Dimensions Shown in Metres, Unless Otherwise Noted | | | |
| 2 | | | | | |
| 1 | | | | | |
| | Revision Date | Approved | Title A2 GATEWAY ARTERIAL STREET SECTION (Page 2 of 2) | | |
| | | | | | |
|  | DISTRICT OF TOFINO | SUBDIVISION & DEVELOPMENT CONTROL BYLAW | Approved | DRAWING NUMBER A2.2 | |
| | | | Date | | November 2011 |
| | | | Drawn By | | Bunt & Associates |

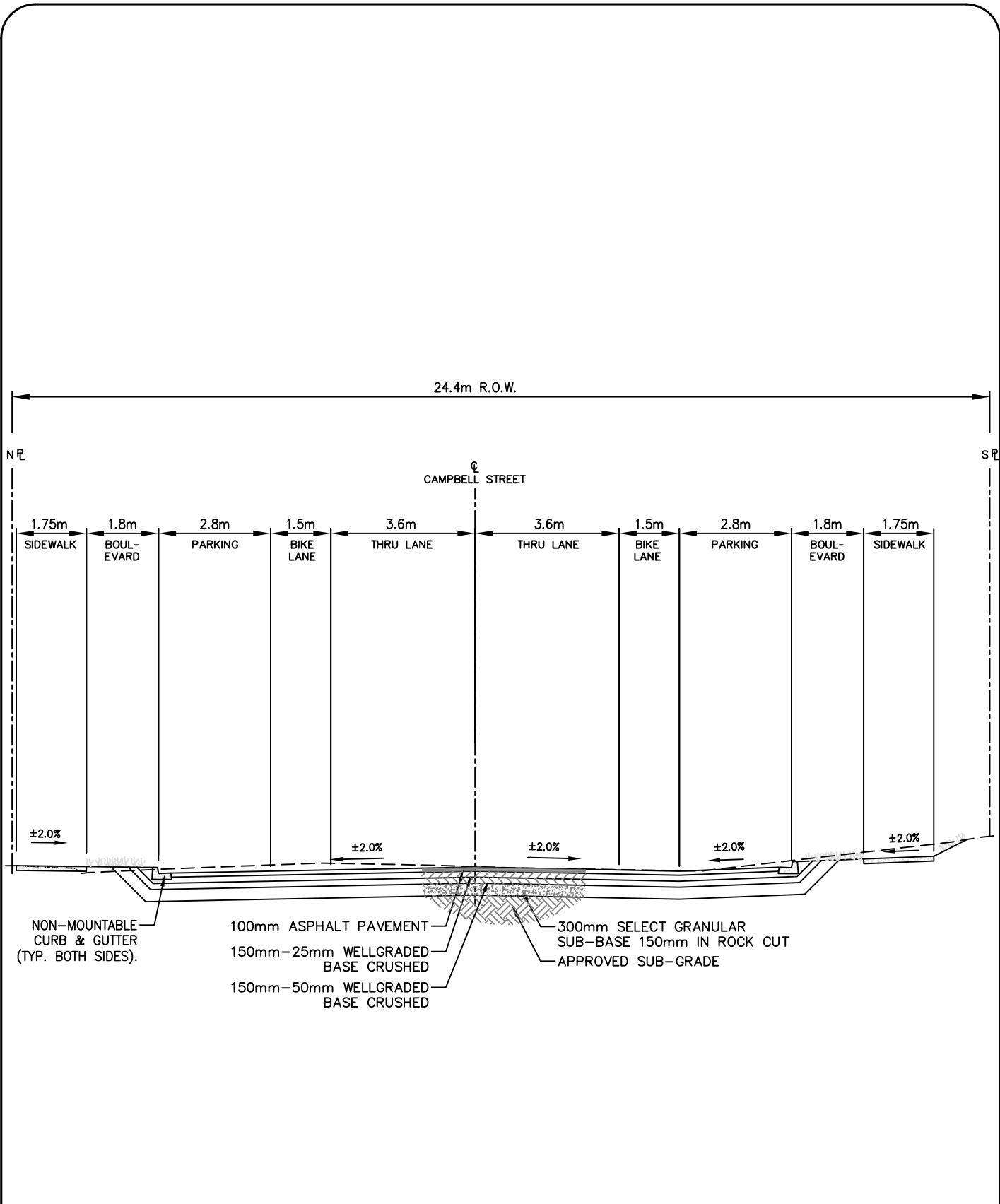

| | | |
|---------------|----------|---|
| 3 | | All Dimensions Shown in Metres, Unless Otherwise Noted |
| 2 | | |
| 1 | | |
| Revision Date | Approved | Title A3 DOWNTOWN ARTERIAL STREET SECTION |

| | | | |
|--|--|--|-----------------------------|
| | DISTRICT OF TOFINO SUBDIVISION & DEVELOPMENT CONTROL BYLAW | Approved Date JAN 2014 Drawn By McElhanney | DRAWING NUMBER A3 |
|--|--|--|-----------------------------|

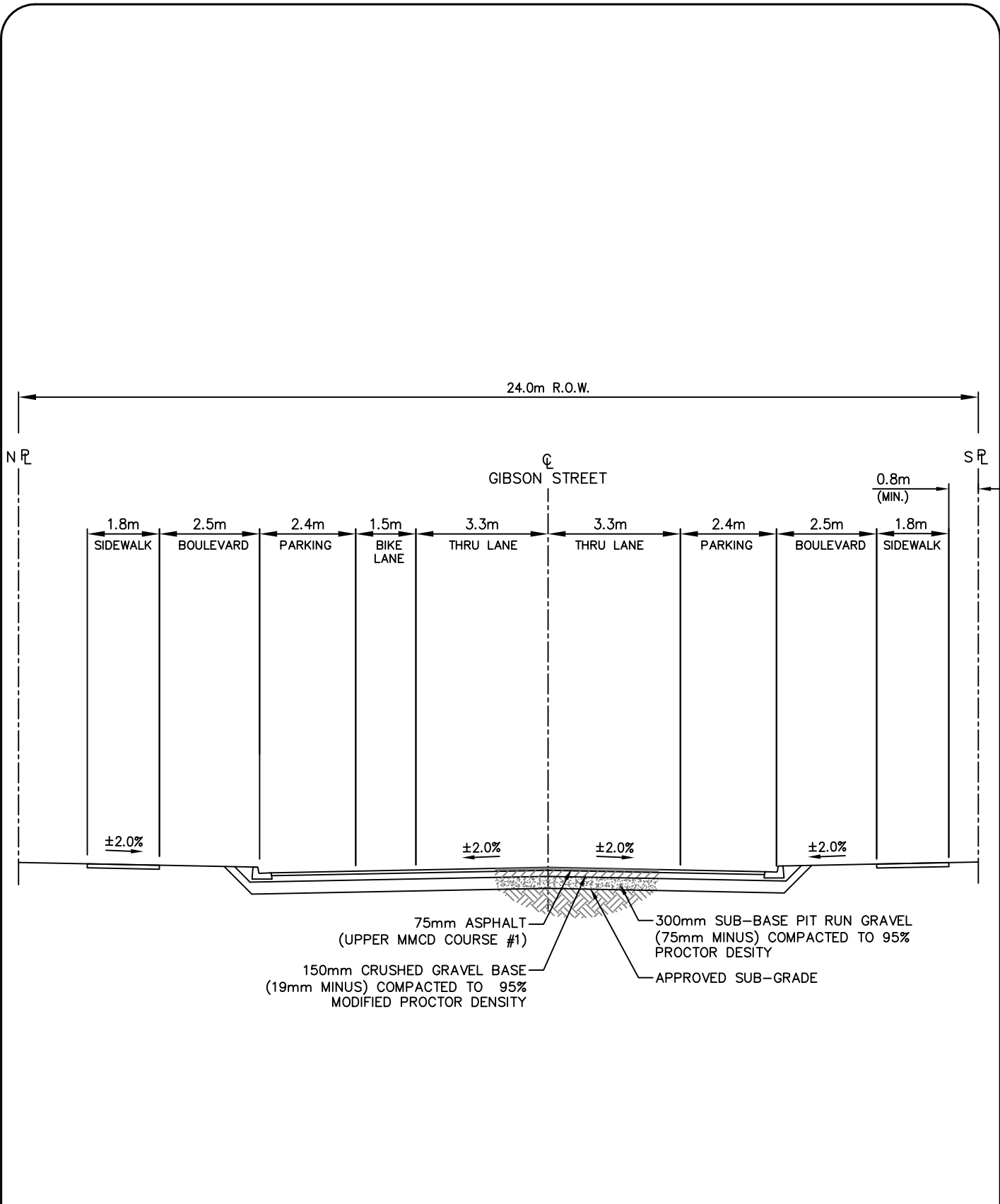

| | | | |
|---|---------------|---|--|
| 3 | | All Dimensions Shown in Metres, Unless Otherwise Noted | |
| 2 | | | |
| 1 | | | |
| | Revision Date | Approved | Title C1 DOWNTOWN COLLECTOR STREET SECTION |



DISTRICT OF TOFINO SUBDIVISION & DEVELOPMENT CONTROL BYLAW

| | |
|----------|------------|
| Approved | |
| Date | JAN 2014 |
| Drawn By | McElhanney |

DRAWING NUMBER
C1

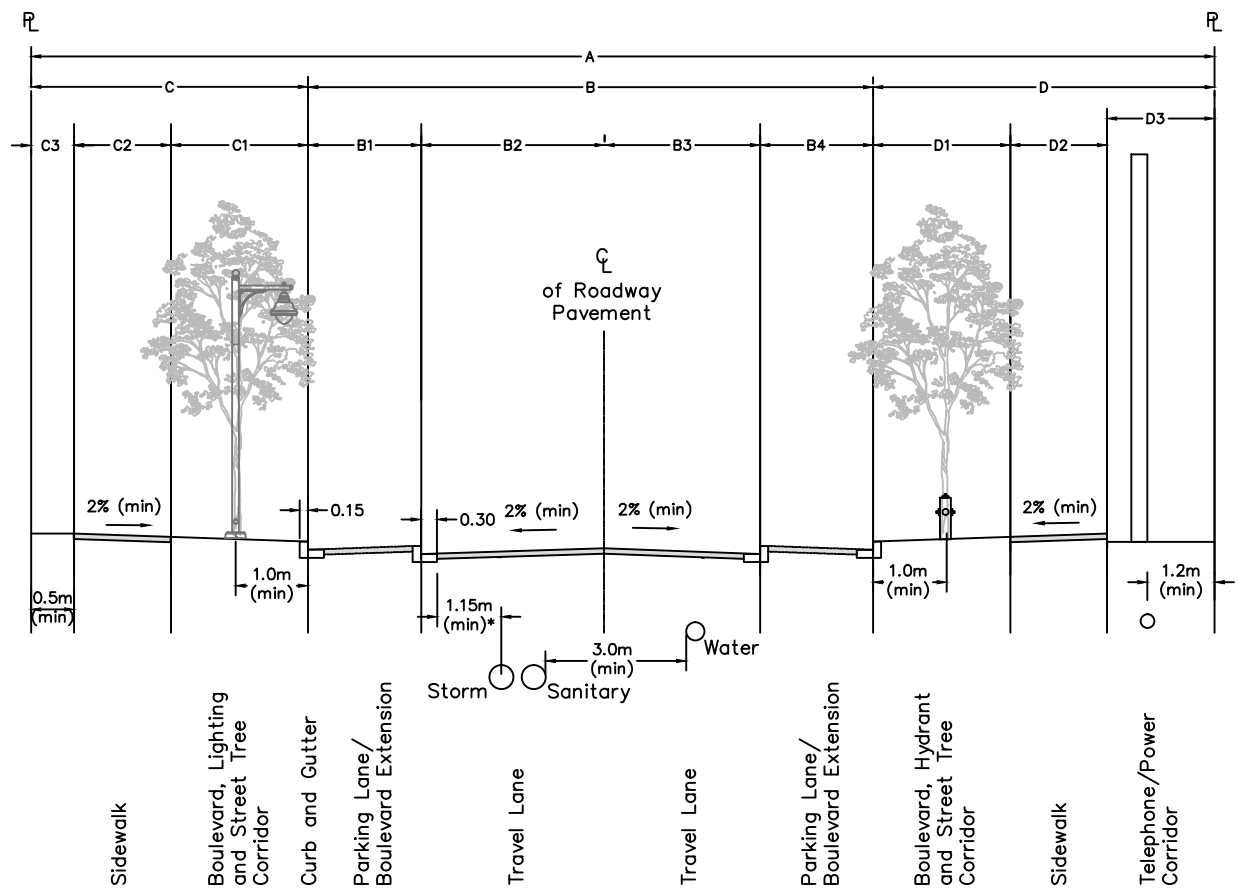

* Minimum dimension from water line to edge of gutter is 1.15m on cross sections with narrow B dimensions; 2.0m is desirable for all other cross sections.

| Code | Name | Parking/ Traffic Operation | Blvd. | Dimensions | | | | | | | | | | | | | |
|------|-------------------------|-------------------------------|-------|------------|------|------|------|-------|---------|------|------|------|---------|------|------|------|---------|
| | | | | A | B | | | | | C | | | | D | | | |
| | | | | | B1 | B2 | B3 | B4 | Total B | C1 | C2 | C3 | Total C | D1 | D2 | D3 | Total D |
| C2.1 | Urban Village Collector | No Parking | Grass | 16.0 | 0.00 | 3.50 | 3.50 | 0.00 | 7.00 | 1.50 | 1.80 | 1.20 | 4.50 | 1.50 | 0.00 | 3.00 | 4.50 |
| | | | Treed | 18.0 | 0.00 | 3.50 | 3.50 | 0.00 | 7.00 | 3.00 | 1.80 | 0.70 | 5.50 | 3.00 | 0.00 | 2.50 | 5.50 |
| | | Parking One Side | Grass | 16.0 | 2.40 | 3.30 | 3.30 | 0.00 | 9.00 | 1.35 | 1.80 | 0.50 | 3.65 | 1.35 | 0.00 | 2.00 | 3.35 |
| | | | Treed | 20.0 | 2.40 | 3.30 | 3.30 | 0.00 | 9.00 | 3.00 | 1.80 | 0.70 | 5.50 | 3.00 | 0.00 | 2.50 | 5.50 |
| | Parking Both Sides | Grass | 22.0 | 2.40 | 3.30 | 3.30 | 2.40 | 11.40 | 1.50 | 1.80 | 2.00 | 5.30 | 1.50 | 1.80 | 2.00 | 5.30 | |
| | | Treed | 24.0 | 2.40 | 3.30 | 3.30 | 2.40 | 11.40 | 2.70 | 1.70 | 1.80 | 6.20 | 2.70 | 1.70 | 2.00 | 6.40 | |

| | | | | |
|---|---------------|----------|---|-------------------|
| 3 | | | All Dimensions Shown in Metres, Unless Otherwise Noted | |
| 2 | | | | |
| 1 | | | | |
| | Revision Date | Approved | Title C2 VILLAGE COLLECTOR STREET SECTIONS | |
| DISTRICT OF TOFINO SUBDIVISION & DEVELOPMENT CONTROL BYLAW | | | | |
| | | | | Approved |
| | | | Date | November 2011 |
| | | | Drawn By | Bunt & Associates |

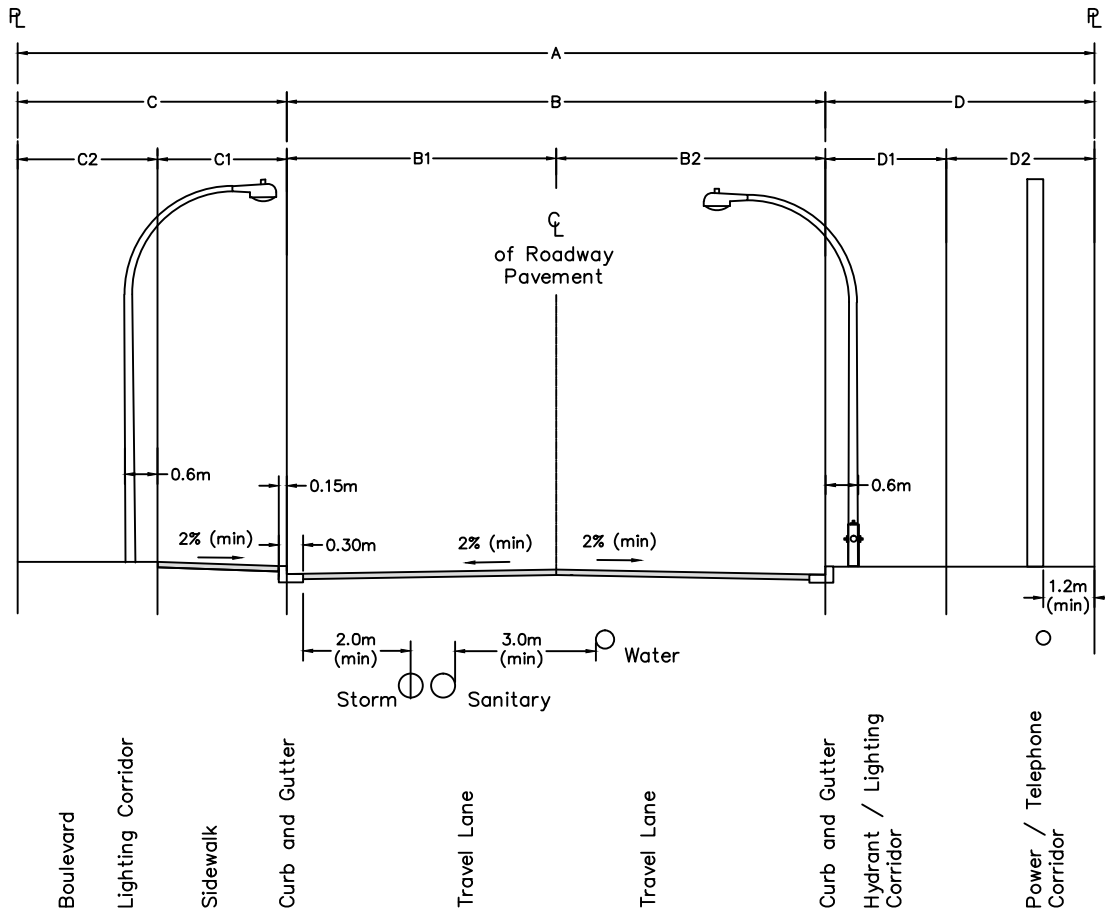

| | | Minimum Dimensions | | | | | | | | | |
|------|----------------------------|--------------------|------|------|---------|------|------|---------|------|------|---------|
| Code | Name | A | B | | | C | | | D | | |
| | | | B1 | B2 | Total B | C1 | C2 | Total C | D1 | D2 | Total D |
| C3 | Urban Industrial Collector | 20.00 | 5.00 | 5.00 | 10.0 | 2.40 | 2.60 | 5.00 | 2.25 | 2.75 | 5.00 |

Notes:

1. Parking not permitted
2. Grass or gravel boulevard as directed by District of Tofino
3. Non-mountable curb required
4. Street section accommodates hydro poles or underground power with LPT in D corridor
5. Standard davit street light poles on both sides

| | | | | | |
|---|---|---|--|-----------------------------|-------------------|
| 3 | | All Dimensions Shown in Metres, Unless Otherwise Noted | | | |
| 2 | | | | | |
| 1 | | | | | |
| | Revision Date | Approved | Title C3 INDUSTRIAL COLLECTOR STREET SECTION | | |
|  DISTRICT OF TOFINO | SUBDIVISION & DEVELOPMENT CONTROL BYLAW | | Approved | DRAWING NUMBER C3 | |
| | | | Date | | November 2011 |
| | | | Drawn By | | Bunt & Associates |

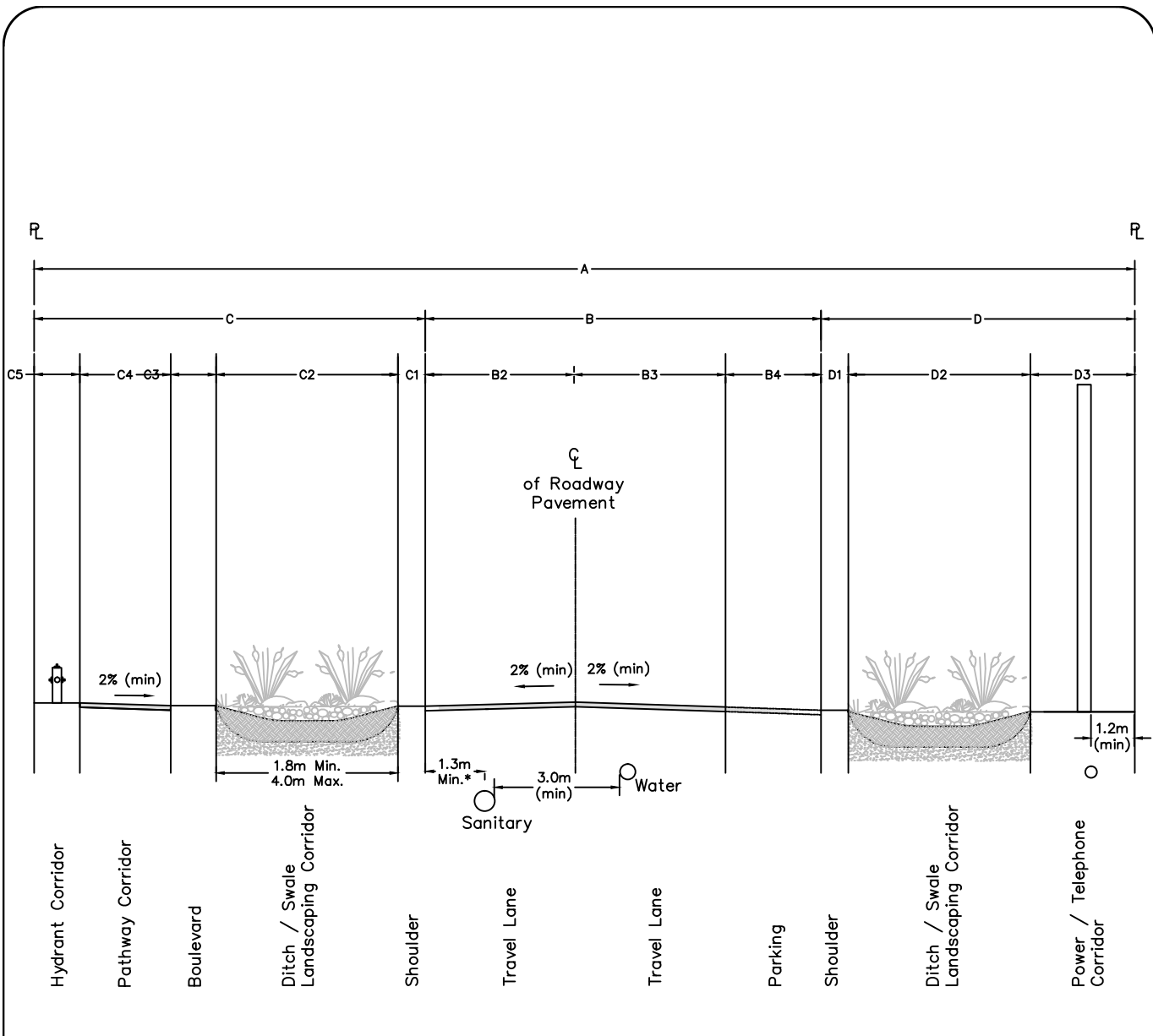

* Minimum dimension from water line to edge of flush curb is 1.3m for cross sections with narrow B dimensions; 2.0m desirable for all other sections

| Code | Name | Parking/ Traffic Operation | Drainage | Dimensions | | | | | | | | | | | | | | | |
|------|--|----------------------------------|------------|------------|------|------|------|------|---------|------|------|------|------|------|---------|------|------|------|---------|
| | | | | A | B | | | | | C | | | | | D | | | | |
| | | | | | B1 | B2 | B3 | B4 | Total B | C1 | C2 | C3 | C4 | C5 | Total C | D1 | D2 | D3 | Total D |
| C4 | Rural Recreational Access Collector | No Parking | Min. Ditch | 20.0 | 0.00 | 3.50 | 3.50 | 0.00 | 7.0 | 0.60 | 1.80 | 1.00 | 3.00 | 1.00 | 7.40 | 0.60 | 1.80 | 3.20 | 5.60 |
| | | | Max. Swale | 24.0 | 0.00 | 3.50 | 3.50 | 0.00 | 7.0 | 0.60 | 4.00 | 1.00 | 3.00 | 1.00 | 9.60 | 0.60 | 4.00 | 2.80 | 7.40 |
| | | Parking One Side (Parallel) | Min. Ditch | 22.0 | 0.00 | 3.45 | 3.45 | 2.10 | 9.0 | 0.60 | 1.80 | 1.00 | 3.00 | 1.00 | 7.40 | 0.60 | 1.80 | 3.20 | 5.60 |
| | | | Max. Swale | 26.0 | 0.00 | 3.45 | 3.45 | 2.10 | 9.0 | 0.60 | 4.00 | 1.00 | 3.00 | 1.00 | 9.60 | 0.60 | 4.00 | 2.80 | 7.40 |
| | | Parking One Side (90 Degrees) | Min. Ditch | 26.0 | 0.00 | 3.50 | 3.50 | 5.50 | 12.5 | 0.60 | 1.80 | 1.00 | 3.00 | 1.00 | 7.40 | 0.60 | 1.80 | 3.70 | 6.10 |
| | | | Max. Swale | 30.0 | 0.00 | 3.50 | 3.50 | 5.50 | 12.5 | 0.60 | 4.00 | 1.00 | 3.00 | 1.00 | 9.60 | 0.60 | 4.00 | 3.30 | 7.90 |

| | | | |
|---|--|---|---|
| 3 | | | All Dimensions Shown in Metres, Unless Otherwise Noted |
| 2 | | | |
| 1 | | | |
| Revision Date | | Approved | Title C4 RECREATIONAL ACCESS COLLECTOR STREET SECTION |
|  DISTRICT OF TOFINO | | SUBDIVISION & DEVELOPMENT CONTROL BYLAW | Approved |
| | | | Date November 2011 |
| | | | Drawn By Bunt & Associates |
| | | | DRAWING NUMBER C4 |

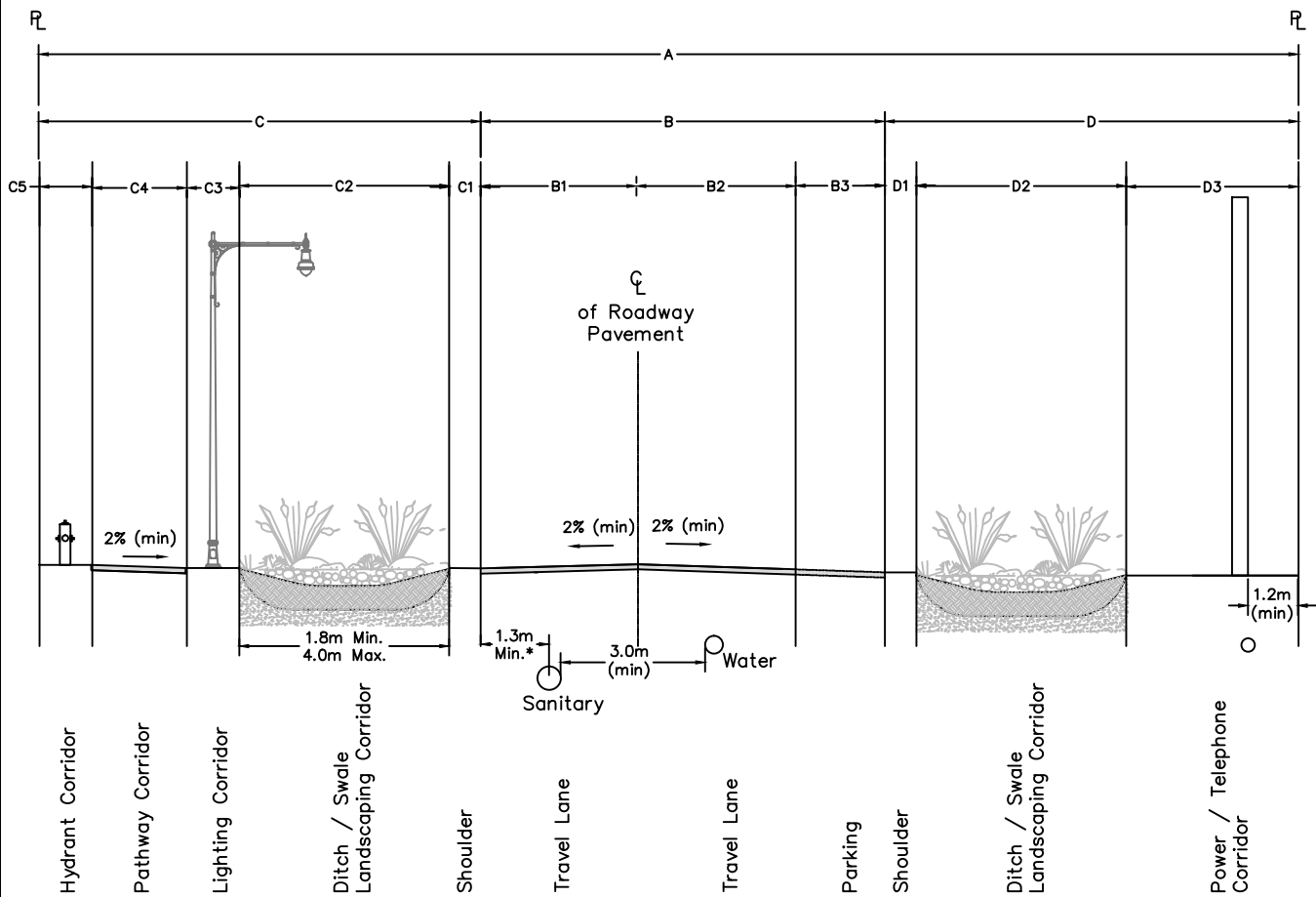

* Minimum dimension from water line to edge of flush curb is 1.3m for cross sections with narrow B dimensions; 2.0m desirable for all other sections

| Code | Name | Parking/ Traffic Operation | Streetlighting & Pedestrian Provision | Drainage | Dimensions | | | | | | | | | | | | | | |
|------|-----------------------------|-------------------------------|--|------------|------------|------|------|------|---------|------|------|------|------|------|---------|------|------|------|---------|
| | | | | | A | B | | | | C | | | | | D | | | | |
| | | | | | | B1 | B2 | B3 | Total B | C1 | C2 | C3 | C4 | C5 | Total C | D1 | D2 | D3 | Total D |
| C5 | Rural Residential Collector | No Parking | bollard lighting of gravel pathway | Min. Ditch | 18.0 | 3.50 | 3.50 | 0.00 | 7.0 | 0.60 | 1.80 | 1.00 | 1.80 | 1.00 | 6.20 | 0.60 | 1.80 | 2.40 | 4.80 |
| | | | | Max. Swale | 22.0 | 3.50 | 3.50 | 0.00 | 7.0 | 0.60 | 4.00 | 1.00 | 1.80 | 1.00 | 8.40 | 0.60 | 4.00 | 2.00 | 6.60 |
| | | Parking One Side | | Min. Ditch | 20.0 | 3.30 | 3.30 | 2.10 | 8.7 | 0.60 | 1.80 | 1.00 | 1.80 | 1.00 | 6.20 | 0.60 | 1.80 | 2.70 | 5.10 |
| | | | | Max. Swale | 24.0 | 3.30 | 3.30 | 2.10 | 8.7 | 0.60 | 4.00 | 1.00 | 1.80 | 1.00 | 8.40 | 0.60 | 4.00 | 2.30 | 6.90 |

All Dimensions Shown in Metres,
Unless Otherwise Noted

Title C5 RESIDENTIAL COLLECTOR
STREET SECTIONS

Revision Date Approved



DISTRICT OF TOFINO

SUBDIVISION & DEVELOPMENT CONTROL BYLAW

Approved

Date

November 2011

Drawn By

Bunt & Associates

DRAWING NUMBER

C5

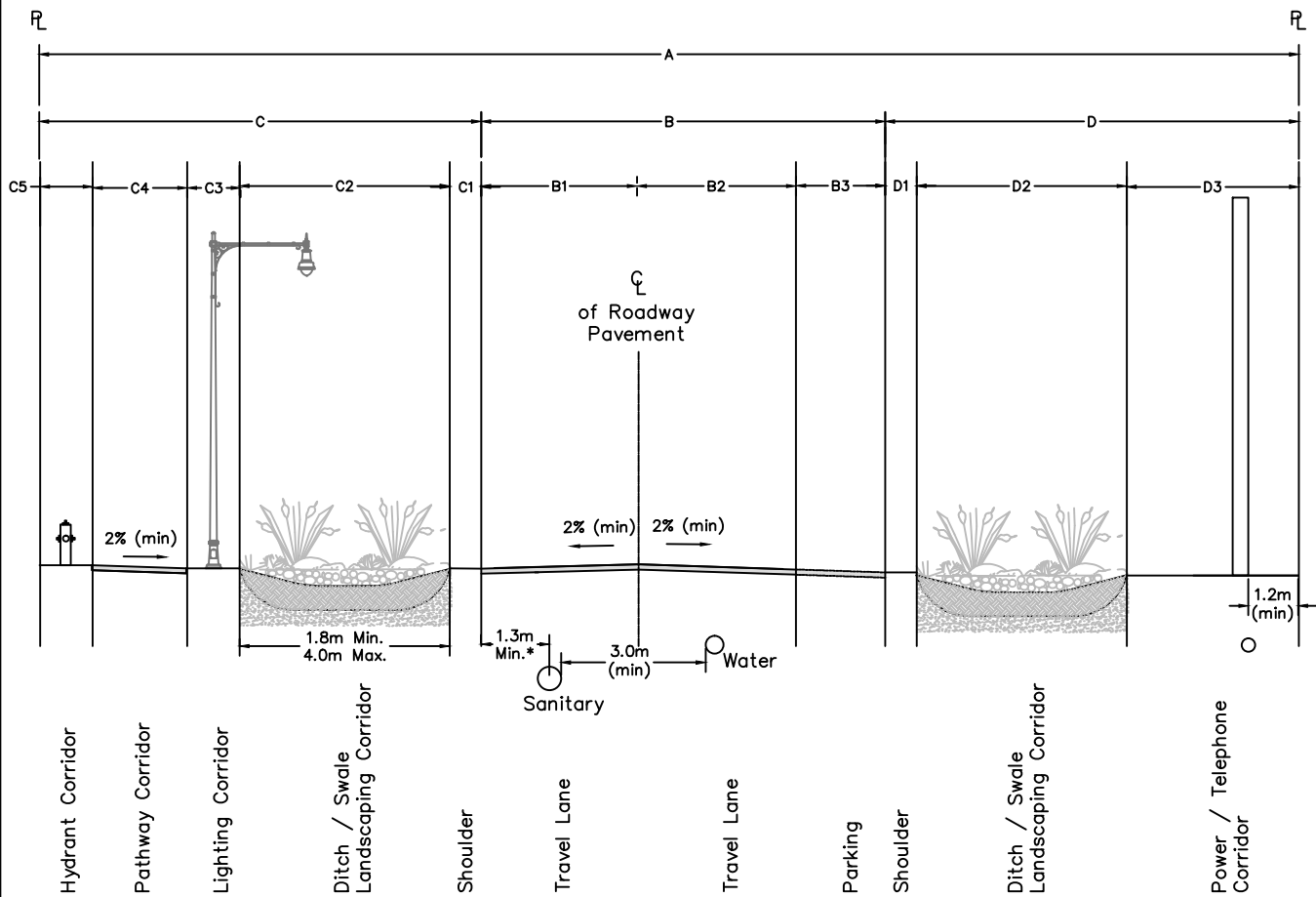

* Minimum dimension from water line to edge of flush curb is 1.3m for cross sections with narrow B dimensions; 2.0m desirable for all other sections

| Code | Name | Parking/ Traffic Operation | Streetlighting & Pedestrian Provision | Drainage | Dimensions | | | | | | | | | | | | | | |
|------|-------------------------|--------------------------------|--|------------|------------|------|------|------|---------|------|------|------|------|------|---------|------|------|------|---------|
| | | | | | A | B | | | | C | | | | | D | | | | |
| | | | | | | B1 | B2 | B3 | Total B | C1 | C2 | C3 | C4 | C5 | Total C | D1 | D2 | D3 | Total D |
| L3 | Rural Residential Local | Parking One Side with Queueing | bollard lighting of gravel pathway | Min. Ditch | 18.0 | 4.30 | | 1.70 | 6.0 | 0.80 | 1.80 | 1.00 | 1.80 | 1.00 | 6.20 | 0.80 | 1.80 | 3.40 | 5.80 |
| | | | | Max. Swale | 22.0 | 4.30 | | 1.70 | 6.0 | 0.80 | 4.00 | 1.00 | 1.80 | 1.00 | 8.40 | 0.80 | 4.00 | 3.00 | 7.80 |
| | | Parking One Side, Two-way Flow | | Min. Ditch | 20.0 | 3.00 | 3.00 | 1.70 | 7.7 | 0.80 | 1.80 | 1.00 | 1.80 | 1.00 | 6.20 | 0.80 | 1.80 | 3.70 | 6.10 |
| | | | | Max. Swale | 24.0 | 3.00 | 3.00 | 1.70 | 7.7 | 0.80 | 4.00 | 1.00 | 1.80 | 1.00 | 8.40 | 0.80 | 4.00 | 3.30 | 7.80 |

All Dimensions Shown in Metres, Unless Otherwise Noted

Title L3 RESIDENTIAL LOCAL STREET SECTION

Revision Date Approved



DISTRICT OF TOFINO

SUBDIVISION & DEVELOPMENT CONTROL BYLAW

Approved
Date November 2011
Drawn By Bunt & Associates

DRAWING NUMBER
L3

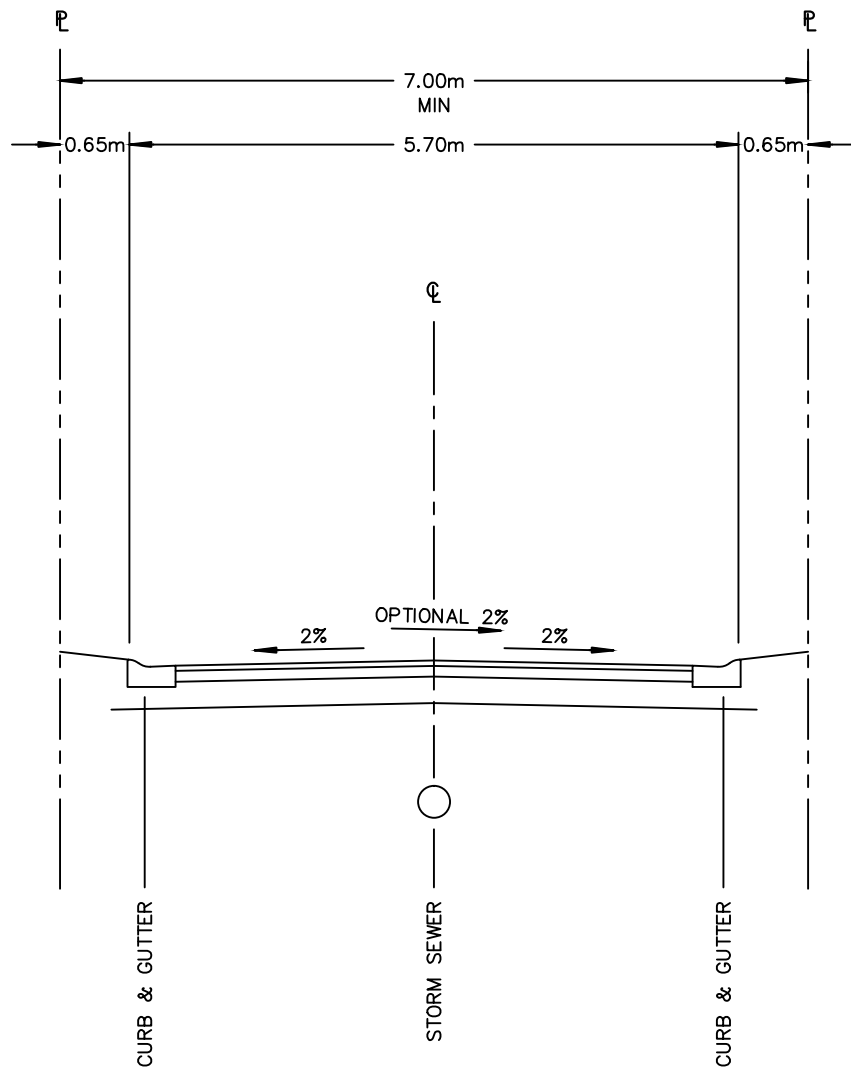

NOTES:

1. PAVED SURFACE – 50mm ASPHALT (COMPACTED THICKNESS)
2. BASE – 100mm CRUSHED GRAVEL (20mm MINUS)
3. SUB-BASE – 250mm PIT RUN GRAVEL (75mm MINUS)
4. MOUNTABLE MONOLITHIC CURB AND GUTTER.
5. DEPTHS OF SURFACING AND BASE GRAVELS ARE MINIMUM AND IN SOME CASES WILL HAVE TO BE INCREASED TO MEET MAXIMUM ALLOWABLE BENKELMAN BEAM DEFLECTION.

| | | | |
|---|---------------|---|--|
| 3 | | All Dimensions Shown in Metres, Unless Otherwise Noted | |
| 2 | | | |
| 1 | | | |
| | Revision Date | Approved | TITLE VILLAGE REAR LANE LOCAL STREET SECTION |
|  DISTRICT OF TOFINO | | SUBDIVISION & DEVELOPMENT CONTROL BYLAW | APPROVED DATE October, 2015 DRAWN BY JEA |
| | | | DRAWING NUMBER L4 |

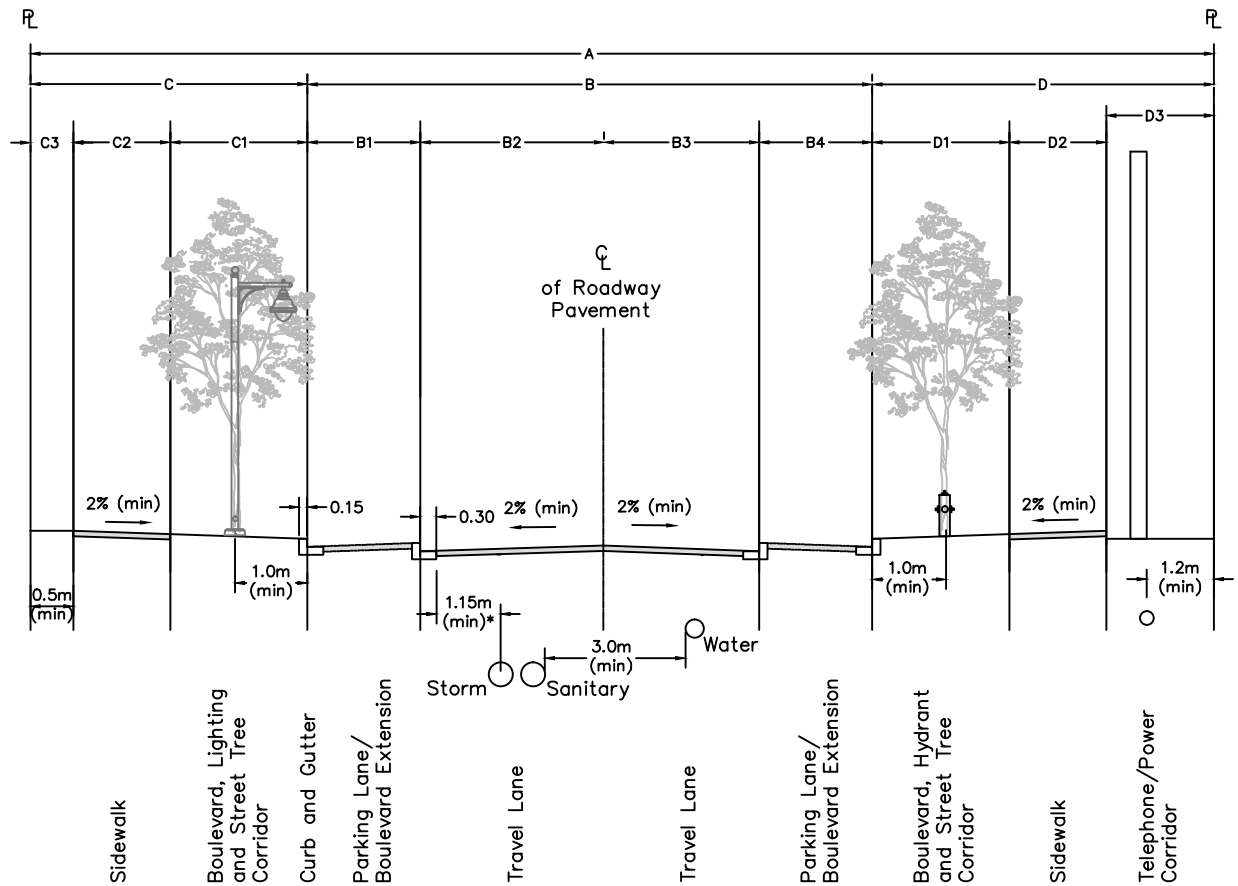

* Minimum dimension from water line to edge of gutter is 1.15m on cross sections with narrow B dimensions; 2.0m is desirable for all other cross sections.

| Code | Name | Parking/ Traffic Operation | Blvd. | Dimensions | | | | | | | | | | | | | |
|------|--|-----------------------------------|-------|------------|------|------|------|-------|---------|------|------|------|---------|------|------|------|---------|
| | | | | A | B | | | | | C | | | | D | | | |
| | | | | | B1 | B2 | B3 | B4 | Total B | C1 | C2 | C3 | Total C | D1 | D2 | D3 | Total D |
| L5.1 | Urban Village Cul-de-sac (>50 m) | Parking One Side with Queueing | Grass | 16.0 | 2.30 | 4.20 | 0.00 | 6.50 | 1.50 | 1.80 | 1.45 | 4.75 | 1.50 | 0.00 | 3.25 | 4.75 | |
| | | | Treed | 18.0 | 2.30 | 4.20 | 0.00 | 6.50 | 2.55 | 1.80 | 0.50 | 4.85 | 2.55 | 0.00 | 2.10 | 4.65 | |
| | | Parking One Side, Two-way Flow | Grass | 16.0 | 2.00 | 3.00 | 3.00 | 0.00 | 8.00 | 1.50 | 1.80 | 0.70 | 4.00 | 1.50 | 0.00 | 2.40 | 4.00 |
| | | | Treed | 18.0 | 2.00 | 3.00 | 3.00 | 0.00 | 8.00 | 2.65 | 1.80 | 0.55 | 5.00 | 2.65 | 0.00 | 2.35 | 5.00 |
| | Parking Both Sides | Grass | 18.0 | 2.00 | 3.00 | 3.00 | 2.00 | 10.00 | 1.50 | 1.80 | 0.70 | 4.00 | 1.50 | 0.00 | 2.50 | 4.00 | |
| | | Treed | 20.0 | 2.00 | 3.00 | 3.00 | 2.00 | 10.00 | 2.65 | 1.80 | 0.55 | 5.00 | 2.65 | 0.00 | 2.35 | 5.00 | |
| L5.2 | Urban Village Cul-de-sac (<50 m) | Parking One Side with Queueing | Grass | 15.0 | 2.30 | 4.20 | 0.00 | 6.50 | 1.90 | 0.00 | 1.45 | 3.35 | 1.90 | 0.00 | 3.25 | 5.15 | |
| | | | Treed | 15.0 | 2.30 | 4.20 | 0.00 | 6.50 | 2.65 | 0.00 | 1.10 | 3.75 | 2.65 | 0.00 | 2.10 | 4.75 | |
| | | Parking One Side, Two-way Flow | Grass | 15.0 | 2.00 | 3.00 | 3.00 | 0.00 | 8.00 | 1.50 | 0.00 | 1.50 | 3.00 | 1.50 | 0.00 | 2.00 | 4.00 |
| | | | Treed | 16.0 | 2.00 | 3.00 | 3.00 | 0.00 | 8.00 | 2.55 | 0.00 | 0.90 | 3.45 | 2.55 | 0.00 | 2.00 | 4.55 |

All Dimensions Shown in Metres,
Unless Otherwise Noted

Title L5 CUL-DE-SAC LOCAL
STREET SECTION

Revision Date Approved



**DISTRICT
OF TOFINO**

SUBDIVISION &
DEVELOPMENT
CONTROL BYLAW

Approved

Date

November 2011

Drawn By

Bunt & Associates

DRAWING NUMBER

L5

Schedule 'B' - District of Tofino - Approved Products List
Subdivision and Development Control Bylaw No. 1201, 2014

| Division | Item | Type | Size | Standards | Approved Products | Comments | Date Approved |
|------------|--|---|--|--|---|--|---------------|
| Waterworks | Fire Hydrants | Compression with lugs for tie rods | 150mm inlet | AWWA C502-94 (143.75mm outside dia 4 threads per 25mm) | Terminal City C71P AVK #2780 | Paint Red with white port caps- contact Fire Department for thread sizes and diameters - counter clockwise opening | 10-Nov-15 |
| Waterworks | Pipe | PVC | 75mm to 300mm DR25/18/14 Class 100/150 | AWWA C900/C905 CSA 137.3 | IPEX or J-M "Blue Brut" (100mm to 1200mm) Royal Pipe Systems (100mm to 450mm) Rehau Aqualoc Northern Pipe (100mm to 762mm) | | 10-Nov-15 |
| Waterworks | Tracer Wire | RWU 90 | 10 Gauge (AWG) | | | XLPE insulation for direct burial applications | 10-Nov-15 |
| Waterworks | Pipe | Ductile Iron | | AWWA C151 | | | 10-Nov-15 |
| Waterworks | Pipe | Steel | | AWWA C200 | | | 10-Nov-15 |
| Waterworks | Service Connection Pipe | HDPE C/W tracer wire laid in trench | 19mm to 50mm | AWWA C901-22, pressure class 160, 200 CSA B137.1 | | Tracer wire laid in trench, must be visible in meter and BFP box | 10-Nov-15 |
| Waterworks | Pipe fittings: 90, 45, 22.5, crosses, tees, wyes, reducers | Cast Iron Ductile Iron Compact Ductile Iron | to 1035 Kpa to 2415 Kpa to 2415 Kpa | AWWA C110 AWWA C110 AWWA C153 | Must be stamped with AWWA standards | | 10-Nov-15 |
| Waterworks | Pipe Joint Protection | | As Required | | Canus "JointWrap" cold applied pipe joint sleeve or equal | | 10-Nov-15 |
| Waterworks | Corporation Stops | Compression Type | 19mm to 50mm | AWWA C800 1035 Kpa | Mueller H-15008 Ford F-1000 Cambridge E-17072, series 102 | to 75mm with Superintendent of Road Works approval only | 10-Nov-15 |
| Waterworks | Curb Stops | | 19mm to 50mm | ASTM B62 Full flow, full port | Mueller H-110 Ford BH44-233 Cambridge series 103 | | 10-Nov-15 |
| Waterworks | Service Saddles | Ductile Iron Pipe | Service to 75mm Double strap | AWWA C800, C210, C213, C111 | Robar 2408DS Canpac CD-2 Robar 2506DS Canpac CDES-2 | | 10-Nov-15 |
| Waterworks | Pipe | HDPE | 100mm to 300mm | PE 4710, PE3408, C906-12 | Sclair - KWH | | 10-Nov-15 |

| Division | Item | Type | Size | Standards | Approved Products | Comments | Date Approved |
|------------|------------------------------|--|--|--|--|---|---------------|
| Waterworks | Service Saddles | PVC Pipe | Service to 75mm Double strap | AWWA C800, C210, C213, C111 ASTM (A536) | Robar 2406DS, 27-6DS, 2506DS, 2606DB Smith-Blair 317, 357 Canpac SC-1, SC-2 | | 10-Nov-15 |
| Waterworks | Abandon Service Sleeves | | 150mm to 600mm Mains and 19mm or 25mm Services | NCT 304 SS Const. | Robar 6636 AS | | 10-Nov-15 |
| Waterworks | Tapping Sleeves | Ductile/PVC Pipe | 75mm and larger | AWWA C900 ASTM (A283) | Robar 6606, 6906, 6506 Romac SST, FTS Smith-Blair 622, 662 | | 10-Nov-15 |
| Waterworks | Repair Clamps | Double bolted with or without tapped outlets | 100 to 350mm dia 200 to 600mm lengths | Gasket to ASTM D2000 | Robar 5626 Canpac Style CR2 | | 10-Nov-15 |
| Waterworks | Couplings | | | AWWA C219, C213, C210, C550, ASTM (A536) Gaskets ASTM D2000 endplates ASTM A536 centre ring ASTM A536 bolts/nuts AWWA C111 | Robar 1408, 1506 Robar 1726 Multi Range Hymax 2000 Romac Macro HP Smith-Blair #441 | | 10-Nov-15 |
| Waterworks | Flanged Coupling Adapters | | | AWWA C219, C213, C210, C550, ASTM (A536) Gaskets ASTM D2000 endplates ASTM A536 centre ring ASTM A536 bolts/nuts AWWA C111 | Robar 7404 Romac FCA 501 Smith-Blair #912 | | 10-Nov-15 |
| Waterworks | Restrainers | Ductile PVC PVC (bell joint) | 100mm to 300mm | AWWA C219, C210, C213, C550 C900 DR 18 | Uni Flange series 1300 (PVC) Uni Flange 1350,1390 (PVC) Uni Flange 1400 (DI) Robar 4400 Robar 4450, 4452 EBAA IRON Series 3800 EBAA IRON 1506TD Royal Pipe Cobra Lock | | 10-Nov-15 |
| Waterworks | Gate Valves | Resilient seated | 100mm to 300mm | AWWA C509 | Clow F-6100 Mueller A-2370 AVK 03, 25/45 | Counterclockwise-confirm with Superintendent | 10-Nov-15 |
| Waterworks | Butterfly Valves | | | AWWA C504 class 150B | As per contract drawings | | 10-Nov-15 |
| Waterworks | Valve Boxes | Mainline | Circular | | Terminal City "Maple Ridge" MR Victoria Foundary "Robar" | Use TC "NT" in non-paved areas | 10-Nov-15 |

| Division | Item | Type | Size | Standards | Approved Products | Comments | Date Approved |
|------------|-------------------------|---------------------------------|-------------------|--|--|---|---------------|
| Waterworks | Service Boxes | Curb Stop | Circular | | Terminal City "NCR" Alf's Flat Tops | | 10-Nov-15 |
| Waterworks | Vaults | Pressure Reducing Valve Chamber | | As per specifications | Lombard Precast Hyland Precast AE Concrete | | 10-Nov-15 |
| Waterworks | Water Meter | | 19mm and 25mm | | Elster SM700 | Itron 60w ERT prewired to meter Pit style must use lid mount pit antennae and compatible lid. | 10-Nov-15 |
| Waterworks | Water Meter | | Larger than 75 mm | | Aquamaster | Itron 60w ERT prewired to meter | 10-Nov-15 |
| Waterworks | Water Meter | | Up to 75mm | | Aquamaster | Itron 60w ERT prewired to meter | 10-Nov-15 |
| Waterworks | Setter Idler | Brass or Cambridge P/N | 15mm to 25mm | | 450 Series (1-4) | | 10-Nov-15 |
| Waterworks | Setter Idler | Cambridge | 38mm to 50mm | | 450 Series (5-6) | | 10-Nov-15 |
| Waterworks | Setter | Coppersetter | 15.625 to 25mm | NSF-61 | Mueller Ford Cambridge Brass | Full Flow - Dual Check with relief screw | 10-Nov-15 |
| Waterworks | Meter Boxes | Concrete (Brooks Box) | | H-20 Loading | A.E. Concrete | Full perimeter recess | 10-Nov-15 |
| Waterworks | Meter Box Lid | Cast Iron (Brooks Box) | | H-20 Loading | Terminal City | Solid Lid Stamped with Water Meter No Recess for radio read. | 10-Nov-15 |
| Waterworks | Service Stub Restrainer | Stainless Steel | | | Robar | Capping bracket for covering a corp stop at the main in an AC concrete pipe - When abandoning service | 10-Nov-15 |
| Sanitary | Pipe | PVC smooth | 100mm to 475mm | ASTM D3034 CSA.B182.2, 100, 150mm DR28, 200mm DR35 | Royal Pipe Systems Ipex or J-M "Ring-Tite" Rahau Abondloc Northern Pipe | | 10-Nov-15 |

| Division | Item | Type | Size | Standards | Approved Products | Comments | Date Approved |
|----------|--------------------------------------|----------------------------|----------------|--|--|---|---------------|
| Sanitary | Pipe | PVC smooth | 200mm to 375mm | ASTM D3034, CSA 182.2 100, 150mm DR 28 > 200mm DR 35 | Royal Pipe Systems Iplex "Ring-Tite" Rauhau Abondloc Northern Pipe J-M Manufacturing | | 10-Nov-15 |
| Sanitary | Pipe | Ribbed extruded seamless | 450mm to 900mm | CSA B182.4 ASTM F794-89, D2412 | Kor Flo (450mm – 900mm) Iplex "Ultra-Rib" (450mm-600mm) Rahau ARauRib (375mm-450mm) | | 10-Nov-15 |
| Sanitary | Pipe Connectors | Rubber Couplings | | Stamped CSA Approved | | | 10-Nov-15 |
| Sanitary | Tees | Inserta Tee | 100mm to 300mm | MMCD 33 30 01 pg 8 - 3.10.1 Detail dwg S7 | Royal Pipe Systems Galaxy Plastics Ltd. "EZ Tee" | Post-main construction only - Inserta tees will not be permitted for new construction. Maximum service size to be at least 2 pipe sizes less than main. | 10-Nov-15 |
| Sanitary | Pipe Fittings: Wyes, bends, reducers | PVC smooth | | CSA B182.2 182.2 ASTM D3034 | | | 10-Nov-15 |
| Sanitary | Pipe Fittings: Wyes, bends, reducers | PVC smooth | 200mm to 375mm | ASTM D3034, CSA 182.2 100, 150mm DR 28 > 200mm DR 35 | | | 10-Nov-15 |
| Sanitary | Inspection Chambers | Add A Flap Adapt A Valve | 100mm to 150mm | MMCD 33 30 01 pg 8 - 3.10.3 | Royal Pipe Systems Pro-Line Fittings | c/w red (colour coded) lid | 10-Nov-15 |
| Sanitary | Manhole | Frame and Cover | | H20 Loading ASTM A48 | Terminal City Westview Sales | | 10-Nov-15 |
| Sanitary | Manholes | Adjustable Frame and Cover | C-18 | H20 Loading | Terminal City Westview Sales | Must use never-seize and protective covering on adjustable bolts | 10-Nov-15 |
| Sanitary | Manhole | Pre cast sections | | ASTM C478M As per manhole specifications | Lombard Precast Hyland Precast Langley Precast | | 10-Nov-15 |
| Sanitary | Manhole Base | Pre Bench | | ASTM C478M As per manhole specifications | Lombard Precast Hyland Precast Langley Precast | | 10-Nov-15 |
| Sanitary | Manholes | Adjusting Rings | | HDPE - H20 Loading | Iplex Life Saver Manhole Adjusting Rings | Must use SIKAFLEX adhesive | 10-Nov-15 |

| Division | Item | Type | Size | Standards | Approved Products | Comments | Date Approved |
|----------|--------------------------------------|------------------------------|-----------------|--|---|--|---------------|
| Sanitary | Gate Valves | | | | AVK | Iron body, resilient seated, stainless steel stem, 50 mm operating nut | 10-Nov-15 |
| Sanitary | Ball Check Valve | | | | AVK Series 53/3x | Iron body, resilient seated, ball check | 10-Nov-15 |
| Storm | Pipe | Concrete | <675mm | Non-reinforced circular concrete pipe and fittings to ASTM C14M designed for flexible rubber gasket joints to ASTM C443M | Lombard Precast Hyland Precast Langley Precast | | 10-Nov-15 |
| Storm | Pipe | Concrete | >675mm | Reinforced circular concrete pipe and fittings to ASTM C76M designed for flexible rubber gasket joints to ASTM C443M | Lombard Precast Hyland Precast Langley Precast | | 10-Nov-15 |
| Storm | Pipe | PVC smooth | 200mm to 375mm | ASTM D3034, CSA 182.2 100, 150mm DR 28 > 200mm DR 35 | Royal Pipe Systems Ipex "Ring-Tite" Rauhau Abondloc Northern Pipe J-M Manufacturing | | 10-Nov-15 |
| Storm | Pipe | PVC ribbed diagonal | 750mm and 900mm | CSA B182.4 ASTM F794 Class 5, ASTM D2412 | Ipex "Perma-Loc" Royal Pipe Systems | | 10-Nov-15 |
| Storm | Pipe | PVC ribbed extruded seamless | 200mm to 900mm | CSA B182.4 ASTM F794-89, D2412 | Kor Flo 450mm-900mm) Ipex Ultra-Rib (450mm-600mm) Rehau ArauRib (450mm) | | 10-Nov-15 |
| Storm | Pipe | Corrugated steel pipe | >900mm | CSA G401-93 | | | 10-Nov-15 |
| Storm | Culverts | Corrugated steel pipe HDPE | >=300mm | CAN G401 CSA B 182.8 | Boss 2000 Armtec | | 10-Nov-15 |
| Storm | Tees | Inserta Tee | 100m to 300mm | MMCD 33 40 01 pg 9 - 3.10.1 Detail dwg S8 | Royal Pipe Systems Galaxy Plastics Ltd. "EZ Tee" | Maximum service size to be at least 2 pipe sizes less than main. | 10-Nov-15 |
| Storm | Pipe Fittings: Wyes, bends, reducers | PVC smooth | | CSA B182.1 182.2 ASTM D3034 | Royal Pipe Systems Ipex | | 10-Nov-15 |
| Storm | Pipe Fittings: Wyes, bends, reducers | PVC rib to ribbed | 375mm plus | ASTM F794 CSA B182.4 | Royal Pipe Systems Ipex | | 10-Nov-15 |

| Division | Item | Type | Size | Standards | Approved Products | Comments | Date Approved |
|----------|-------------------------------------|---|------------------------------|---|---|--|---------------|
| Storm | Inspection Chambers | Add A Flap Adapt A Valve | 150mm | MMCD 33 40 01 pg 9 - 3.10.3 | Royal Pipe Systems Pro-Line Fittings | | 10-Nov-15 |
| Storm | Manhole | Frame and Cover | | H20 Loading | Terminal City | | 10-Nov-15 |
| Storm | Manholes | Adjustable Frame and Cover | C-18 | H20 Loading | Terminal City Westview Sales | Must use never-seize and protective covering on adjustable bolts | 10-Nov-15 |
| Storm | Manholes | Precast sections | | ASTM C478M As per manhole specifications | Lombard Precast Hyland Precast Langley Precast | | 10-Nov-15 |
| Storm | Manholes | Adjusting Rings | | HDPE - H20 Loading | Ipex Life saver Manhole Adjusting Rings | Must use SIKAFLEX adhesive | 10-Nov-15 |
| Storm | Manhole Base | Pre Bench | | ASTM C478 | Lombard Precast Hyland Precast Langley Precast | | 10-Nov-15 |
| Storm | Catchbasin | Frame and Grate | Rectangular | ASTM A48 H20 Loading | Terminal City Westview Sales | | 10-Nov-15 |
| Storm | Catchbasin | With curb inlet | Rectangular | ASTM A48 H20 Loading | Terminal City Westview Sales | | 10-Nov-15 |
| Storm | Catchbasin | Precast concrete | | ASTM C478M, leads 200mm dia, DR35 | | As per Standard Detail Drawings | 10-Nov-15 |
| Storm | Catchbasin | Adjusting Rings | | HDPE - H20 Loading | Ipex Life Saver Manhole Adjusting Rings | Must use SIKAFLEX adhesive | 10-Nov-15 |
| Storm | Headwall | Premanufactured (Concrete or Composite) | Pipe size of 200mm to 1200mm | | Custom Industrial Fibreglass Ltd. PRO-ECO-LITE Lombard Pre Cast Inc. | Provide grates on all storm drain inlets and outlets over 375mm or over 300mm. | 10-Nov-15 |
| Storm | Manufactured Oil/Sediment Trap Unit | In Precast Manhole | | Lid and Manholes H20 Loading | Stormceptor Contech Vortechs VortSentry | Size in accordance with specifications | 10-Nov-15 |

| Division | Item | Type | Size | Standards | Approved Products | Comments | Date Approved |
|-----------------|---|------------------------------|----------------|---|--|--|---------------|
| Storm | Open Drain | PVC | 100mm to 200mm | | NDS Pro Series | PVC grate in Blvd application H-20 loading grate in road application | 10-Nov-15 |
| Street Lighting | | | | As per MMCD | As per MMCD | | 10-Nov-15 |
| Signs | Round Post Break-out Coupler and Anchor Extension (Break Away Base) | To fit Galvanized Round Pole | 50mm | 12G | Inprotect - Anchor adapter part # HDAAA and complete top part # BOR 238-1316 Or Break-out 2-3/8" round post coupler – complete part # BOR 238-1012 | To be used when pole is to be placed in a finished concrete or asphalt surface | 10-Nov-15 |
| Signs | Post Mounting Hardware | Round | 50mm | HS-1 | | | 10-Nov-15 |
| Signs | Stop Sign Blades | | | | 600mm x 600 mm stop signs for local roads. 750mm x 750mm stop signs for arterial and collector roads | All stop signs to be Diamond Grade | 10-Nov-15 |
| Signs | All Other Sign Blades | | | All signs to conform to BC Min of Transportation and/or TAC | | | 10-Nov-15 |
| Landscaping | Retaining Walls | Lock + Load | | | A.E. Concrete Precast Products | | 10-Nov-15 |
| Landscaping | Retaining Walls | Allen Block | | | Allan Block Corp. | | 10-Nov-15 |

Schedule 'C' - MMCD - Design Guideline Manual – 2014 Edition (Bound Separately)

Subdivision and Development Control Bylaw No. 1201, 2014

THIS PAGE IS INTENTIONALLY LEFT BLANK

Schedule 'D' - MMCD - Volume II Platinum Edition (Bound Separately)

Subdivision and Development Control Bylaw No. 1201, 2014

THIS PAGE IS INTENTIONALLY LEFT BLANK

1. GENERAL DESIGN CONSIDERATIONS AND DRAFTING STANDARDS

1.1. INDEPENDENT UTILITIES

Subdivision design to include coordination of Independent Utility design for works within the roads and/or municipal rights of way as required to service the lots created. The Developer, or his Authorized Agent, shall ensure that the design of those works is integrated with the design of other works required under this bylaw. These Independent Utilities shall include, but may not be limited to the following:

- BC Hydro electrical power distribution;
- Telus telephone and communications; and,
- Shaw Cable communications.

Independent Utilities to be carried in an underground duct system.

1.2 UTILITY RIGHTS-OF-WAY

The Developer is responsible to provide all rights-of-way required for construction of both municipal and independent utilities required to service the lots created. This requirement is not limited to the subject parcels and may include rights-of-way across neighbouring properties.

2.1 SCOPE

This section shall govern the preparation of engineering drawings associated with development approval and the Municipal works and services.

2.2 GENERAL REQUIREMENTS

A complete set of construction drawings shall consist of separate drawings of some or all of the following:

- (a) Site plan and key plan
- (b) Drainage area plan
- (c) Plan and profile for roads, drainage and storm sewers
- (d) Plan and profile for sanitary sewers and watermains
- (e) Plan and profile for sanitary and storm sewers for common trench designs
- (f) Plans of proposed street lighting, hydro, telephone and cablevision

- (g) Additional plans showing any special details and cross-sections
- (h) Landscaping plans as required by Tofino

- 2.2.1 Maximum drawing size shall be 610 mm x 915 mm (24" x 36").
- 2.2.2 Drawings shall be prepared by utilizing computer drafting methods. The MMCD drawing template shall be utilized.
- 2.2.3 Drawing scales and dimensions shall be shown. To facilitate scaling, graphical scales shall be indicated on all reproducible drawings. All drawings shall be metric.
- 2.2.4 In all cases, lettering shall be done with sufficient care to permit clear, one-half size reduction.
- 2.2.5 The drawings shall be neat and legible and they shall clearly locate and describe the work in sufficient detail to facilitate construction, with clearly defined limits of construction.
- 2.2.6 Plan profile drawings shall be drawn with the profile on the bottom of the drawing sheet.
- 2.2.7 Standard drafting procedures shall be used for dimensioning, arrowheads, line densities, etc. Lettering shall be to Leroy metric heights and widths with the minimum height of lettering being 2 mm to 2.5 mm. Vertical upper case lettering is preferred. Conflicts between line work, symbols, dimensions or text shall be removed.
- 2.2.8 All elevations shown on drawings shall be metric geodetic datum NAD 83 and the source and location of datum shall be clearly noted on each drawing.
- 2.2.9 Drawing title block shall include the project name, project location, type of drawing (i.e. Site Plan) and Engineer's name and/or company name and logo, address, phone number and email address.
- 2.2.10 Plan and Profile drawings shall be to the following scales unless otherwise approved:

| | |
|------------|----------------|
| Horizontal | 1:500 or 1:250 |
| Vertical | 1:50 |
- 2.2.11 The following notes shall be shown on either the site plan or the first drawing of the set:
 - (a) "All work and materials are to be as described in the District of Tofino 'Design Guidelines and Specifications,' or as otherwise approved by the Superintendent."
 - (b) "Connection to, or alteration of, existing District-owned utilities, will be undertaken by District of Tofino forces only, unless otherwise authorized by the Superintendent."

- (c) "A 'Construction Permit to Install Works Within Streets, Lanes and Tofino Property Areas', will be required where construction is to be undertaken in District of Tofino rights-of-way and/or on District of Tofino-owned utilities or properties."
 - (d) "Upon approval of the permit, the Superintendent shall be notified forty-eight (48) hours prior to commencement of work."
- 2.2.12 Standard details such as manholes, catch basins, hydrants, etc., that are shown and described in the District of Tofino Standard Detailed Drawings need not be shown in detail on the drawings. Standard symbols for the various facilities as shown on Standard Drawings detailing Standard Symbols and Abbreviations shall be used and shown in a legend on all drawings.
- 2.2.13 All drawings shall bear the date stamp/seal and signature of the professional engineer responsible for the design.
- 2.2.14 Provision shall be made on all drawings for the insertion of the District of Tofino as-built file number in the lower right-hand corner of the drawing sheet. The space provided shall be a minimum ten (10) mm high by fifty (50) mm long.
- 2.2.15 Numerical values shown on the construction drawings shall reflect the decimal precision of the numbers. Generally numbers shall be shown to two (2) decimals unless accuracy warrants otherwise.
- 2.2.16 All elevations shown on drawings shall be metric geodetic datum. The source and location shall be clearly noted on each drawing.
- 2.2.17 All digital drawings submitted to the District must be in either DXF or DWG format, and the site shall be located on NAD83 (CSRS) coordinates.

2.3 SITE PLAN AND KEY PLAN

- 2.3.1 The Site Plan of the construction works shall be to a scale of not less than 1:1000.
- 2.3.2 The following existing and proposed information shall be shown on the Site Plan:
- (a) Existing watercourses and setbacks
 - (b) Pavement, curbs
 - (c) Ditches, culverts, storm sewers, manhole cleanouts, inlet/outlet structures and catch basins
 - (d) Sanitary sewers, manholes, cleanouts
 - (e) Watermains, valves, hydrants, prvs, air valves, flush outs
 - (f) All pertinent property, right-of-way and easement lines
 - (g) Road allowance and easement dimensions

- (h) Lot numbers and existing legal plan numbers and addresses where applicable
 - (i) One-metre contour lines
 - (j) Plan and profile drawing reference numbers
 - (k) Underground hydro, telephone, streetlights and cable and their related appurtenances
 - (l) Survey control monuments
 - (m) Traffic control devices, poles, conduits, signs and painting
 - (n) Routing of all major storm flows including the 100 year storm
 - (o) Approved street name from the District
- 2.3.3 A Key Plan to a small scale (e.g. 1:10,000), showing the location of the works in relation to major streets, shall be provided in the upper right-hand section of the drawing sheet.
- 2.3.4 A drawing index shall be provided and include the drawing titles, drawing numbers and provision for the District of Tofino as-built field number.

2.4 DRAINAGE AREA PLAN

- 2.4.1 A drainage area plan (with a 1:500 to 1:2500 scale) must accompany storm drainage calculations for a subdivision or development. The plan shall include the following information:
- (a) Onsite and offsite drainage areas
 - (b) Existing and proposed drainage systems
 - (c) The 100 year storm flood routing
 - (d) Contours
 - (e) Existing and proposed road and lot layout
 - (f) Existing and proposed drainage areas
 - (g) Separate coloured existing and proposed drainage area plans where required for clarity

2.5 SITE AND LOT GRADING PLAN

- 2.5.1 The Superintendent may require site and lot grading plans in areas where driveway grades, drainage outlets, servicing elevations, etc. may have a critical impact on the development of the lot.

- 2.5.2 The scale shall be 1:500 or 1:250.
- 2.5.3 The plans shall include the following information:
- (a) Existing ground elevations of lot corners and proposed building site. Include the location and depth of any fill areas.
 - (b) Location and invert elevations for storm and sanitary services
 - (c) Location of water service
 - (d) Minimum building elevation (MBE) and critical finished landscape elevations
 - (e) Direction of surface drainage and location of drainage swales, ditches and catch basins
 - (f) Proposed driveway locations and grades
 - (g) Applicable information required under MMCD Design Guidelines Manual – Storm Drainage

2.6 PLAN AND PROFILE DRAWINGS – GENERAL

Each base plan and profile shall show, but not be limited to, the following information:

- 2.6.1 All cadastral information including property, right of way and easement lines and dimensions in sufficient detail to relate design to surrounding and adjacent properties
- 2.6.2 Legal description of properties
- 2.6.3 Road allowance dimensions
- 2.6.4 Existing pavement, curbs, sidewalks, ditches, driveways, lanes, retaining walls, buildings, trees and shrubs, etc., within right-of-way, and beyond the rights of way as required
- 2.6.5 Street addresses of existing buildings
- 2.6.6 Approved street name from District
- 2.6.7 Existing underground and surface utilities and services with offsets including, but not limited to, the following:
- (a) Sanitary sewers, storm sewers, watermains and appurtenances
 - (b) Street light poles, conduit and appurtenances
 - (c) B.C. Hydro poles and underground wiring ducts and appurtenances

- (d) Telus poles and underground wiring ducts and appurtenances
 - (e) Cablevision ducts and appurtenances
 - (f) Traffic control devices, conduits, signs and painting
- 2.6.8 All relevant topographic information including one (1) metre contour lines. Provide spot elevations and closer intervals on flat ground.
- 2.6.9 Plan and profile drawing reference number.
- 2.6.10 Benchmark elevation, identification number and location shall be shown in the notes section of each drawing.
- 2.6.11 Right-of-way and/or road centerline stationing to metric standards (0+000) at 20-metre intervals and shall be related geometrically to legal property lines or survey monuments.
- 2.6.12 Where possible, plan views shall be horizontal across the drawing sheet and shall be aligned vertically by centre-line stationing with the profile view.

2.7 ROADS

The following shall be shown in addition to the information required in section 2.6:

- 2.7.1 All proposed roadworks, complete with existing elevation tie-in points and offsets from road centerline, including: pavement, curbs, sidewalks and poles.
- 2.7.2 All proposed roadworks including pavement, curbs, sidewalks, traffic control devices, poles, signs and painting, complete with offsets from road centre line.
- 2.7.3 Stations of the BC and EC of road centerline and curb return horizontal curbs together with the curve information including delta angle, centerline radius, tangent length and centerline arc length.
- 2.7.4 Details of intersections with spot elevations at all critical points including grades and elevations of curb returns.
- 2.7.5 Catch basin rim elevations and stations related to road centerline chainage.
- 2.7.6 Existing ground profile and finished pavement profile along the pavement centerline with elevations at 10 metre intervals. Existing ground profile to extend minimum 50 m beyond the end of the proposed work unless otherwise approved by the Superintendent.
- 2.7.7 Cross fall or crown information with gutter elevations at change points.
- 2.7.8 Proposed road centerline grade.
- 2.7.9 Stations and elevations of BVC, EVC and VPI.
- 2.7.10 Vertical curve information including the length of curve and sag or crest K value, where K equals the length of the vertical curve in metres divided by the algebraic difference in grades, percent.

- 2.7.11 Elevations along the vertical curve at ten (10) metre intervals.
- 2.7.12 Elevation and station of low and high spots of vertical curves.
- 2.7.13 Where the slope of existing ground is greater than 10% across the right-of-way, cross-sections shall be shown at intervals not exceeding twenty (20) metres (where required by the Superintendent).
- 2.7.14 Typical road cross-section showing right-of-way, pavement width, sidewalks, curbs, underground utilities, hydro, power and street light poles, hydrants and their related offsets.
- 2.7.15 Proposed monument locations.
- 2.7.16 Additional design details as required.

2.8 STORM AND SANITARY SEWERS

The following shall be shown in addition to the information required in section 2.6:

- 2.8.1 All proposed storm and sanitary works including manholes, drop pipes, cleanouts, catch basins, inlet/outlet structures, pipe work, ditches, culverts and wyes, and pipe inverts.
- 2.8.2 Existing ground profile and finished ground or pavement profile along the centerline of the proposed sewer.
- 2.8.3 Distance between manholes with proposed grade.
- 2.8.4 Stations and elevations of the BC and EC of all horizontal curves with the curve information including delta angle, radius, tangent length and arc length.
- 2.8.5 Stations and elevations of BVC, EVC and VPI.
- 2.8.6 Vertical curve information including the length of vertical and maximum pipe deflection.
- 2.8.7 Elevations along vertical curves at ten (10) metre intervals.
- 2.8.8 Size, type and class of pipe.
- 2.8.9 Existing or proposed pipe crossings to be shown in profile.
- 2.8.10 Proposed inverts and offset locations to property line of service connections at property lines.
- 2.8.11 Location of existing buildings on properties served by storm and sanitary sewers.
- 2.8.12 Invert of existing sanitary and storm outlets at existing buildings.
- 2.8.13 Elevation of existing ground at the lowest point on the proposed lot.

2.8.14 Routing of all major storm flows including the 100 year storm with minimum basement floor elevations provided for properties with the potential to be affected by the major storm flows.

2.8.15 Additional design details as required.

2.9 WATERWORKS

The following shall be shown in addition to the information in section 2.6:

2.9.1 All proposed waterworks including size, type and class of pipe, hydrants, valves, fittings and all related appurtenances with offsets related to road centerline.

2.9.2 Locations of proposed service connections including an offset distance from an iron pin or lot corner.

2.9.3 Existing ground profile and finished ground or pavement profile, and invert profile along the centerline of the proposed watermain.

2.9.4 All service crossings to be shown in profile (e.g., sewer mains, water mains, storm mains, etc.)

2.9.5 Extent of work required in making the connection to existing watermains.

2.9.6 If the proposed watermain alignment or profile varies from the road centerline, the following shall be provided:

(a) Stations of the BC and EC of horizontal curves together with curve information including delta angle, radius, tangent length and arc length.

(b) Stations and elevations of the BVC, EVC and VPI of vertical curves together with curve information including curve length and maximum pipe deflection required.

(c) Elevations along vertical curves at ten (10) metre intervals.

(d) Proposed grades.

2.9.7 Additional design details as required.

2.10 STREET LIGHTING, B.C. HYDRO, TELUS

The following information shall be shown in addition to the information required for the plan view in Section 2.6:

- 2.10.1 Pole, conduit and appurtenances locations with offsets related to road centerline.
- 2.10.2 Size, type, class of conduits.
- 2.10.3 Schematics of wiring details for street lights and traffic signals.
- 2.10.4 The plan shall be to a scale of 1:500 or 1:250.

2.11 DETAIL SHEET AND CROSS-SECTIONS

- 2.11.1 Where there is not sufficient room on the plan and profile drawings, design details for the particular drawing may be provided on a separate sheet.
- 2.11.2 Scale shall be determined by the designer to suit the design details, and shall be included with the detail drawing. Scale of the detail shall allow for legibility when reduced to one-half size.
- 2.11.3 Where road cross-sections are required, they may be provided on a separate sheet.
- 2.11.4 Cross-sections shall be to a scale of 1:250 (H) to 1:50 (V) unless otherwise approved.
- 2.11.5 Starting at the lower left hand corner of the drawing sheet, cross-sections shall be placed up the sheet order of increasing stationing. Grid elevations shall be shown at the left-hand side of each cross section and stationing shall be shown below each cross-section. Adequate space shall be left between cross-sections so as to ensure clarity.
- 2.11.6 Cross-sections shall include:
 - (a) Design and road cross-section within the right-of-way.
 - (b) Existing ground cross-section extending into the adjacent properties as required.

2.12 AS-BUILT DRAWINGS

- 2.12.1 Drawings shall include all information as specified elsewhere for the construction drawings, but shall be corrected upon completion of construction to eliminate all works removed during construction and reflect "As-Built" conditions for permanent records.

- 2.12.2 All dimensions shall reflect the “As-Built” conditions of the construction and all references to “Proposed” shall be removed. “As-Built” drawings shall be to scale in accordance with the “As-Built” dimensions shown. The Revision Table shall be completed indicating the drawings as “As-Built”.
- 2.12.3 The “As-Built” drawings shall be submitted in digital format, dwg and PDF and on 3 mil Mylar so they can be reproduced by standard photocopying to provide clear and legible prints.
- 2.12.4 Line work for all constructed works shown on the drawings shall be drawn with the thicker line density (as for proposed works) for ease of determining the extent of works covered by the drawings. Proposed construction for future phases of the project shall not be shown on the “As-Built” drawings.
- 2.12.5 All drawings shall also include the following information:
- (a) The location and elevation of all existing utilities and services encountered in the construction operation.
 - (b) The location and invert elevation at property line of all individual service connections, and the wye chainage, at the main for all constructed and existing works.
 - (c) A note on each drawing describing the type of trench material (sand, gravel, clay, hard pan, etc.) encountered during construction and the location and profile of all rock.

The following information shall be submitted with the “As-Built” drawings:

- 2.12.6 Service cards for each lot showing the “As-Built” location of all service connections.
- 2.12.7 Street names approved by the District.
- 2.12.8 Statutory right-of-way and easement drawings.
- 2.12.9 Revised storm drainage calculations, if required, to reflect changes during the storm sewer construction.
- 2.12.10 Revised sanitary sewer calculations, if required, to reflect changes during the sanitary sewer construction.
- 2.12.11 Revised street light calculations, if required, to reflect changes during the street light installations.
- 2.12.12 All documents listed in District of Tofino – Subdivision Process Description and Flow chart – Step 7.

2.13 SITE PLAN

The Site Plan shall be revised to conform to the “As-Built” drawings and submitted on paper prints (3) and in CAD format as noted below. These drawings will be used as the basis for Municipal servicing overlays, and must clearly show the following information:

- (a) Standard information as noted in Section 2.3
- (b) Road alignment and lot layout
- (c) Schematic layout of water, sewer and storm drain systems, including the location of all valves, hydrants, manholes, catch basins and other appurtenances
- (d) Size and material type of all watermains, sewers and storm drains
- (e) Sidewalk location where required
- (f) Location of street lighting
- (g) Index of plan/profile design drawings

2.14 COMPUTER DRAFTING STANDARDS

The following are guidelines to assist in the standardization of computer-generated drawings submitted to the District of Tofino:

- 2.14.1 Drawings shall be 100% compatible with Auto CAD.
- 2.14.2 Drawing layers, pen colour and line types shall conform to MMCD standards.
- 2.14.3 Drawings shall be submitted in DWG and PDF format.
- 2.14.4 The MMCD drawing template shall be utilized.

Schedule 'F' - District of Tofino - Supplementary Specifications
Subdivision and Development Control Bylaw No. 1201, 2014

THIS PAGE IS INTENTIONALLY LEFT BLANK

“Schedule F” District of Tofino

Table of Contents and Explanation of Supplementary Standard Details

Supplementary Specifications - Amendment Register

Supplementary Detail Drawings

- Standard Detail Drawings in the Master Municipal Construction Documents are deleted and replaced by the listed Supplementary Detail Drawings.
- Minor changes to the MMCD Standard Detail Drawings are identified by highlighting the changes on the drawing list.
- More significant changes or additional details are presented as additional Supplementary Detail Drawings.

Concrete and Miscellaneous Details - Supplementary Details

General - Supplementary Details

Roadworks - Supplementary Details

Sanitary Sewer and Storm Drain - Supplementary Details

Watermain - Supplementary Details

Supplementary Specifications

MMCD 31 23 17 (Contractor Responsible for Survey, Monitoring, Control)

Concrete and Miscellaneous - Drawing Index

| Concrete and Miscellaneous Details | | | |
|------------------------------------|--|------------------------------------|---|
| MMCD Standard Detail Drawing | | Tofino Supplemental Detail Drawing | |
| C1 | Concrete Sidewalk, Infill and Barrier Curb | | Use MMCD Drawing No expansion joint material between sidewalk and curb – use bond break |
| C2 | Concrete Sidewalk and Barrier Curb | | Use MMCD Drawing No expansion joint material between sidewalk and curb – use bond break |
| C3 | Concrete Sidewalk and Rollover Curb | | Use MMCD Drawing Sidewalk thickness minimum 150mm No expansion joint material between sidewalk and curb – use bond break |
| C4 | Concrete Curbs – Narrow Base | | Use MMCD Drawing Thicken concrete curb by 150mm, or reinforce with 2 – 15M bars at industrial, commercial, and multi family (over 2 residences) crossings. |
| C5 | Concrete Barrier Curb – Wide Base | | Use MMCD Drawing Thicken concrete curb by 300mm, or reinforce with 2 – 15M bars at industrial, commercial, and multi family (over 2 residences) crossings. |
| C6 | Concrete Median Curb and Interim Curbs | | Use MMCD Drawing |
| | | C6A-SD | Valley Curb and Flat Curb |
| C7 | Driveway Crossing and Barrier Curbs | | Do Not Use |
| | | C7A-SD | Typical Sidewalk and Driveway Crossing – Type 1 |
| | | C7B-SD | Typical Sidewalk and Driveway Crossing – Type 2 |
| | | C7C-SD | Typical Sidewalk and Driveway Crossing - Type 3 |
| | | C7D-SD | Typical Sidewalk Construction and Finishing Details |
| C8 | Wheelchair Ramp for Sidewalk, Infill, and Barrier Curb | | Do Not Use |
| | | C8A-SD | Pedestrian Sidewalk Ramp for Non Mountable Curb - Single |
| | | C8B-SD | Pedestrian Sidewalk Ramp for Non-Mountable Curb - Double |
| C10 | Concrete Walkway | | Do Not Use |
| C11 | Bicycle Baffle | | Use MMCD Drawing |

Schedule 'F' - District of Tofino - Supplemental Specifications

Concrete and Miscellaneous - Drawing Index

| | | | |
|-----|-------------------------------------|--------|---|
| C12 | Removable Restriction Post | | Use MMCD Drawing Provide restrictions at 1.5m each side of posts to ensure that vehicle traffic is restricted. |
| C13 | Chain Link Fence for Walkway | | Use MMCD Drawing |
| C14 | Handrail on Concrete Retaining Wall | | Use MMCD Drawing |
| | | C15-SD | Curb Extension Detail |
| | | C16-SD | Temporary Asphalt Curb |

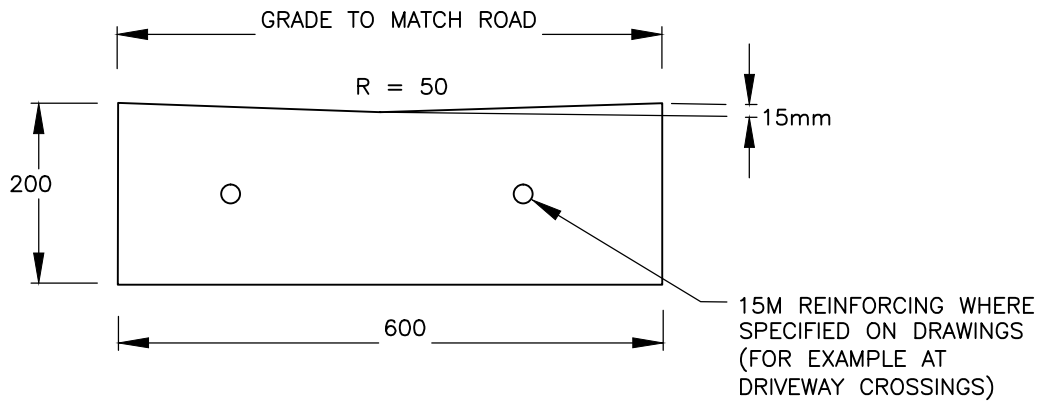

VALLEY CURB

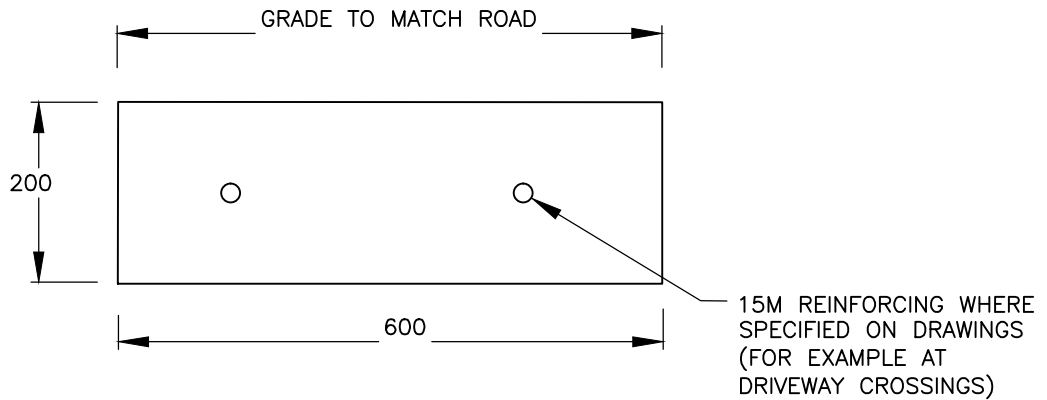

FLAT CURB

1. CURB AND GUTTER TO BE BEDDED ON MIN 100mm OF COMPACTED THICKNESS OF 20mm MINUS CRUSHED GRAVEL.
2. AT LOCATIONS OTHER THAN PEDESTRIAN CURB LETDOWNS, THE LENGTH OF TRANSITION FROM ONE TYPE OF CURB TO ANOTHER SHALL BE 2.0 METRES.
3. MIDPOINT OF CURB SHALL ALIGN WITH THE UPSTREAM AND DOWNSTREAM CURB FACES.
4. THICKEN CURB AS REQUIRED IN HEAVY TRAFFIC AREAS.

| | | | | |
|---|---------------|---|---------------------------------|-----------|
| 3 | | DIMENSIONS ARE IN MILLIMETERS UNLESS OTHERWISE NOTED | | |
| 2 | | TITLE VALLEY CURB AND FLAT CURB | | |
| 1 | | | | |
| | REVISION DATE | APPROVED | | |
|  DISTRICT OF TOFINO | | SUBDIVISION & DEVELOPMENT CONTROL BYLAW | APPROVED | |
| | | | DATE | OCT, 2015 |
| | | | DRAWN BY | JEA |
| | | | DRAWING NUMBER C6A-SD | |

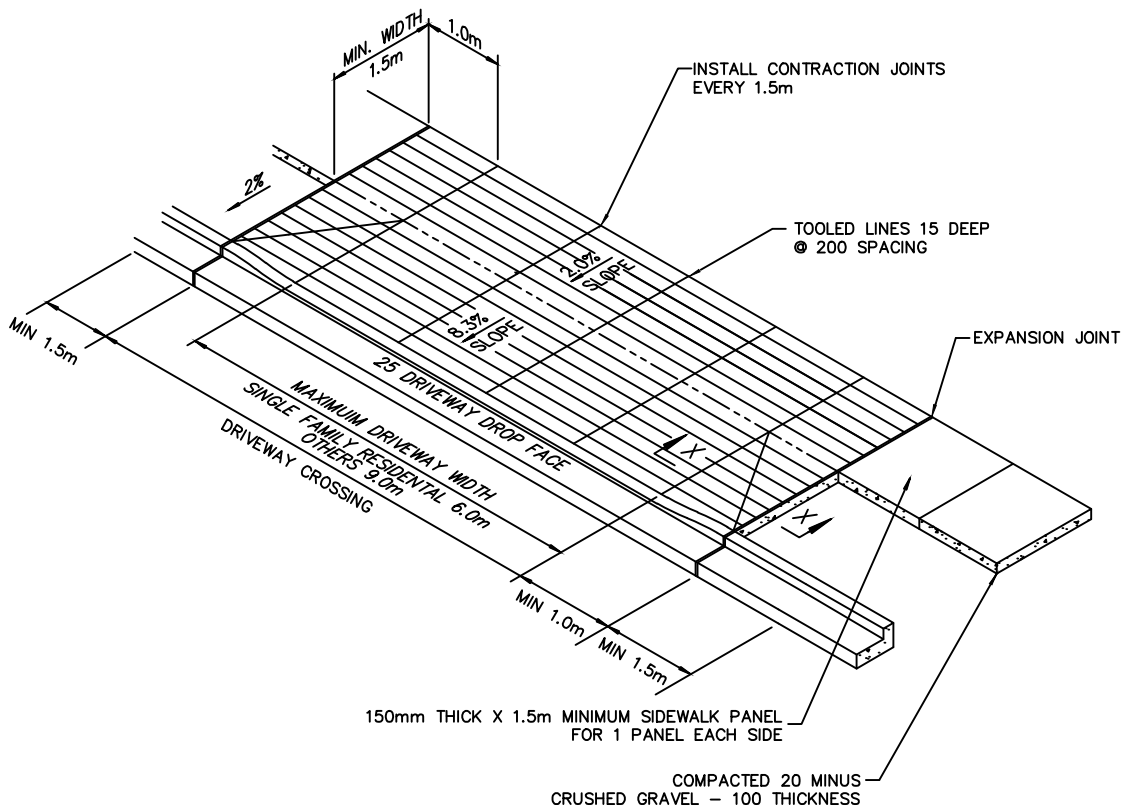

ISOMETRIC

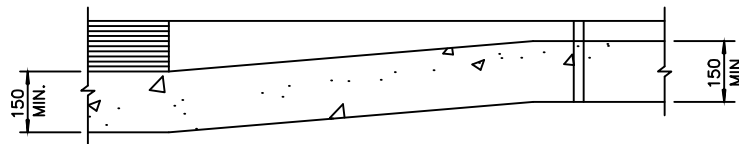

SECTION X-X

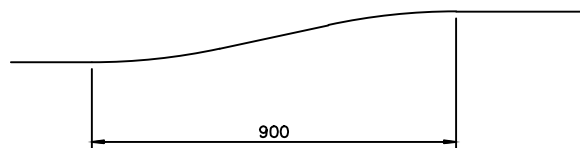

CURB DROP DETAIL

NOTES:

1. MINIMUM CONCRETE SIDEWALK AND APPROACH THICKNESS SHALL BE 150 MINIMUM AS SHOWN, EXCEPT 200 FOR TRUCK TRAFFIC.
2. ALL LANE ACCESSES AND MULTI-FAMILY, COMMERCIAL AND INDUSTRIAL ACCESSES SHALL HAVE THE CURB REINFORCED OR THICKENED.

| | | | | |
|---|---------------|---|--|----------------|
| 3 | | | DIMENSIONS ARE IN MILLIMETERS UNLESS OTHERWISE NOTED | |
| 2 | | | TITLE TYPICAL SIDEWALK AND DRIVEWAY CROSSING – TYPE 3 | |
| 1 | | | APPROVED | DRAWING NUMBER |
| | REVISION DATE | APPROVED | DATE OCT, 2015 | C7C-SD |
| | | | DRAWN BY JEA | |
|  DISTRICT OF TOFINO | | SUBDIVISION & DEVELOPMENT CONTROL BYLAW | | |

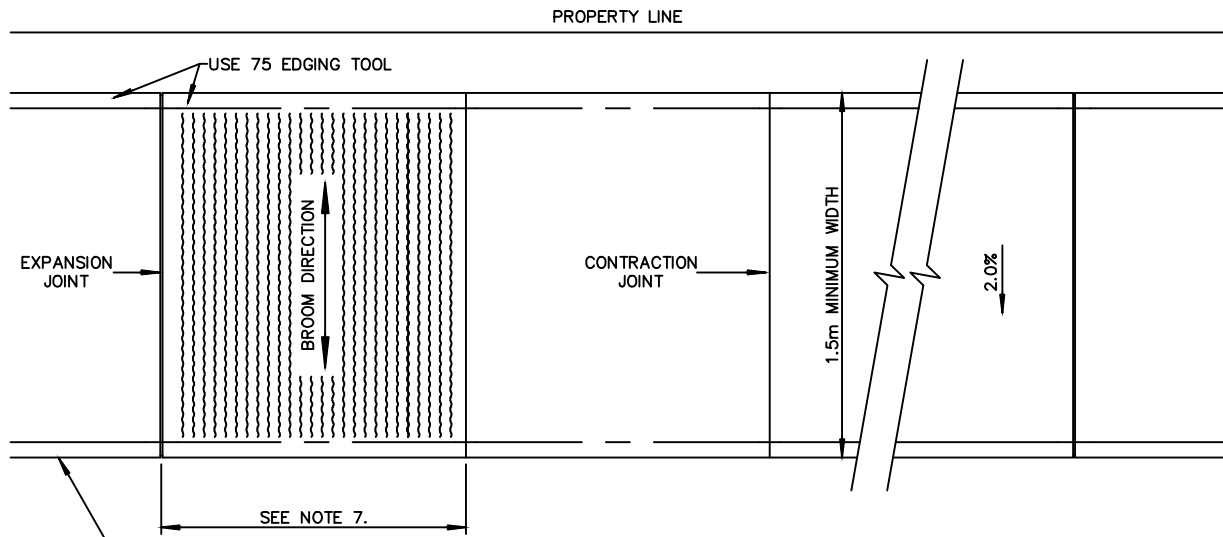

CONTRACTION JOINT IF SIDEWALK IS POURED INTEGRALLY TO CURB. ISOLATION JOINT IF SIDEWALK IS POURED ADJACENT TO CURB. BOND BREAK COMPOUND MAY BE USED WHERE APPROVED BY THE SUPERINTENDENT.

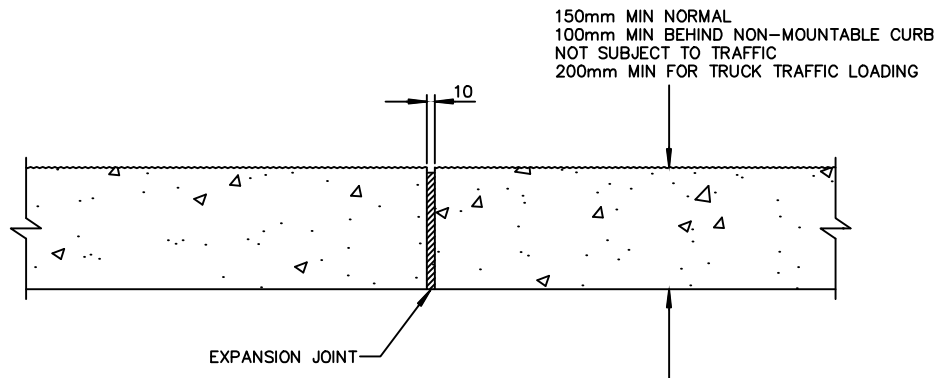

NOTES:
1. SIDEWALKS SHALL HAVE BROOMED FINISH.

| | | | | | |
|---|---|---|--|---------------------------------|-----------|
| 3 | | DIMENSIONS ARE IN MILLIMETERS UNLESS OTHERWISE NOTED | | | |
| 2 | | | | | |
| 1 | | | | | |
| | REVISION DATE | APPROVED | TITLE TYPICAL SIDEWALK CONSTRUCTION AND FINISHING DETAILS | | |
|  DISTRICT OF TOFINO | SUBDIVISION & DEVELOPMENT CONTROL BYLAW | | APPROVED | DRAWING NUMBER C7D-SD | |
| | | | DATE | | OCT, 2015 |
| | | | DRAWN BY | | JEA |

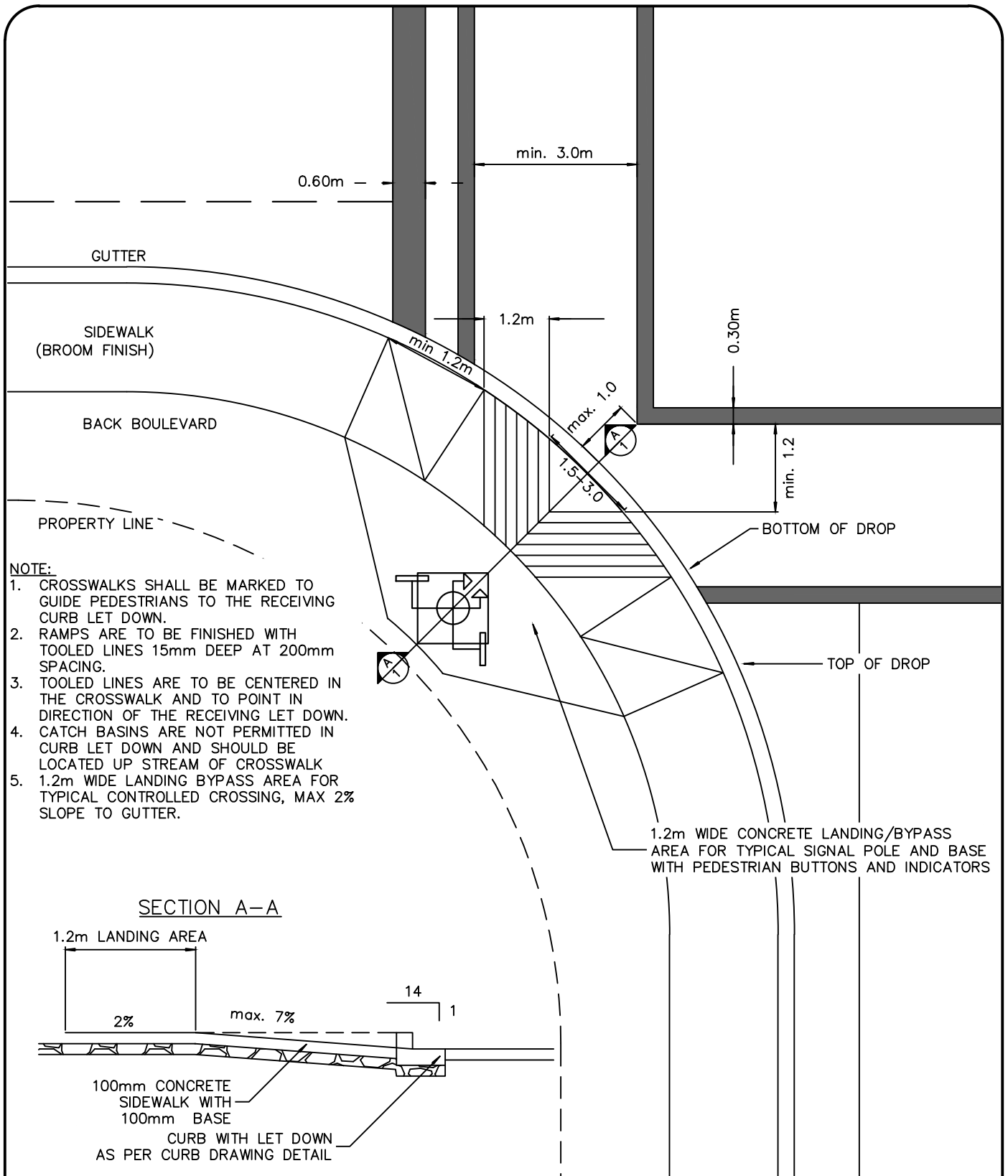

NOTE:

1. CROSSWALKS SHALL BE MARKED TO GUIDE PEDESTRIANS TO THE RECEIVING CURB LET DOWN.
2. RAMPS ARE TO BE FINISHED WITH TOOLED LINES 15mm DEEP AT 200mm SPACING.
3. TOOLED LINES ARE TO BE CENTERED IN THE CROSSWALK AND TO POINT IN DIRECTION OF THE RECEIVING LET DOWN.
4. CATCH BASINS ARE NOT PERMITTED IN CURB LET DOWN AND SHOULD BE LOCATED UP STREAM OF CROSSWALK
5. 1.2m WIDE LANDING BYPASS AREA FOR TYPICAL CONTROLLED CROSSING, MAX 2% SLOPE TO GUTTER.

SECTION A-A

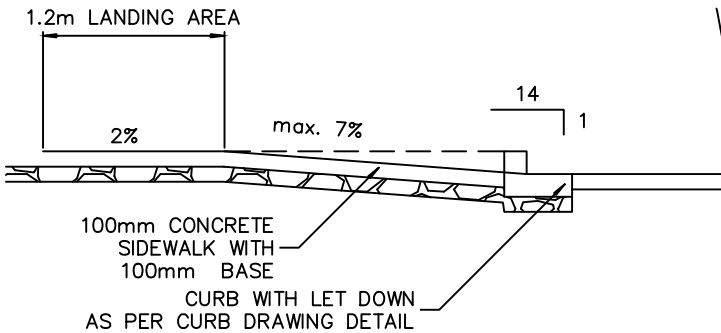

| | | | |
|---|---|--|---------------------------------|
| 3 | | DIMENSIONS ARE IN MILLIMETERS UNLESS OTHERWISE NOTED | |
| 2 | | TITLE PEDESTRIAN SIDEWALK RAMP FOR NON-MOUNTABLE CURB – SINGLE | |
| 1 | | | |
| | REVISION DATE | APPROVED | DRAWING NUMBER C8A-SD |
|  | DISTRICT OF TOFINO | | |
| | SUBDIVISION & DEVELOPMENT CONTROL BYLAW | | |
| | | APPROVED | |
| | | DATE | OCT, 2015 |
| | | DRAWN BY | JEA |

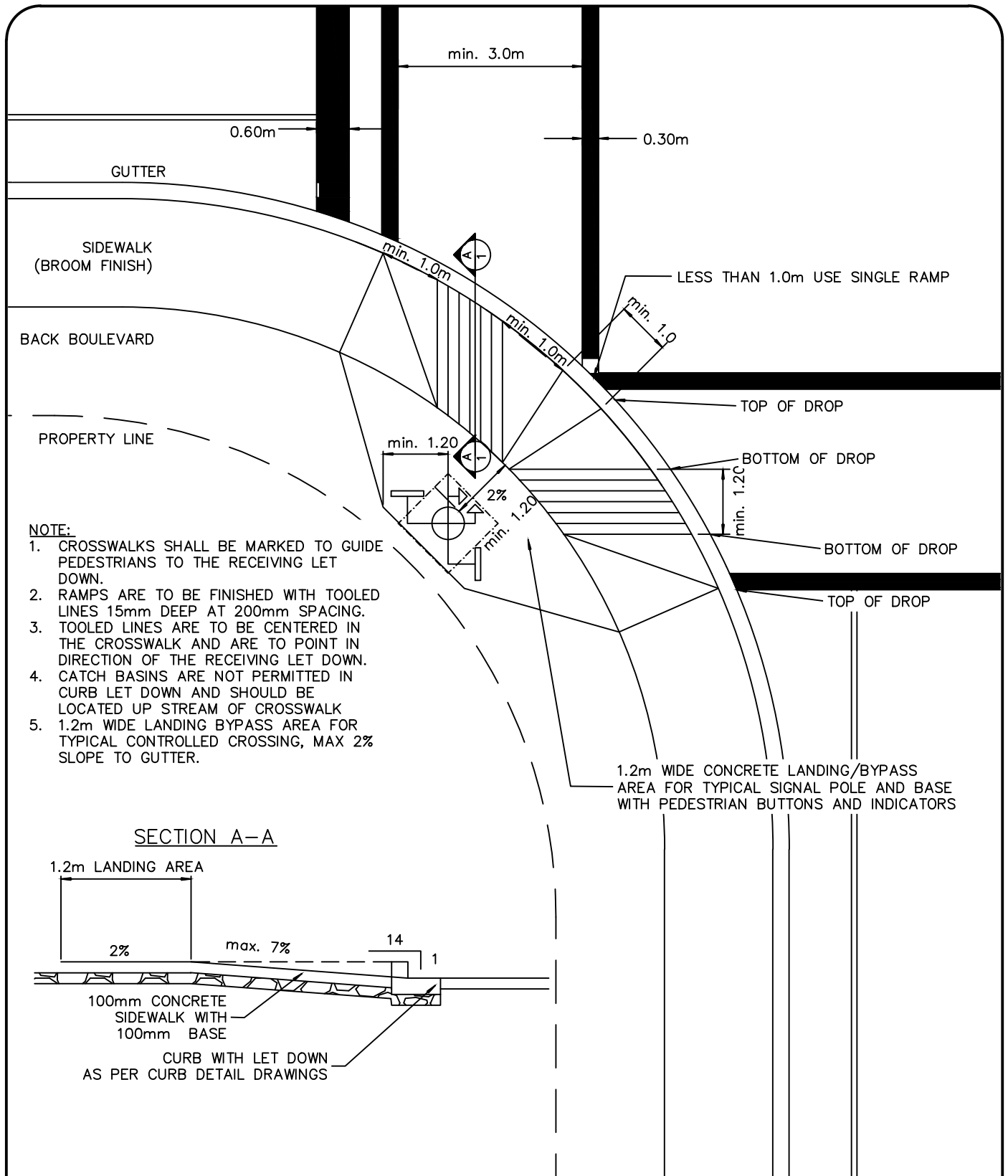

SECTION A-A

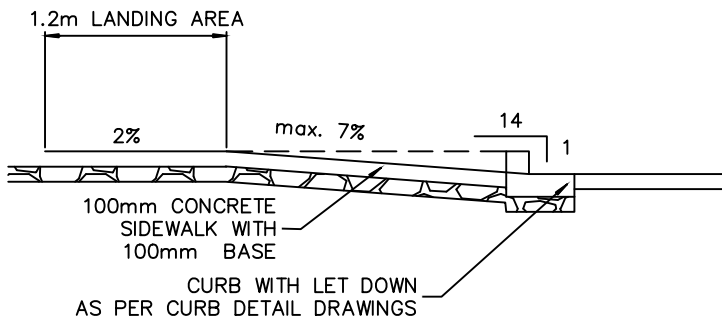

| | | | |
|---|--|---|--|
| 3 | | DIMENSIONS ARE IN MILLIMETERS UNLESS OTHERWISE NOTED | |
| 2 | | | |
| 1 | | | |
| REVISION DATE | | APPROVED | |
|  DISTRICT OF TOFINO | | SUBDIVISION & DEVELOPMENT CONTROL BYLAW | |
| | | TITLE PEDESTRIAN SIDEWALK RAMP FOR NON-MOUNTABLE CURB – DOUBLE | |
| | | APPROVED DATE OCT, 2015 DRAWN BY JEA | |
| | | DRAWING NUMBER C8B-SD | |

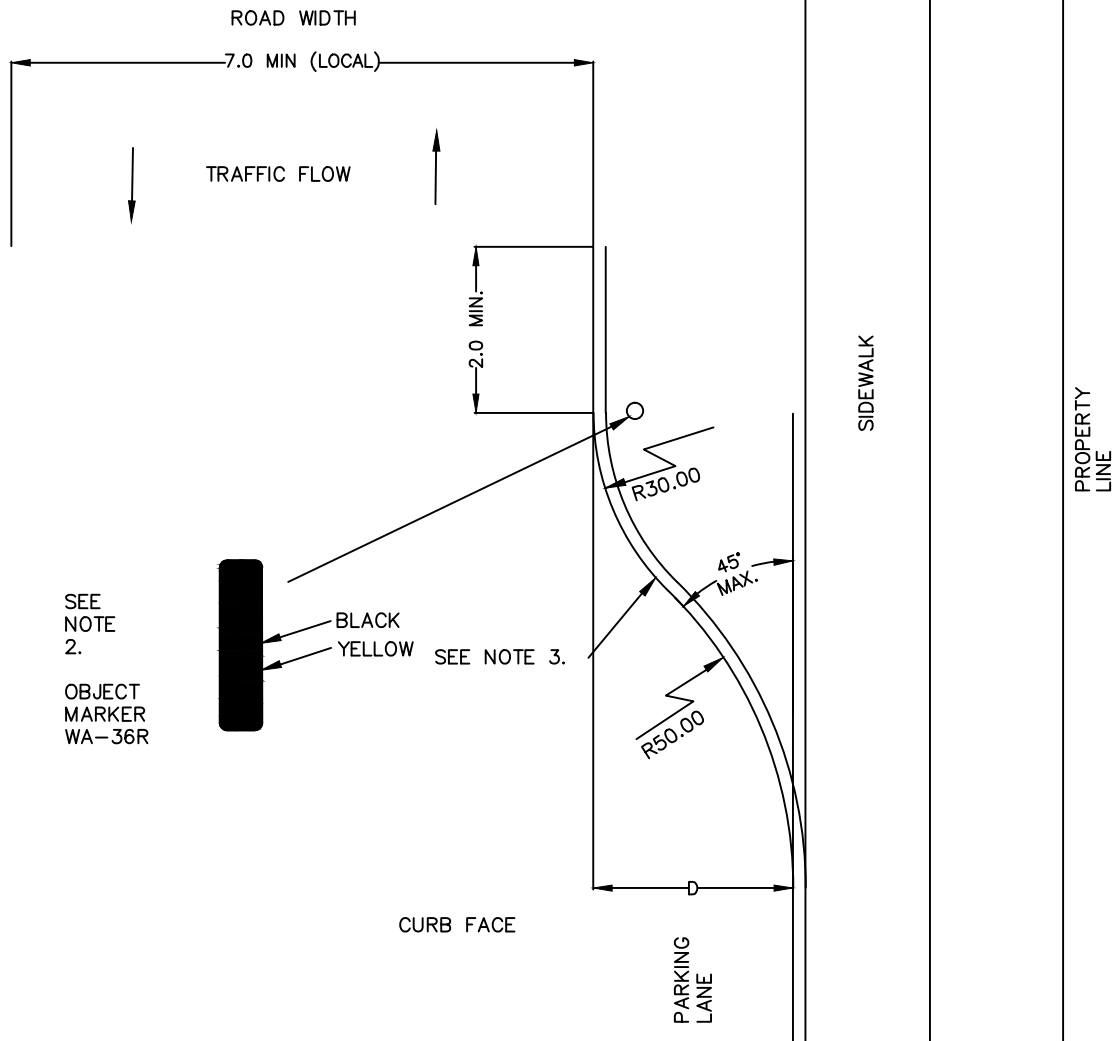

NOTES:

1. "D"=DEPTH OF CURB EXTENSION SHOULD BE SIMILAR TO THE WIDTH OF THE PARKING LANE (TYPICALLY, 2.4m); EXCEPT ON LOCAL STREETS WHERE THE MINIMUM CURB EXTENSION DEPTH MAY BE REDUCED, WHERE REQUIRED, TO MAINTAIN A MINIMUM THROAT WIDTH OF 7.0m.
2. IF THE START OF THE PARKING LANE IS MORE THAN 75m IN ADVANCE OF THE CURB EXTENSION OR WHERE THE CURB EXTENSION MAY BE A HAZARD TO VEHICLE IN THE ADJACENT TRAVEL LANE INCLUDE AN OBJECT MARKER (WA-36R) ON THE CURB EXTENSION.
3. INCLUDE A TANGENT AT 45° TO THE CURB FACE BETWEEN RADII WHERE "D" IS GREATER THAN 2.4m.
4. STREET DESIGN REQUIRED FOR DRAINAGE.
5. NO STREET TREES IN THE FRONT BOULEVARD WITHIN CURB EXTENSION.
6. FOR DESIGNS, WITH NON LOCAL ROAD CLASSIFICATIONS AND/OR BUS ROUTE STATUS THE SUPERINTENDENT SHALL BE CONSULTED PRIOR TO DESIGN STAGE.

| | | | |
|--|---------------|---|---------------------------------------|
| 3 | | DIMENSIONS ARE IN MILLIMETERS UNLESS OTHERWISE NOTED | |
| 2 | | | |
| 1 | | | |
| | REVISION DATE | APPROVED | TITLE CURB EXTENSION DETAIL |
|  DISTRICT OF TOFINO SUBDIVISION & DEVELOPMENT CONTROL BYLAW | APPROVED | | DRAWING NUMBER |
| | DATE | | OCT, 2015 |
| | DRAWN BY | | JEA |
| | | | C15-SD |

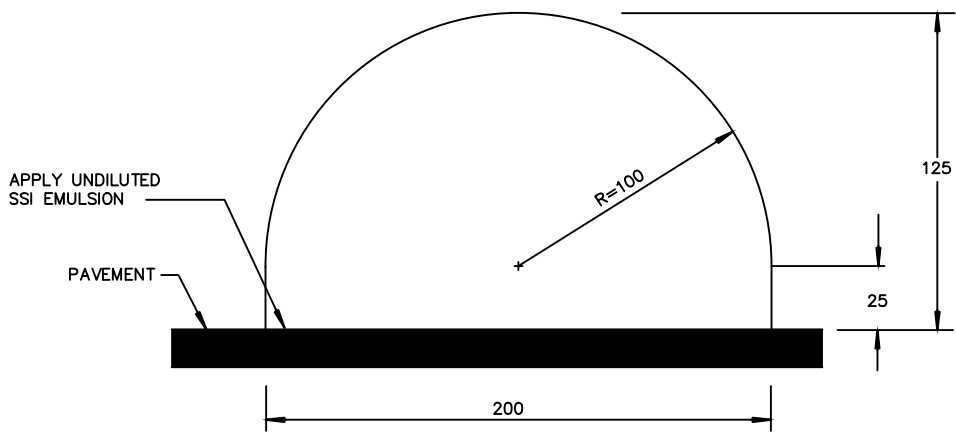

100mm ASPHALT CURB
MACHINE PLACED

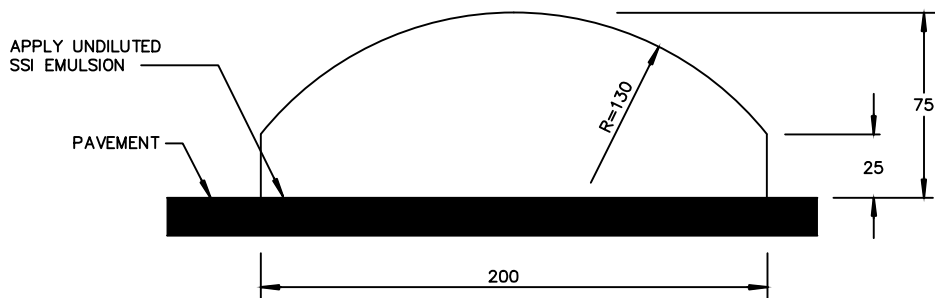

75mm ASPHALT CURB
MACHINE PLACED

NOTES

1. CURBS SHALL BE INSTALLED ON PAVED SURFACES
2. DROP CURB, 75 HIGH REQUIRED AT ALL DRIVEWAY AND LANE CROSSINGS

| | | |
|---|---|---|
| 3 | | DIMENSIONS ARE IN MILLIMETERS UNLESS OTHERWISE NOTED |
| 2 | | |
| 1 | | TITLE |
| | REVISION DATE APPROVED | TEMPORARY ASPHALT CURB |
|  DISTRICT OF TOFINO | SUBDIVISION & DEVELOPMENT CONTROL BYLAW | APPROVED |
| | | DATE OCT, 2015 |
| | | DRAWN BY JEA |
| | | DRAWING NUMBER C16-SD |

Schedule 'F' - District of Tofino - Supplemental Specifications

General Details - Drawing Index

| General | | | |
|------------------------------|--|------------------------------------|--|
| MMCD Standard Detail Drawing | | Tofino Supplemental Detail Drawing | |
| G1 | General Legend for Contract Drawings | | Use MMCD Drawing |
| G2 | Legend for Materials | | Use MMCD Drawing |
| G3 | Legend for Street Lights and Traffic Signal Drawings | | Use MMCD Drawing |
| G4 | Utility Trench | | Use MMCD Drawing Minimum 150mm of bedding below pipe in rock. |
| | | G4A-SD | Sanitary and Storm Sewer in Common Trench |
| G5 | | | Use MMCD Drawing Pavement Restoration asphalt thickness can be minimum 50mm asphalt thickness on local roads, but match existing asphalt thickness to maximum 80mm. |
| G6 | Concrete Encasement for Watermain / Sewer Separation | | Use MMCD Drawing |
| G7 | Concrete Protection for Underground Utilities | | Use MMCD Drawing |
| G8 | Pipe Anchor Blocks | | Do Not Use |
| | | G8A-SD | Trench Dams for Utility Mains |
| | | G9-SD | Typical Location of Service Connections to Residential Vacant Lots |
| | | G10-SD | Private Utilities – Underground Electrical Common Trench Details |
| | | G11-SD | Private Utilities – Underground Electrical Typical Service Box Locations |
| | | G12-SD | Bollard Light |

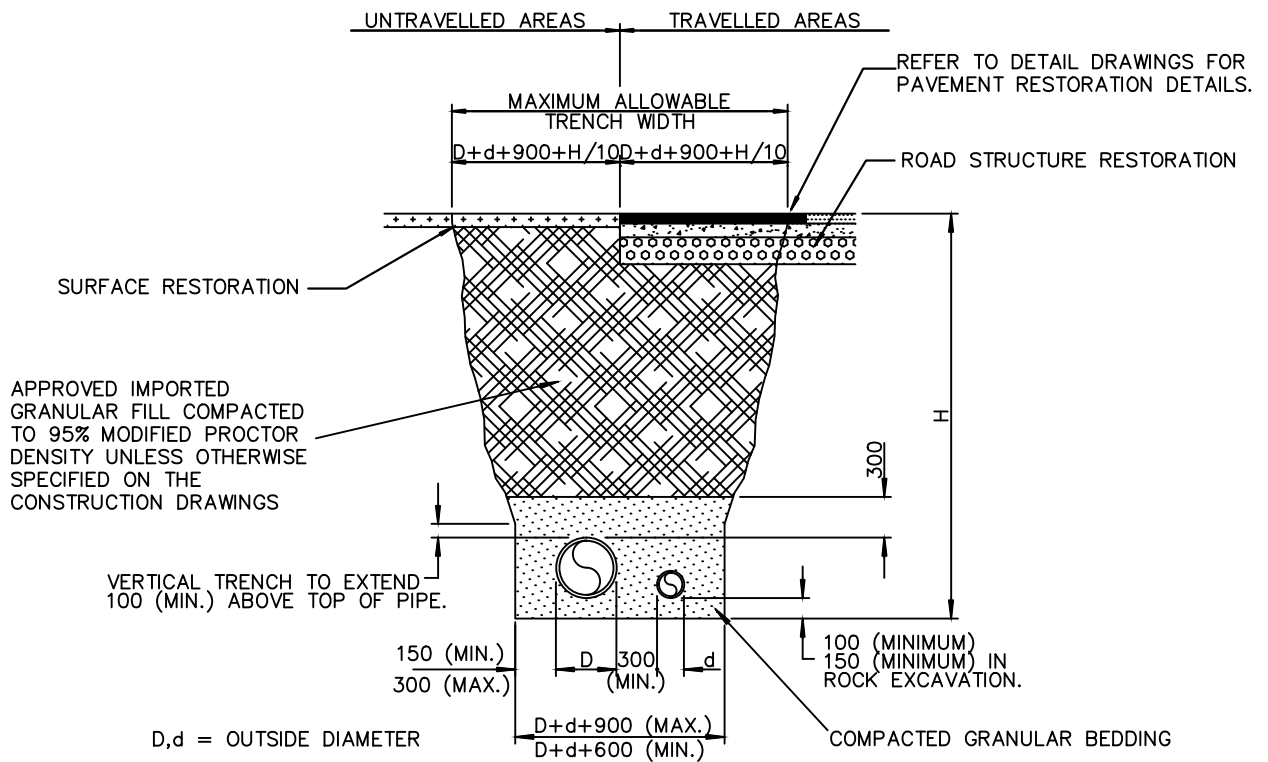
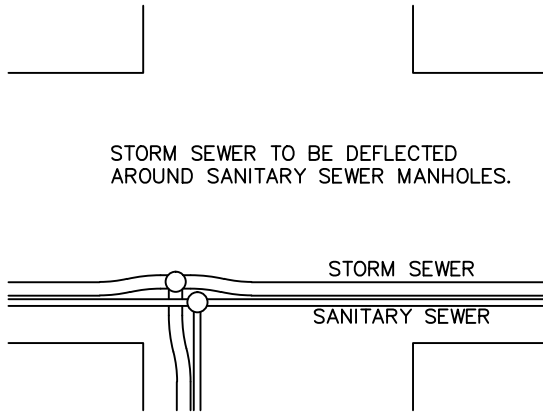

| | | | | |
|---|-------------------------------|--|---------------------|---------------------------------|
| 3 | | DIMENSIONS ARE IN MILLIMETERS UNLESS OTHERWISE NOTED | | |
| 2 | | | | |
| 1 | | | | |
| | REVISION DATE APPROVED | TITLE SANITARY AND STORM SEWER IN COMMON TRENCH | | |
|  | DISTRICT OF TOFINO | SUBDIVISION & DEVELOPMENT CONTROL BYLAW | APPROVED | DRAWING NUMBER G4A-SD |
| | | | DATE OCT, 2015 | |
| | | | DRAWN BY JEA | |

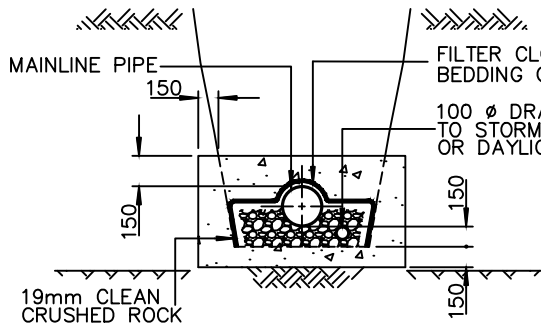

SECTION A-A

DETAIL OF DRAIN PIPE

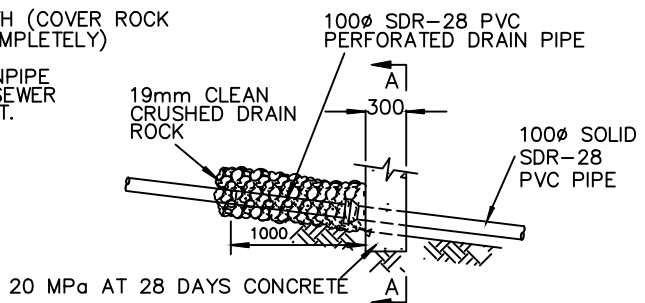

PROFILE

ALTERNATIVE 1
FOR USE IN SILTS AND OTHER STABLE,
WELL COMPACTED NATIVE MATERIALS.

NOTE: MAINLINE PIPE &
FILTER CLOTH NOT
SHOWN FOR CLARITY.

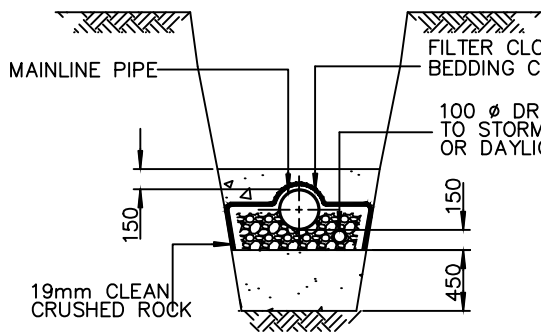

SECTION B-B

DETAIL OF DRAIN PIPE

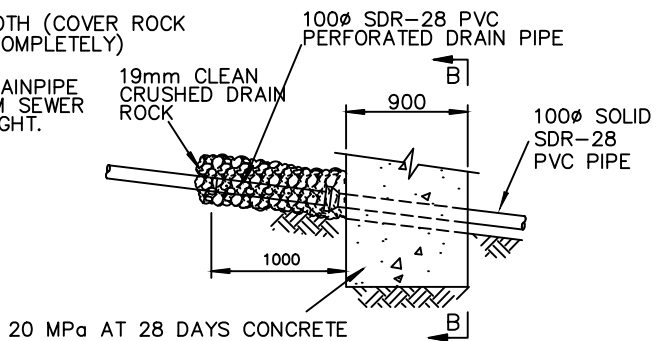

PROFILE

ALTERNATIVE 2
FOR USE IN CLEAN GRAVELS, SANDS AND
OTHER LOOSE, PERMEABLE NATIVE MATERIALS.

NOTE: MAINLINE PIPE &
FILTER CLOTH NOT
SHOWN FOR CLARITY.

TRENCH DAM KEYED IN
TO TRENCH WALL ON
SOFT SOIL CONDITIONS.

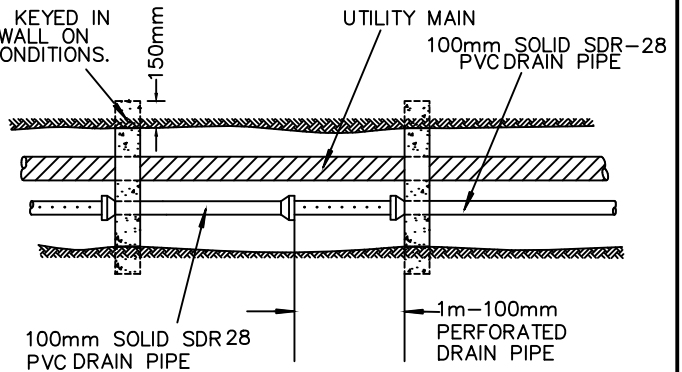

TYPE 1-PLAN VIEW

| MAXIMUM SPACING OF ANCHOR BLOCKS | | | |
|-----------------------------------|--------------|---------------------------|--------------|
| SANITARY AND STORM GRAVITY SEWERS | | WATERMAINS AND FORCEMAINS | |
| SLOPE | MAX. SPACING | SLOPE | MAX. SPACING |
| 15% - 20% | 25m | 10% OR GREATER | 10m |
| 20% - 35% | 20m | | |
| 35% - 50% | 15m | | |
| 50% - OVER | 10m | | |

NOTES:

- IF APPROVED BY THE ENGINEER, IN AREAS INACCESSIBLE BY CONSTRUCTION EQUIPMENT, WET, PRE-MIXED CONCRETE FILLED SANDBAGS MAY BE USED.
- PROVIDE TRENCH DRAINAGE TO AN ACCEPTABLE WATERCOURSE OR STORM COLLECTION SYSTEM FROM EVERY TRENCH DAM. HIGHEST END OF THE TRENCH DAM DRAIN PIPE SHALL BE CAPPED.
- ALL PIPE TO BE SDR-28 PVC.

| | | |
|---|---------------|----------|
| 3 | | |
| 2 | | |
| 1 | | |
| | REVISION DATE | APPROVED |

DIMENSIONS ARE IN MILLIMETERS
UNLESS OTHERWISE NOTED

TITLE **TRENCH DAMS FOR
UTILITY MAINS**



**DISTRICT OF
TOFINO**

SUBDIVISION &
DEVELOPMENT
CONTROL BYLAW

| | |
|----------|-----------|
| APPROVED | |
| DATE | OCT, 2015 |
| DRAWN BY | JEA |

DRAWING NUMBER
G8A-SD

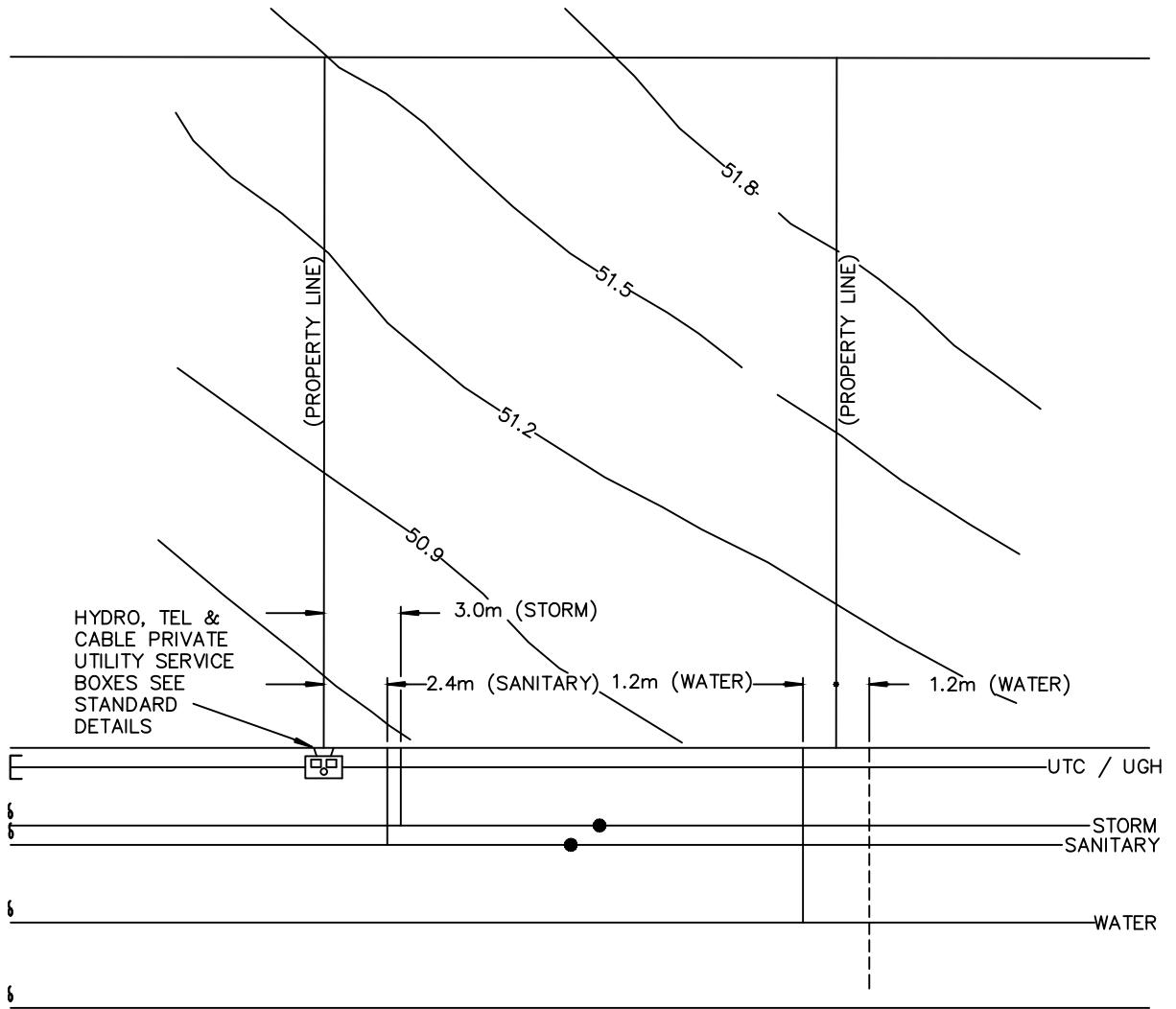

NOTES:

1. SANITARY AND STORM SEWER SERVICES TO BE INSTALLED ON THE LOWER SIDE OF THE LOT.
2. POLE RESERVE, IF REQUIRED, TO BE AT ALTERNATE LOT CORNER TO WATER SERVICES.

| | | | | | |
|---|---|---|--|--------------------------------|-----------|
| 3 | | DIMENSIONS ARE IN MILLIMETERS UNLESS OTHERWISE NOTED | | | |
| 2 | | | | | |
| 1 | | | | | |
| | REVISION DATE | APPROVED | TITLE TYPICAL LOCATION OF SERVICE CONNECTIONS TO RESIDENTIAL VACANT LOTS | | |
|  DISTRICT OF TOFINO | SUBDIVISION & DEVELOPMENT CONTROL BYLAW | | APPROVED | DRAWING NUMBER G9-SD | |
| | | | DATE | | OCT, 2015 |
| | | | DRAWN BY | | JEA |

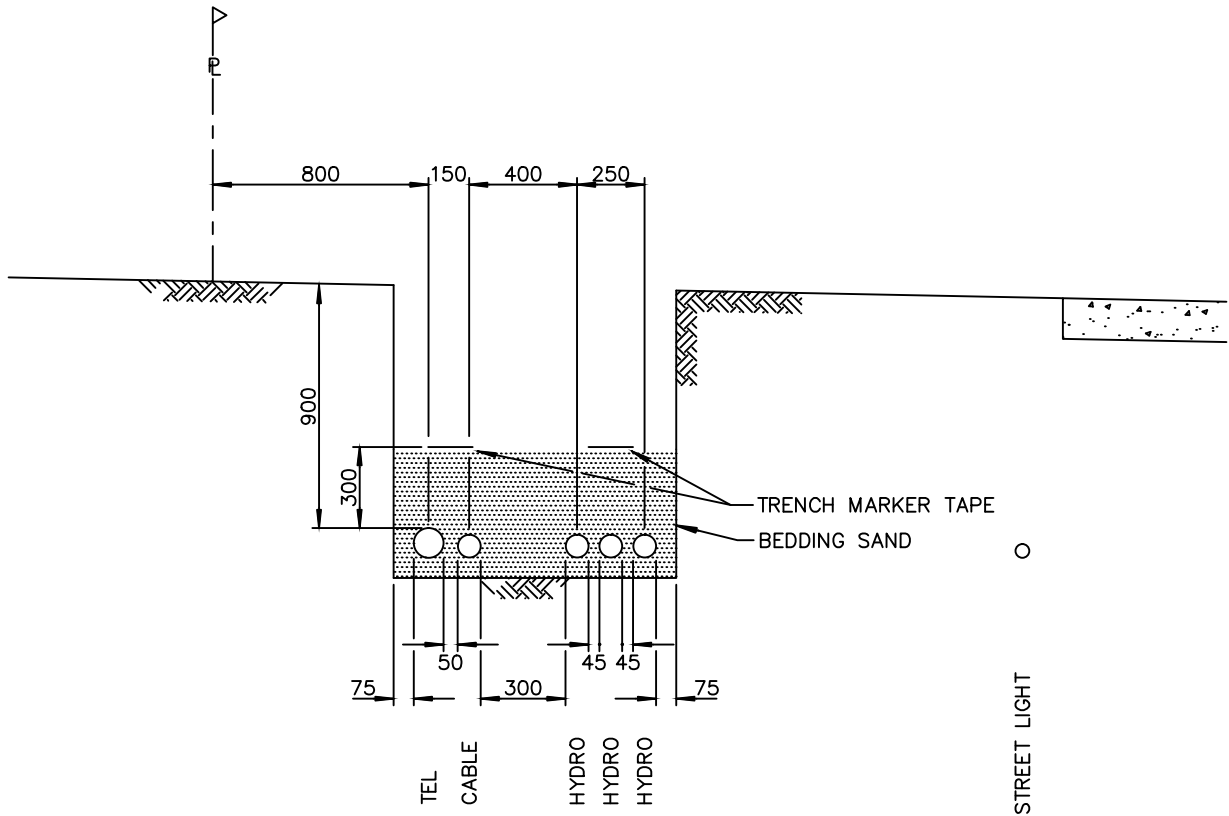

THE ABOVE DIMENSIONS ARE MINIMUMS.
SEE UTILITY COMPANY DRAWING FOR
DETAILS

- NOTE:
2. REFER TO UTILITY CONSTRUCTION DRAWINGS FOR DUCT SIZE AND OTHER CONSTRUCTION REQUIREMENTS.
 3. ALL UTILITIES SHALL BE TRACEABLE ELECTRONICALLY

| | | | | | |
|---|---------------|---|--|---------------------------------|-----------|
| 3 | | DIMENSIONS ARE IN MILLIMETERS UNLESS OTHERWISE NOTED | | | |
| 2 | | | | | |
| 1 | | | | | |
| | REVISION DATE | APPROVED | TITLE PRIVATE UTILITIES – UNDERGROUND ELECTRICAL COMMON TRENCH DETAILS | | |
|  DISTRICT OF TOFINO | | SUBDIVISION & DEVELOPMENT CONTROL BYLAW | APPROVED | DRAWING NUMBER G10-SD | |
| | | | DATE | | OCT, 2015 |
| | | | DRAWN BY | | JEA |

APPROXIMATE DIMENSIONS (mm)

HYDRO BOX: 750 ϕ
 TEL BOX : 750x1000
 CABLE BOX: 750x1000

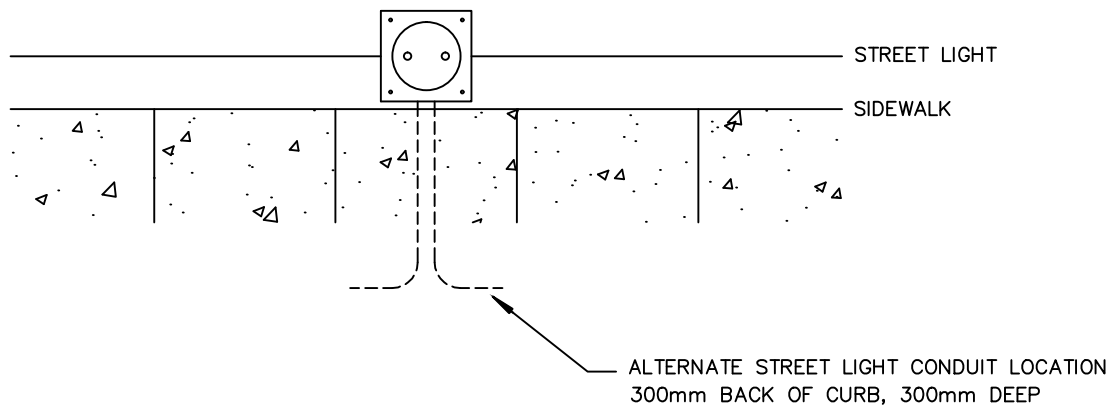
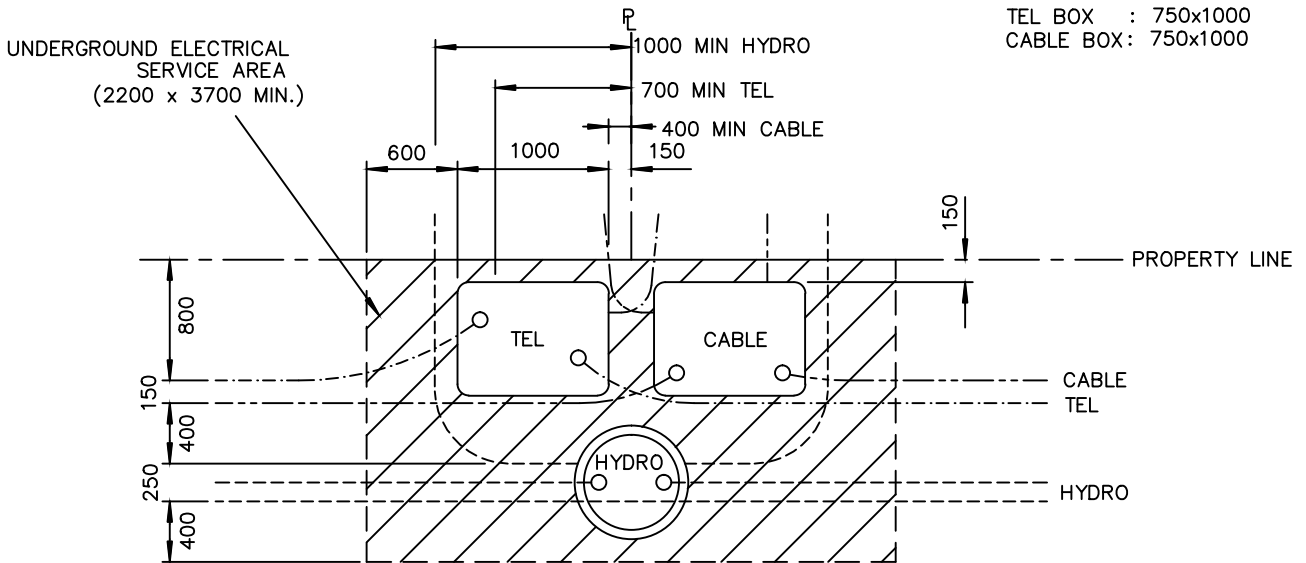

NOTE:

1. FOR STREET LIGHT OFFSETS LESS THAN 3.00m, HYDRANTS AND STREET LIGHT POLES SHALL NOT BE LOCATED WITH UNDERGROUND ELECTRICAL SERVICES.
2. SERVICE BOXES SHALL HAVE MINIMUM SEPARATION OF 300mm.
3. REFER TO UTILITY CONSTRUCTION DRAWINGS FOR FURTHER DETAILS.
4. ALL UTILITIES SHALL BE TRACEABLE ELECTRONICALLY.

| | | | |
|---|--|---|----------------|
| 3 | | DIMENSIONS ARE IN MILLIMETERS UNLESS OTHERWISE NOTED | |
| 2 | | TITLE PRIVATE UTILITIES – UNDERGROUND ELECTRICAL TYPICAL SERVICE BOX LOCATIONS | |
| 1 | | REVISION DATE | APPROVED |
|  DISTRICT OF TOFINO | | SUBDIVISION & DEVELOPMENT CONTROL BYLAW | |
| | | APPROVED | DRAWING NUMBER |
| | | DATE | OCT, 2015 |
| | | DRAWN BY | JEA |
| | | G11-SD | |



06/05/2015 07:22

| | | | | | |
|---|---|----------|----------|---------------------------------|-----------|
| 3 | | | | | |
| 2 | | | | | |
| 1 | | | TITLE | BOLLARD LIGHT | |
| | REVISION DATE | APPROVED | | | |
|  DISTRICT OF TOFINO | SUBDIVISION & DEVELOPMENT CONTROL BYLAW | | APPROVED | DRAWING NUMBER G12-SD | |
| | | | DATE | | OCT, 2015 |
| | | | DRAWN BY | | JEA |

Schedule 'F' - District of Tofino - Supplemental Specifications

Roadworks Details - Drawing Index

| Roadworks | | | |
|------------------------------|-----------------|------------------------------------|--|
| MMCD Standard Detail Drawing | | Tofino Supplemental Detail Drawing | |
| R1 | Paved Shoulders | | Use MMCD Drawing |
| | | R2-SD | Typical Driveway Grades at Curbs |
| | | R3-SD | Typical Driveway Grades at Gravel Shoulders |
| | | R4-SD | Perforated Steel Base for Signs |
| | | R5-SD | Standard Traffic Sign Installation Details |
| | | R6-SD | Commercial and Industrial Standard Cul-de-Sacs |
| | | R7-SD | Local Standard Cul-de-Sac |

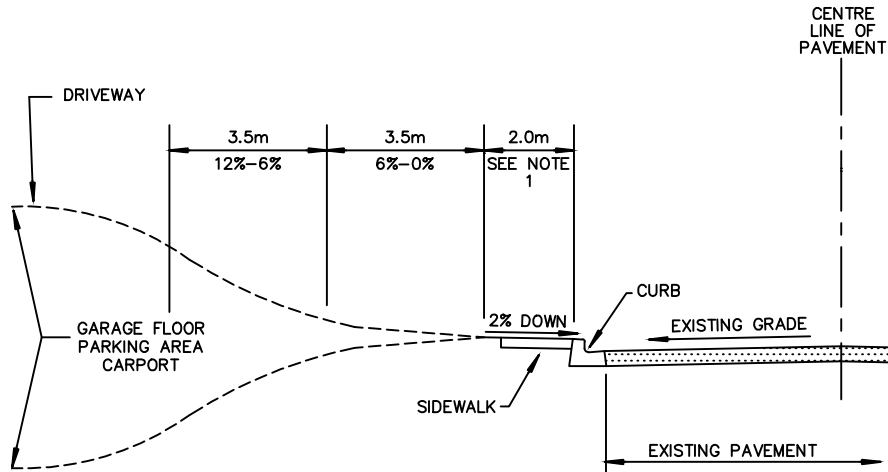

COLLECTOR ROADS

NOTES:

1. THE MAXIMUM GRADE OF THE DRIVEWAY SHALL BE 20% WITH A CHANGE IN RISE OR FALL NOT EXCEEDING 6% (COLLECTOR ONLY) FOR EACH HORIZONTAL 3.5m. THE RISE OR FALL OF THE DRIVEWAY SHALL BEGIN 2.0m BEHIND THE CURB TOWARDS THE PROPERTY.
2. THE SLOPE OF THE EDGES OF THE DRIVEWAY OR FILL SHALL BE A MAXIMUM OF 1 VERTICAL TO 1.5 HORIZONTAL ROCK SLOPES AND CUTS SHALL BE A MAXIMUM OF 4 VERTICAL TO 1 HORIZONTAL.
3. DRIVEWAYS ARE NOT TO EXCEED 6.0 METRES IN WIDTH WITHIN THE STREET.
4. MAXIMUM NUMBER OF DRIVEWAYS PER LOT IS TWO. TOTAL WIDTH FOR THE TWO DRIVEWAYS SHALL NOT EXCEED 6.0 METRES WITHIN THE STREET.
5. DRIVEWAY ACCESS MUST BE LOCATED AT A MINIMUM DISTANCE OF 7 METRES FROM THE INTERSECTION OF ANY 2 ROADS AND 0.75 METRES FROM THE BASE OF ANY BOULEVARD TREE.
6. OWNER/AGENT IS TO SUBMIT A PLAN SHOWING LOCATION AND PROFILE OF DRIVEWAY, BUILDING LOCATION, ELEVATION OF GARAGE/PARKING AREA RELATIVE TO THE BACK OF THE EXISTING CURB AND LOCATION OF EXISTING BOULEVARD PLANTINGS.
7. DRIVEWAY IS TO BE ROUGH GRADED TO PUBLIC WORKS APPROVAL.
8. ALL WATER AND SEWER ACCESSES AND/OR CLEANOUTS WITHIN PROPOSED DRIVEWAY SHALL BE PROTECTED IN ACCORDANCE WITH THE DISTRICT OF TOFINO STANDARDS.



LOCAL ROADS

| | | | | | |
|---|--|----------|----------|---|-----------|
| 3 | | | | | |
| 2 | | | | | |
| 1 | | | TITLE | TYPICAL DRIVEWAY GRADES AT CURBS | |
| | REVISION DATE | APPROVED | | | |
| |  DISTRICT OF TOFINO SUBDIVISION & DEVELOPMENT CONTROL BYLAW | | APPROVED | DRAWING NUMBER R2-SD | |
| | | | DATE | | OCT, 2015 |
| | | | DRAWN BY | | JEA |

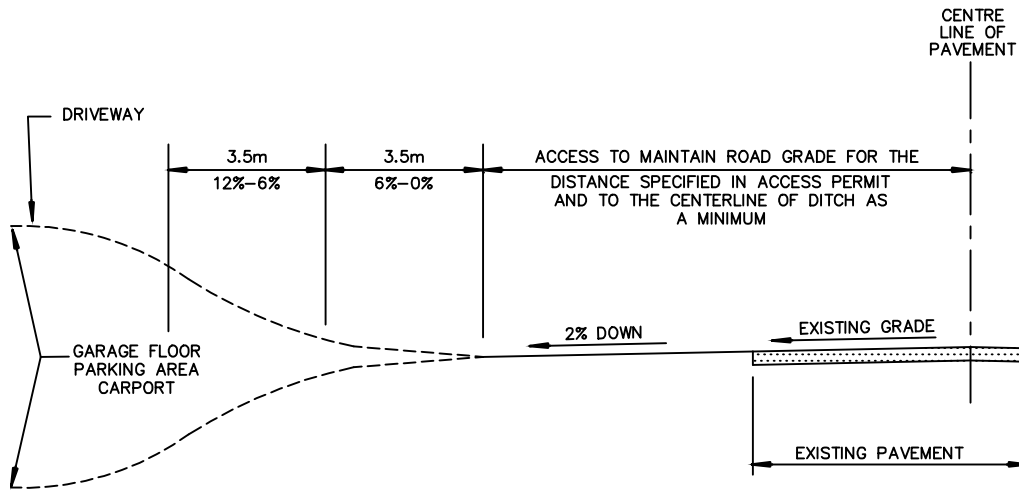

COLLECTOR ROADS

NOTES:

1. THE MAXIMUM GRADE OF THE DRIVEWAY SHALL BE 20% WITH A CHANGE IN RISE OR FALL NOT EXCEEDING 6% (COLLECTOR ONLY) FOR EACH HORIZONTAL 3.5m. THE RISE OR FALL OF THE DRIVEWAY SHALL BEGIN 2.0m BEHIND THE CURB TOWARDS THE PROPERTY.
2. THE SLOPE OF THE EDGES OF THE DRIVEWAY OR FILL SHALL BE A MAXIMUM OF 1 VERTICAL TO 1.5 HORIZONTAL ROCK SLOPES AND CUTS SHALL BE A MAXIMUM OF 4 VERTICAL TO 1 HORIZONTAL.
3. DRIVEWAYS ARE NOT TO EXCEED 6.0 METRES IN WIDTH WITHIN THE STREET.
4. MAXIMUM NUMBER OF DRIVEWAYS PER LOT IS TWO. TOTAL WIDTH FOR THE TWO DRIVEWAYS SHALL NOT EXCEED 6.0 METRES WITHIN THE STREET.
5. DRIVEWAY ACCESS MUST BE LOCATED AT A MINIMUM DISTANCE OF 7 METRES FROM THE INTERSECTION OF ANY 2 ROADS AND 0.75 METRES FROM THE BASE OF ANY BOULEVARD TREE.
6. OWNER/AGENT IS TO SUBMIT A PLAN SHOWING LOCATION AND PROFILE OF DRIVEWAY, BUILDING LOCATION, ELEVATION OF GARAGE/PARKING AREA RELATIVE TO THE BACK OF THE EXISTING CURB AND LOCATION OF EXISTING BOULEVARD PLANTINGS.
7. DRIVEWAY IS TO BE ROUGH GRADED TO PUBLIC WORKS APPROVAL.
8. ALL WATER AND SEWER ACCESSES AND/OR CLEANOUTS WITHIN PROPOSED DRIVEWAY SHALL BE PROTECTED IN ACCORDANCE WITH THE DISTRICT OF TOFINO STANDARDS.

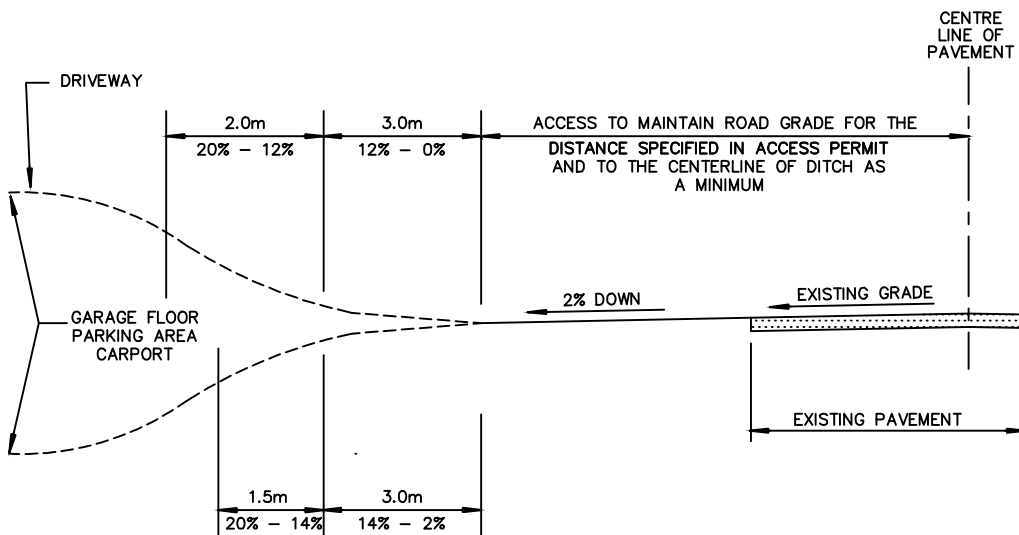

LOCAL ROADS

| | | |
|---------------------------|---|--|
| 3 | | |
| 2 | | |
| 1 | | TITLE TYPICAL DRIVEWAY GRADES AT GRAVEL SHOULDERS |
| | REVISION DATE | APPROVED |
| DISTRICT OF TOFINO | SUBDIVISION & DEVELOPMENT CONTROL BYLAW | |
| | APPROVED | DRAWING NUMBER |
| | DATE | OCT, 2015 |
| | DRAWN BY | JE A |
| | | R3-SD |

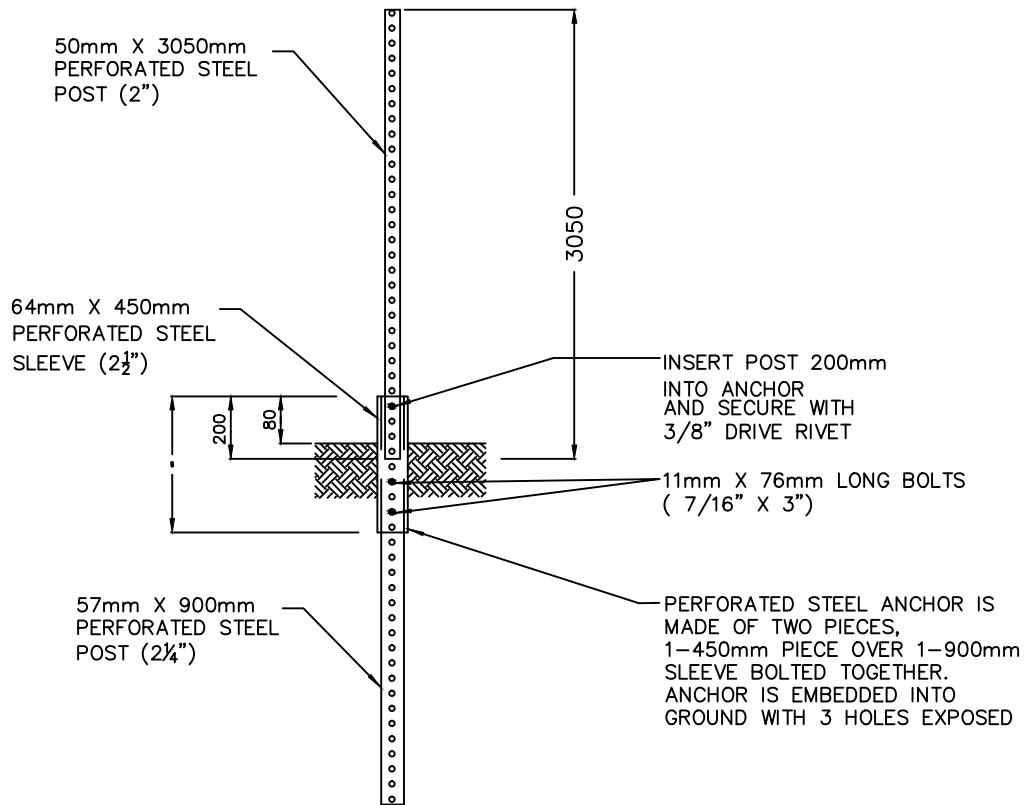

PERFORATED STEEL DOUBLE SLEEVE ANCHOR

FOR PARKING SIGNS, SEE TOFINO PARKING REGULATORY SIGN CRITERIA

| | | | | |
|---|---|---|----------------|--|
| 3 | | DIMENSIONS ARE IN MILLIMETERS UNLESS OTHERWISE NOTED | | |
| 2 | | | | |
| 1 | | | | |
| | REVISION DATE | APPROVED | TITLE | PERFORATED STEEL BASE FOR SIGNS |
|  DISTRICT OF TOFINO | SUBDIVISION & DEVELOPMENT CONTROL BYLAW | | APPROVED | |
| | | | DATE | OCT, 2015 |
| | | | DRAWN BY | JEA |
| | | | DRAWING NUMBER | R4-SD |

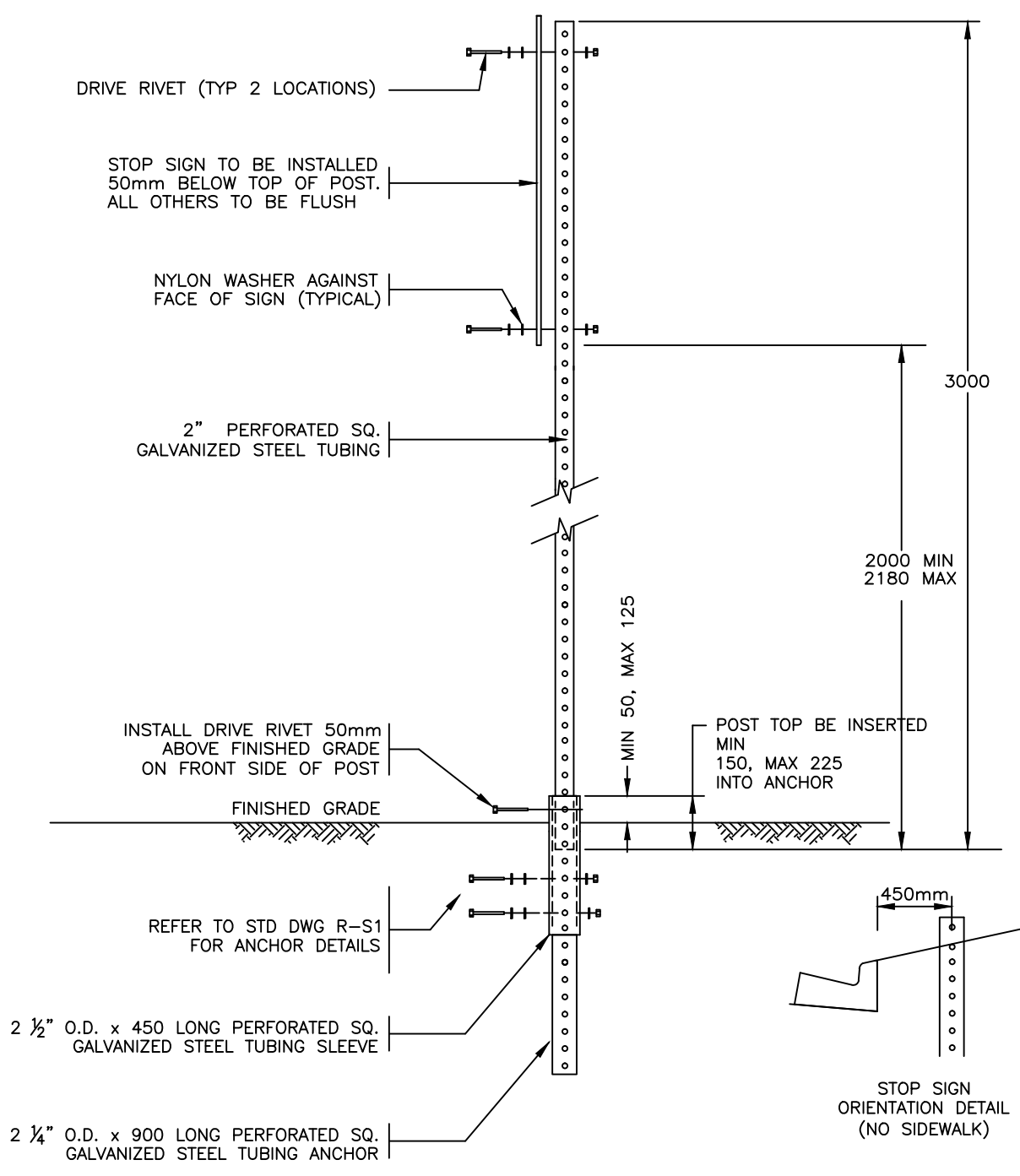

| | |
|---|-----------------------------|
| 3 | |
| 2 | |
| 1 | |
| | REVISION DATE APPROVED |

DIMENSIONS ARE IN MILLIMETERS
UNLESS OTHERWISE NOTED

TITLE **STANDARD TRAFFIC SIGN
INSTALLATION DETAILS**



**DISTRICT OF
TOFINO**

SUBDIVISION &
DEVELOPMENT
CONTROL BYLAW

| | |
|----------|-----------|
| APPROVED | |
| DATE | OCT, 2015 |
| DRAWN BY | JEA |

DRAWING NUMBER
R5-SD

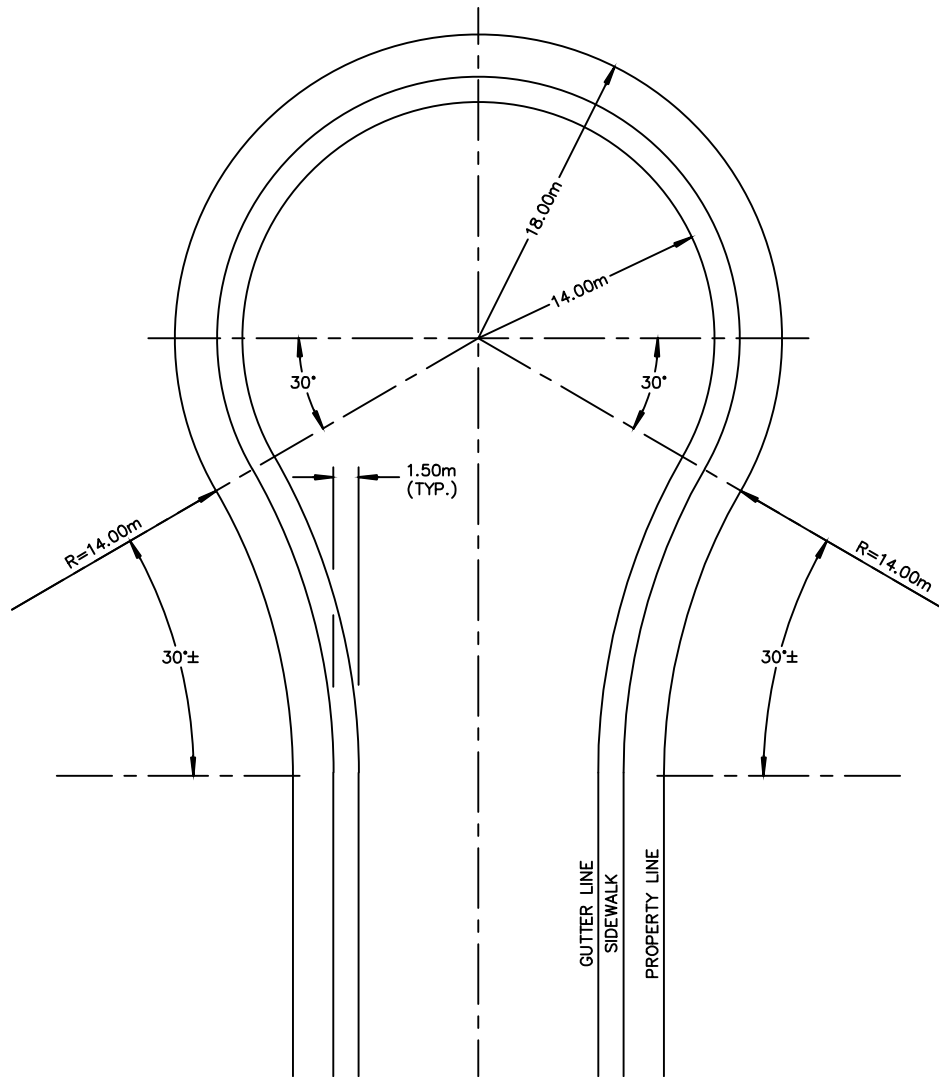

NOTE
 1. WHERE SIDEWALKS ARE REQUIRED
 THEY SHALL BE LOCATED AS SHOWN.

| | | | | |
|---|---------------|----------|----------|--|
| 3 | | | | |
| 2 | | | | |
| 1 | | | TITLE | COMMERCIAL AND INDUSTRIAL STANDARD CUL-DE-SAC |
| | REVISION DATE | APPROVED | APPROVED | DRAWING NUMBER |
| | | | DATE | OCT, 2015 |
| | | | DRAWN BY | JEA |
| | | | | R6-SD |



**DISTRICT OF
TOFINO**

SUBDIVISION &
DEVELOPMENT
CONTROL BYLAW

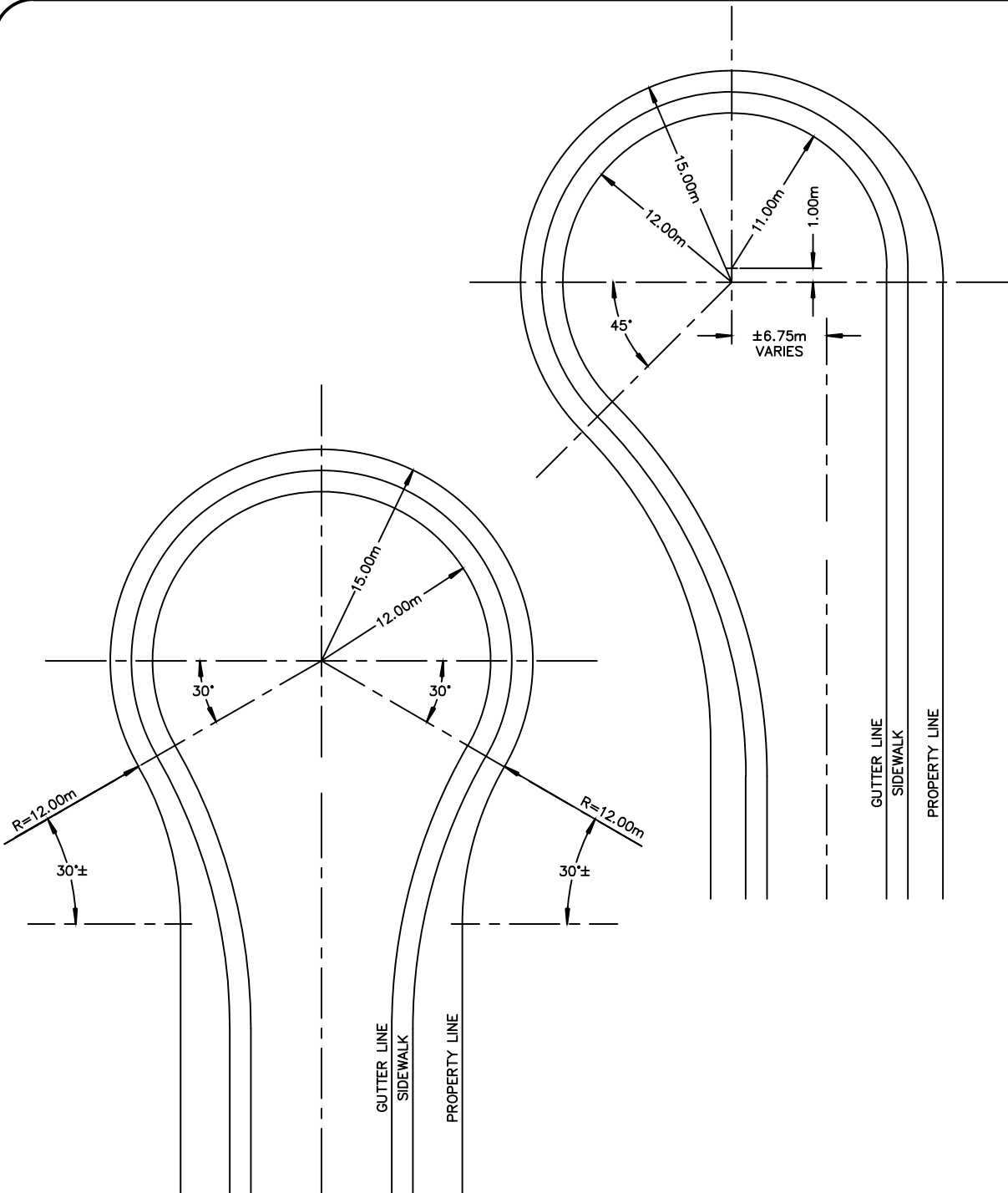

NOTE
 1. WHERE SIDEWALKS ARE REQUIRED
 THEY SHALL BE LOCATED AS SHOWN.

| | | | |
|--|---|---|--|
| 3 | | DIMENSIONS ARE IN MILLIMETERS UNLESS OTHERWISE NOTED | |
| 2 | | | |
| 1 | | | |
| | REVISION DATE | APPROVED | TITLE LOCAL STANDARD AND OFFSET CUL-DE-SACS |
|  DISTRICT OF TOFINO | SUBDIVISION & DEVELOPMENT CONTROL BYLAW | | APPROVED DATE OCT, 2015 DRAWN BY JEA |
| | | | DRAWING NUMBER R7-SD |
| | | | |

Sanitary Sewer and Storm Drain - Drawing Index

| Sanitary Sewer and Storm Drains | | | |
|---------------------------------|--|------------------------------------|--|
| MMCD Standard Detail Drawing | | Tofino Supplemental Detail Drawing | |
| S1 | Standard and Sump Manholes | | Do Not Use |
| | | S1A-SD | Typical Manhole Details for Mains to 375mm diameter – Standard pre-cast type. |
| | | S1B-SD | Typical Manhole Benching Details |
| S2 | Standard Manhole Connection Details | | Use MMCD Drawing Manhole adaptor rings required for plastic pipes. |
| S3 | Manhole Connection Details – Drop and Ramp Type | | Use MMCD Drawing Maximum inside ramp to be reduced from 250mm to 150mm. |
| S4 | Inside Drop Manhole | | Use MMCD Drawing. Maximum 200mm drop for 1200mm manhole. |
| S5 | Precast Riser Manhole | | Use MMCD Drawing. Top manhole riser to be 300mm. |
| S6 | Sewer Cleanout | | Do Not Use |
| | | S6-SD | Temporary Cleanout Structure |
| S7 | Sanitary Sewer Connection | | Use MMCD Drawing Services minimum 0.75 cover. IC riser green for storm drain, white for sanitary sewer. All IC's to be set in in a box per S9, Installation in a driveway and road. |
| S8 | Storm Sewer Service Connection | | Do Not Use Use MMCD S7 and S9 except paint post green, IC riser to be green, lid to be green. |
| S9 | Inspection Chamber for 100mm to 200mm Sanitary Sewer Connections | | Use MMCD Drawing for Sewer and Drain. Concrete box and steel checkerplate lid marked Sanitary or Storm required for all installations per installation in driveway and road. |
| S10 | Inspection Chamber for 250 to 375 Storm Sewer Connection | | Do Not Use Use MMCD S8 and S9 for up to 250mm services. Manholes for over 250mm except where service ties into a close manhole. |
| S11 | Top Inlet Catch Basin | | Do Not Use |
| | | S11A-SD | Curb Type Catch Basin for Formed Curbs Type 1 and Type 2 |

Schedule 'F' - District of Tofino - Supplemental Specifications

Sanitary Sewer and Storm Drain - Drawing Index

| | | | |
|-----|---|---------|--|
| S12 | Lawn Drains | | Use MMCD Drawing |
| S13 | Storm Sewer Inlet With Safety Grillage | | Use MMCD Drawing where appropriate. Install grates at all storm drain inlets and on outlets over 375mm. |
| S14 | Concrete Block Headwall | | Do Not Use |
| | | S14A-SD | Precast Concrete Headwalls for Pipe Inlet and Outlets (300 to 1200). Install grates at all storm drain inlets and on outlets over 375mm. |
| | | S14B-SD | Precast Concrete Headwalls for Pipe Inlets (300 to 450). Install grates at all storm drain inlets and on outlets over 375mm. |
| S15 | Driveway Culverts with Concrete Block Headwalls | | Do Not Use |
| | | S15-SD | Concrete Filled Sandbag Headwall for Culvert Inlets and Outlets. |
| | | S16-SD | Catch Basin Frame and Grate for Type 1 Catch Basins |
| | | S17-SD | Catch Basin Frame and Grate for Type 2 Catch Basins |
| | | S18-SD | Adjustable Catch Basin Frame and Hood for Non Mountable Curbs – Type 3 |
| | | S19-SD | Detail of Storm Service Box and Inspection Assembly Installation in Paved Lanes and High Traffic Areas |
| | | S20-SD | Heavy Duty Manhole Cover and Frame |
| | | S21-SD | Utility Chamber Manhole Frame, Ring and Cover |
| | | S22-SD | Watertight Manhole Frame and Cover |
| | | S23-SD | Standard Plastic Storm Service Box (Special Applications Only) |
| | | S24-SD | Standard Concrete Service Box |
| | | S25-SD | Large Service Box |
| | | S26-SD | MR Type Steel Service Box |
| | | S27-SD | 50mm Pressure Sewer Service |
| | | S28-SD | Sewage Pump Station "Pig Loader" Detail |

Schedule 'F' - District of Tofino - Supplemental Specifications

Sanitary Sewer and Storm Drain - Drawing Index

| | | | |
|--|--|--------|--|
| | | S29-SD | Sewage Pump Station "Pig Loader" Schematic |
| | | S30-SD | Tofino Short Duration Rainfall Intensity – Duration – Frequency Data |
| | | S31-SD | Time of Concentration Table |

HEAVY DUTY MANHOLE FRAME AND COVER

ASPHALT APRON
C/W 50mm BASE
(OFF ROADWAY AREAS)

PRECAST CONCRETE GRADE RINGS
MORTAR INSIDE AND OUT
BUILT TO SUIT GRADE
TWO GRADE RINGS (125 MIN.)
FOUR GRADE RINGS (250 MAX.)

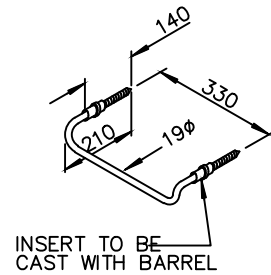
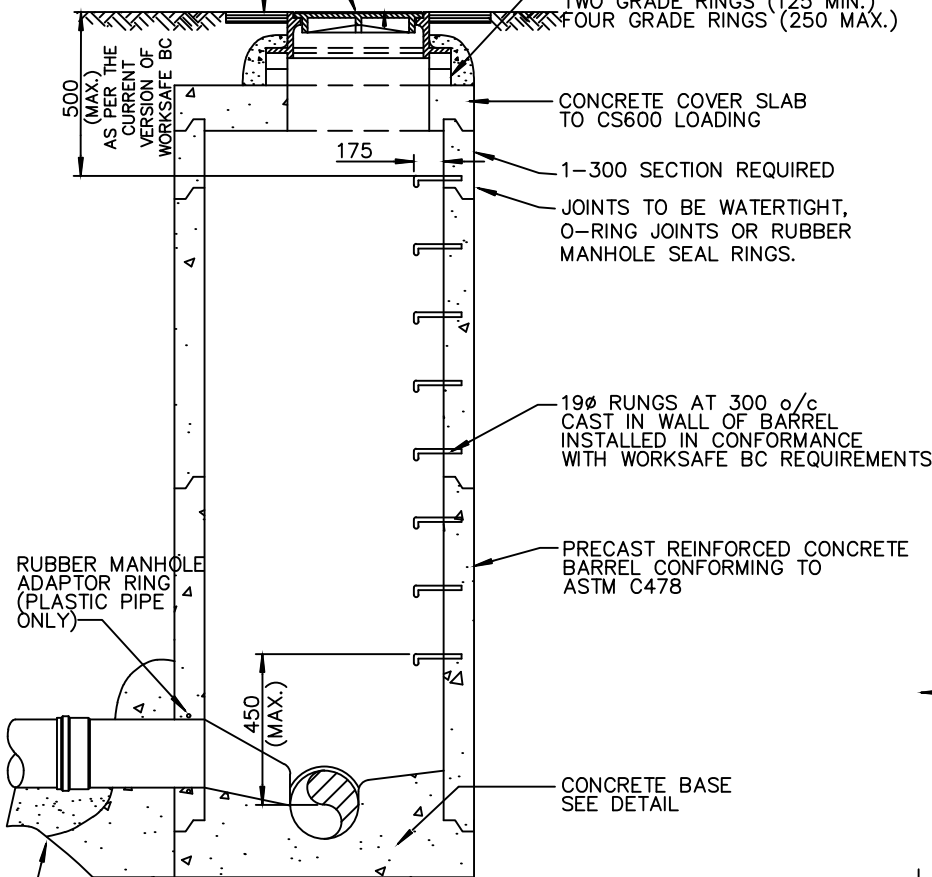

ALUMINUM LADDER RUNG

WHERE MANHOLE BASE EXCAVATION EXTENDS BEYOND BASE DIMENSION, THE OVEREXCAVATION SHALL BE FILLED WITH CONCRETE TO 100 BELOW THE BOTTOM OF THE PIPE AND FOR THE WIDTH OF THE TRENCH

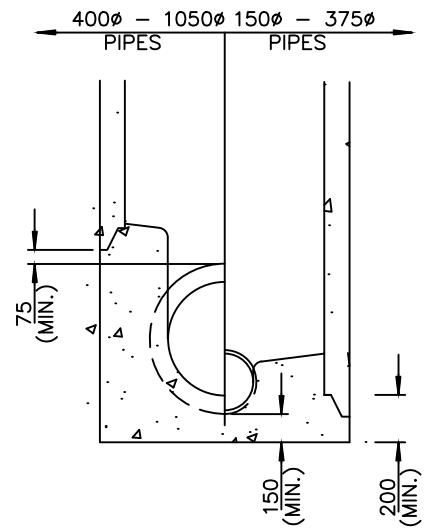

WHERE POSSIBLE USE HALF SECTIONS, OR BREAK OUT TOP HALF OF PIPE

PLASTIC PIPE TO TERMINATE IN MANHOLE WALL WITH RUBBER MANHOLE ADAPTOR RING

CONCRETE BASE DETAIL

| INSIDE PIPE DIA. | INSIDE MANHOLE DIA. |
|------------------|---------------------|
| 450mm AND LESS | 1050 |
| 525 AND 600 | 1200 |
| 675 AND 750 | 1350 |
| 900 AND 1050 | 1500 |
| 1200 AND OVER | RISER MANHOLE |

NOTES:

- MANHOLES LOCATED ON GRAVEL ROADS OR SHOULDERS REQUIRE A 1.5 M X 1.5 M HOT MIX ASPHALT APRON, 50 mm THICK.
- ONLY PRODUCTS APPROVED BY THE SUPERINTENDENT AND LISTED IN THE DISTRICT OF TOFINO APPROVED UTILITY PRODUCTS LIST WILL BE ACCEPTED FOR INSTALLATION.

| | | | |
|--|---------------|---|---|
| 3 | | DIMENSIONS ARE IN MILLIMETERS UNLESS OTHERWISE NOTED | |
| 2 | | | |
| 1 | | | |
| | REVISION DATE | APPROVED | TITLE TYPICAL MANHOLE DETAILS FOR MAINS TO 375mm DIAMETER – STANDARD PRE-CAST TYPE |
|  DISTRICT OF TOFINO SUBDIVISION & DEVELOPMENT CONTROL BYLAW | APPROVED | | DRAWING NUMBER |
| | DATE | OCT, 2015 | S1A-SD |
| | DRAWN BY | JEA | |

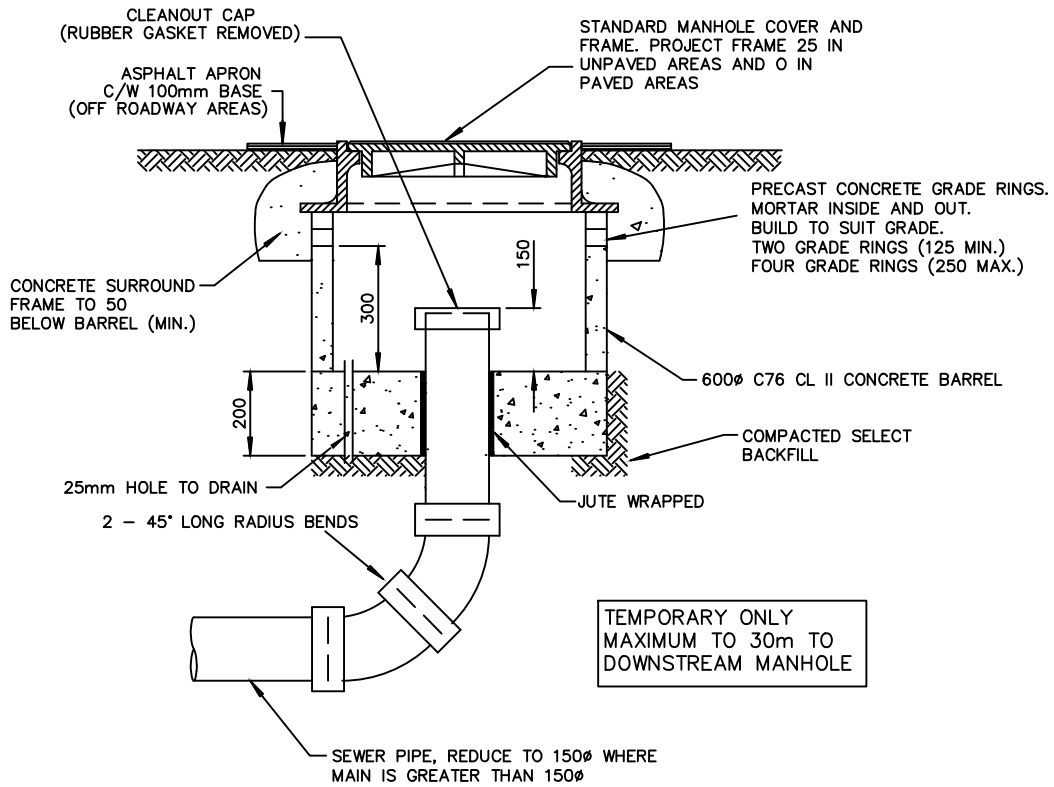

NOTES:

1. TEMPORARY CLEANOUT STRUCTURES MAY ONLY BE USED AT THE DISCRETION OF THE SUPERINTENDENT WHERE THERE IS DEVELOPMENT PHASING.
2. CLEAN OUT STRUCTURES LOCATED ON GRAVEL ROADS OR SHOULDERS REQUIRE A 1.5 m X 1.5 m HOT MIX ASPHALT APRON, 50 mm THICK.
3. ONLY PRODUCTS APPROVED BY THE SUPERINTENDENT AND LISTED IN THE DISTRICT OF TOFINO APPROVED UTILITY PRODUCTS LIST WILL BE ACCEPTED FOR INSTALLATION

| | | | | | |
|---|---|---|--|--------------------------------|-----------|
| 3 | | DIMENSIONS ARE IN MILLIMETERS UNLESS OTHERWISE NOTED | | | |
| 2 | | | | | |
| 1 | | | | | |
| | REVISION DATE | APPROVED | TITLE TEMPORARY CLEANOUT STRUCTURE | | |
|  DISTRICT OF TOFINO | SUBDIVISION & DEVELOPMENT CONTROL BYLAW | | APPROVED | DRAWING NUMBER S6-SD | |
| | | | DATE | | OCT, 2015 |
| | | | DRAWN BY | | JE A |

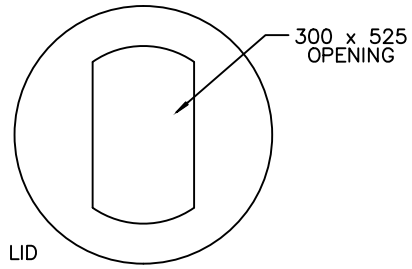
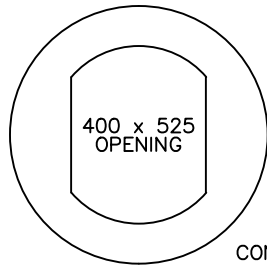

CS600 REINFORCED
CONCRETE CATCH BASIN LID

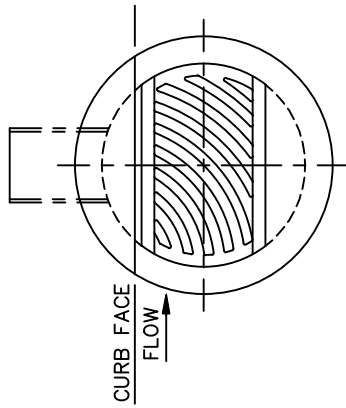

TYPE 1 S16-SD
(NORMALLY, SLOPES UNDER 5%)

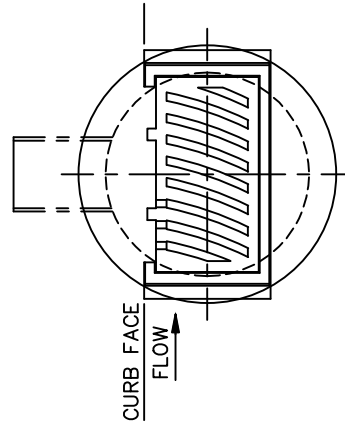

TYPE 2 S17-SD
(NORMALLY, SLOPES OVER 5%)

NOTES:

1. MAX. 3, MIN. 1 PRECAST CONCRETE RISER RINGS LAID IN PORTLAND CEMENT MORTAR.
2. PRECAST CONCRETE LID REINFORCEMENT TO CS600 LOADING.
3. ALL JOINTS TO BE PRE-WETTED BEFORE MORTAR IS PLACED.
4. THE GRATING TO BE PLACED 30mm BELOW FINISHED PAVING IF CURB AND GUTTER IS TO BE CONSTRUCTED, CATCH BASIN CASTINGS ARE TO BE LEFT LOOSE UNTIL AFTER THE CURBING OPERATION HAS BEEN COMPLETED.
5. BASE OF GRANULAR MATERIAL, COMPACTED TO 95% MODIFIED PROCTOR.
6. MORTAR SHALL COMPLY TO A.S.T.M. C-270-68 OR LATEST REVISION.
7. PRECAST REINFORCED CONCRETE SECTIONS SHALL COMFORM TO A.S.T.M. C-478.
8. PRECAST REINFORCED RISER RINGS SHALL COMFORM TO A.S.T.M. C-478.
9. MIN 400mm CLEARANCE TO TRENCH WALL TO ALLOW FOR COMPACTION.
10. OUTLET PIPE TO PROTRUDE 50mm . GROUT LEAD INSIDE AND OUTSIDE.
11. ONLY PRODUCTS APPROVED BY THE SUPERINTENDENT AND LISTED IN THE DISTRICT OF TOFINO APPROVED UTILITY PRODUCTS LIST WILL BE ACCEPTED FOR INSTALLATION.

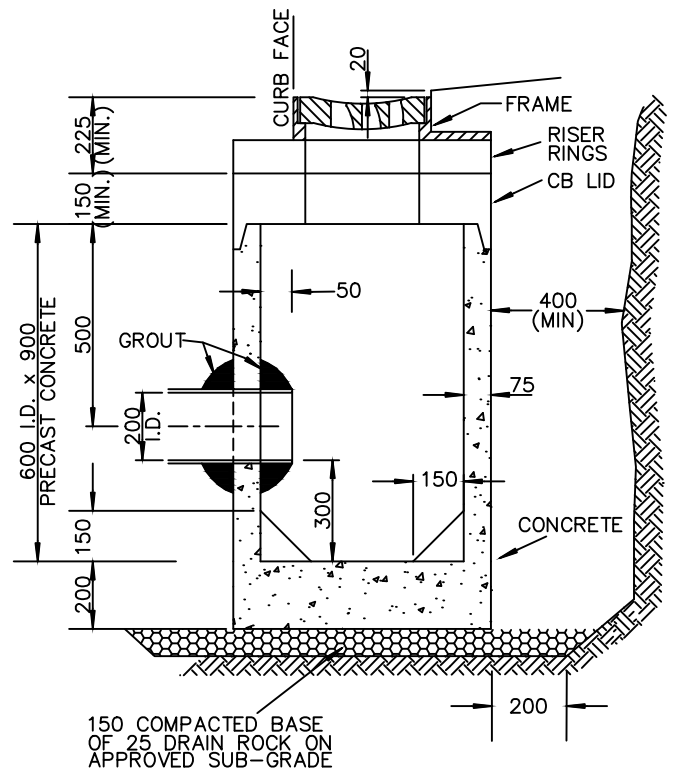

| | | | |
|---|---------------|----------|---|
| 3 | | | DIMENSIONS ARE IN MILLIMETERS UNLESS OTHERWISE NOTED |
| 2 | | | |
| 1 | | | |
| | REVISION DATE | APPROVED | TITLE CURB TYPE CATCH BASIN FOR FORMED CURBS TYPE 1 AND TYPE 2 |
| | | | APPROVED |
| | | | DATE OCT, 2015 |
| | | | DRAWN BY JEA |
| | | | DRAWING NUMBER |
| | | | S11A-SD |



**DISTRICT OF
TOFINO**

SUBDIVISION &
DEVELOPMENT
CONTROL BYLAW

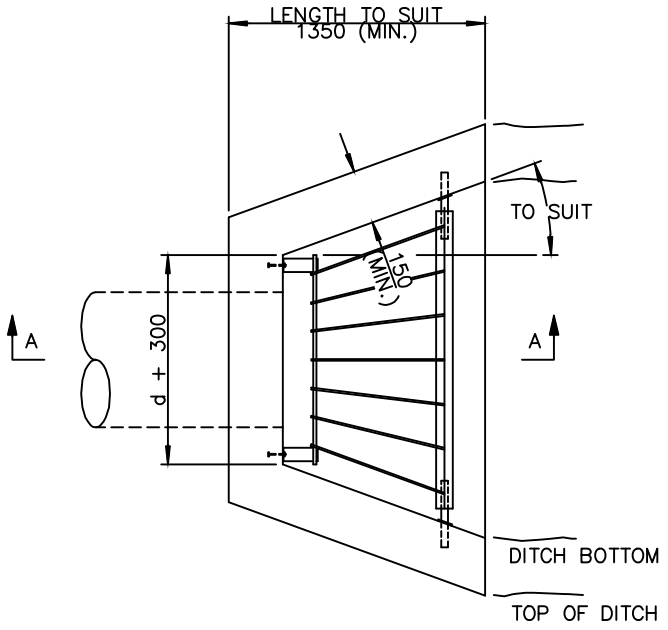

PLAN VIEW

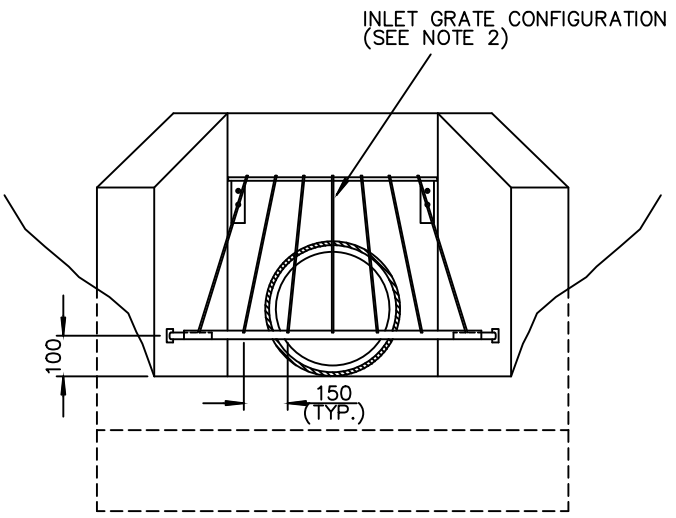

FRONT VIEW

GUARDRAIL WHERE HEIGHT IS OVER 1100mm AND WHERE SPECIFIED IN PLANS

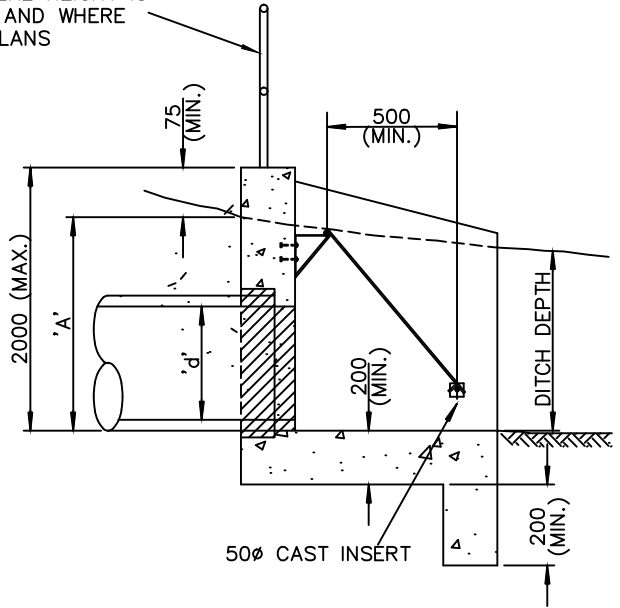

SECTION A-A

- NOTES:
1. THIS DRAWING IS TO BE USED AS A GUIDE ONLY FOR APPROVED PRECAST STRUCTURES. THE DETAILED DESIGN SHALL CONSIDER EXISTING SITE AND SOIL CONDITIONS AND INCLUDE STEEL REINFORCEMENT.
 2. APPROVED GUARDRAIL REQUIRED WHERE 'A' EXCEEDS 1.1m.
 3. STEEL BAR GRILL TO BE 6x40 FLAT BARS OR 20M BARS WELDED TOGETHER.
 4. ALL METAL TO BE HOT-DIP GALVANIZED.
 5. STEEL BAR GRILL TO BE EASILY LIFTED FOR CLEARING DEBRIS.
 6. DELETE GRILL ON OUTLET PIPES LESS THAN 300mm ϕ .
 7. ONLY PRODUCTS APPROVED BY THE SUPERINTENDENT AND LISTED IN THE DISTRICT OF TOFINO APPROVED UTILITY PRODUCTS LIST WILL BE ACCEPTED FOR INSTALLATION.
 9. FOR USE IN PERMANENT AND TEMPORARY INSTALLATIONS.

| | | | | |
|---|---|----------|--|-----------|
| 3 | | | DIMENSIONS ARE IN MILLIMETERS UNLESS OTHERWISE NOTED | |
| 2 | | | TITLE PRECAST CONCRETE HEADWALL FOR PIPE INLETS AND OUTLETS (300ϕ TO 1200ϕ) | |
| 1 | | | | |
| | REVISION DATE | APPROVED | DRAWING NUMBER S14A-SD | |
| |  DISTRICT OF TOFINO | | | |
| | | | | |
| | | | APPROVED | |
| | | | DATE | OCT, 2015 |
| | | | DRAWN BY | JEA |

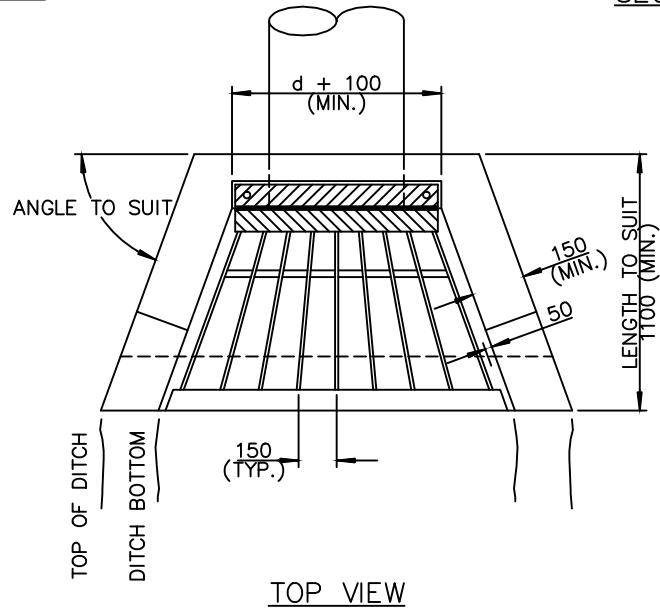
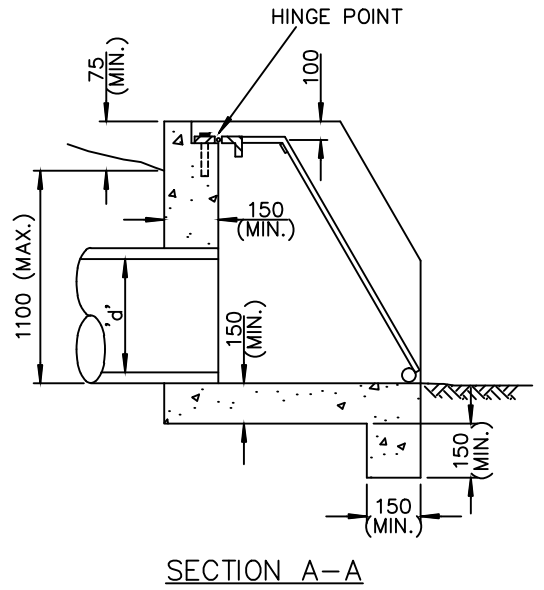
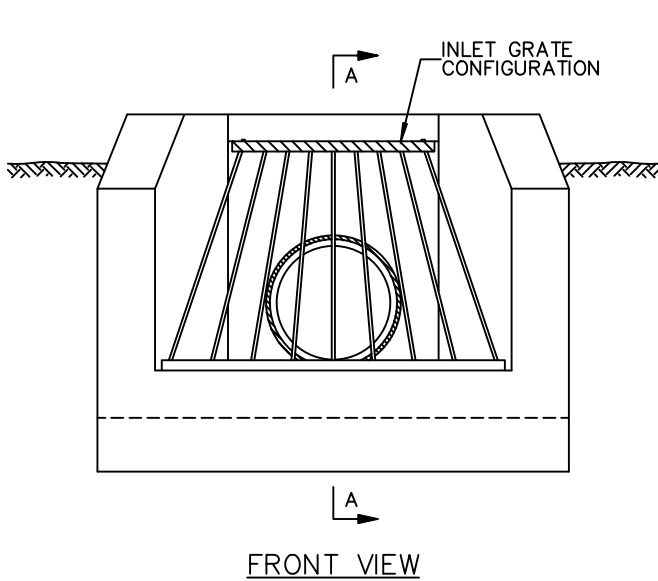

NOTES:

1. THIS DRAWING IS TO BE USED AS A GUIDE ONLY FOR APPROVED PRECAST STRUCTURES. DETAILED DESIGN SHALL CONSIDER EXISTING SITE AND SOIL CONDITIONS AND INCLUDE STEEL REINFORCEMENT.
2. STEEL BAR GRILL TO BE 6x40 FLAT BAR OR 20M BARS WELDED TOGETHER.
3. ALL METAL TO BE HOT-DIP GALVANIZED.
4. STEEL BAR GRILL TO BE EASILY LIFTED FOR CLEARING DEBRIS.
5. ONLY PRODUCTS APPROVED BY THE SUPERINTENDENT AND LISTED IN THE DISTRICT OF TOFINO APPROVED UTILITY PRODUCTS LIST WILL BE ACCEPTED FOR INSTALLATION.

| | | | |
|---------------------------|-----------------------------|---|----------------|
| 3 | | DIMENSIONS ARE IN MILLIMETERS UNLESS OTHERWISE NOTED | |
| 2 | | | |
| 1 | | TITLE PRECAST CONCRETE HEADWALL FOR PIPE INLETS (300Ø TO 450Ø) | |
| | REVISION DATE APPROVED | | |
| DISTRICT OF TOFINO | | SUBDIVISION & DEVELOPMENT CONTROL BYLAW | |
| | | APPROVED | DRAWING NUMBER |
| | | DATE OCT, 2015 | S14B-SD |
| | | DRAWN BY JEA | |

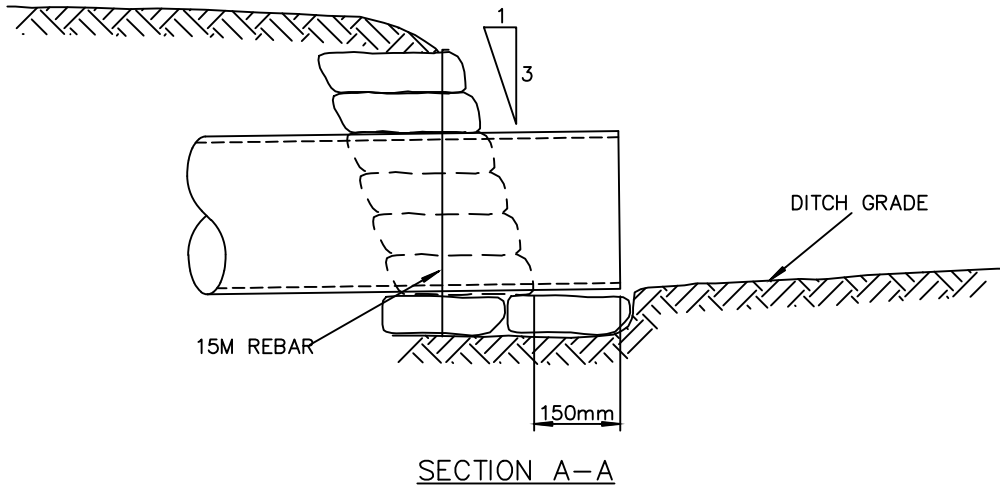

STACKED ROCK HEADWALLS CAN BE USED AS AN ALTERNATIVE

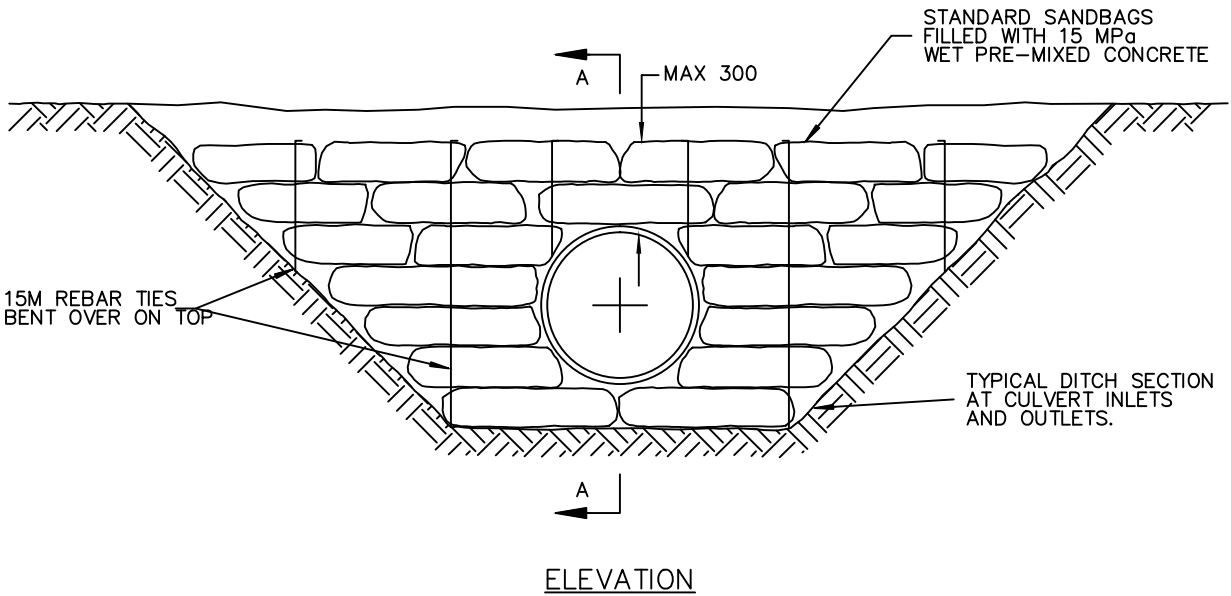

- NOTES
1. IF THE HORIZONTAL DIRECTION OF FLOW AT CULVERT INLETS AND OUTLETS EXCEEDS 30°, THE SANDBAG BULKHEADS REQUIRE CURVED WING WALLS TO FUNNEL THE FLOW.

USE ONLY FOR DRIVEWAY CULVERTS AND HYDRANT ACCESS CROSSINGS UNLESS APPROVED BY THE SUPERINTENDENT.

| | | | | | |
|---|---|---|--|---------------------------------|-----------|
| 3 | | DIMENSIONS ARE IN MILLIMETERS UNLESS OTHERWISE NOTED | | | |
| 2 | | | | | |
| 1 | | | | | |
| | REVISION DATE | APPROVED | TITLE CONCRETE FILLED SANDBAG HEADWALL FOR CULVERT INLETS AND OUTLETS | | |
|  DISTRICT OF TOFINO | SUBDIVISION & DEVELOPMENT CONTROL BYLAW | | APPROVED | DRAWING NUMBER S15-SD | |
| | | | DATE | | OCT, 2015 |
| | | | DRAWN BY | | JEA |

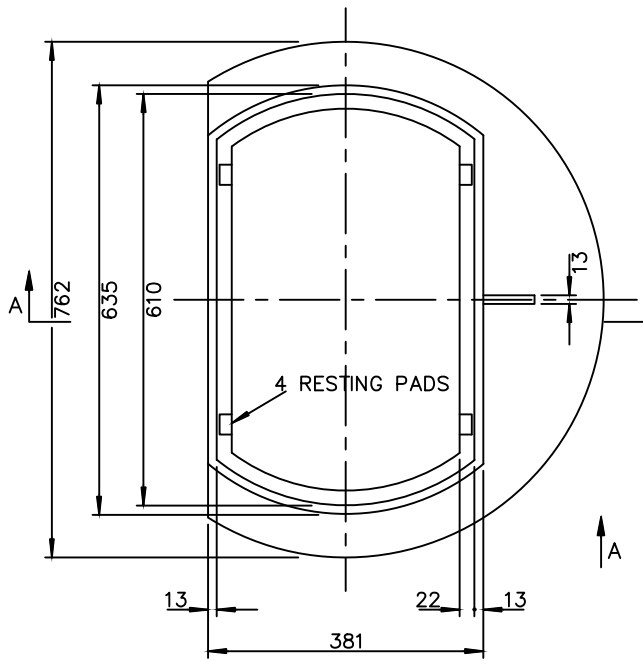

FRAME

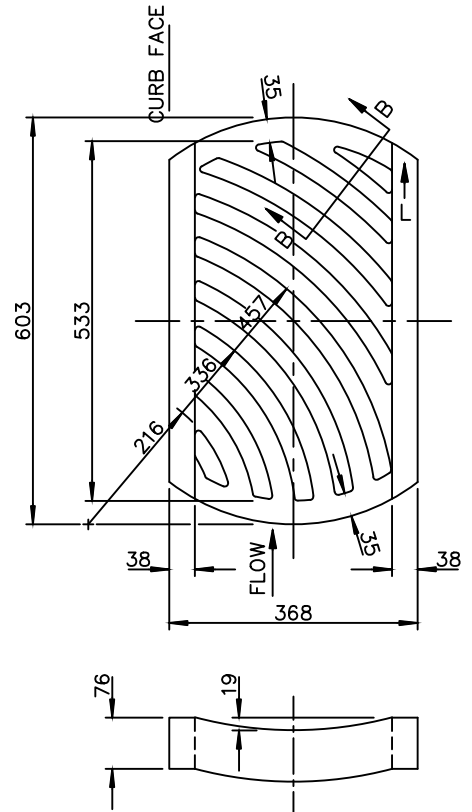

GRATE

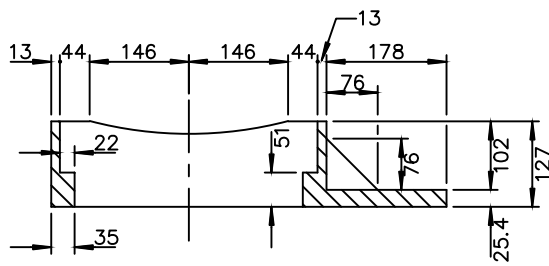

SECTION A-A

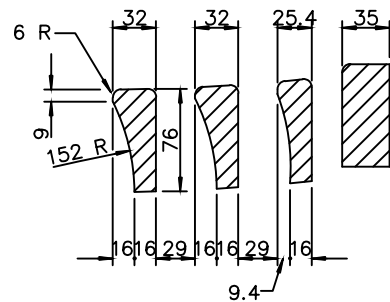

SECTION B-B

NOTES:

1. ALL CASTING SHALL BE CERTIFIED TO MEET CS600 LOADING REQUIREMENTS.
2. APPROXIMATE WEIGHT OF CASTINGS
 FRAME = 59 kg
 GRATE = 61 kg
3. ONLY PRODUCTS APPROVED BY THE SUPERINTENDENT AND LISTED IN THE DISTRICT OF TOFINO APPROVED UTILITY PRODUCTS LIST WILL BE ACCEPTED FOR INSTALLATION.

| | | | | | |
|---|---|---|---|---------------------------------|-----------|
| 3 | | DIMENSIONS ARE IN MILLIMETERS UNLESS OTHERWISE NOTED | | | |
| 2 | | | | | |
| 1 | | | | | |
| | REVISION DATE | APPROVED | TITLE CATCH BASIN FRAME AND GRATE FOR TYPE 1 CATCH BASINS | | |
|  DISTRICT OF TOFINO | SUBDIVISION & DEVELOPMENT CONTROL BYLAW | | APPROVED | DRAWING NUMBER S16-SD | |
| | | | DATE | | OCT, 2015 |
| | | | DRAWN BY | | JEA |

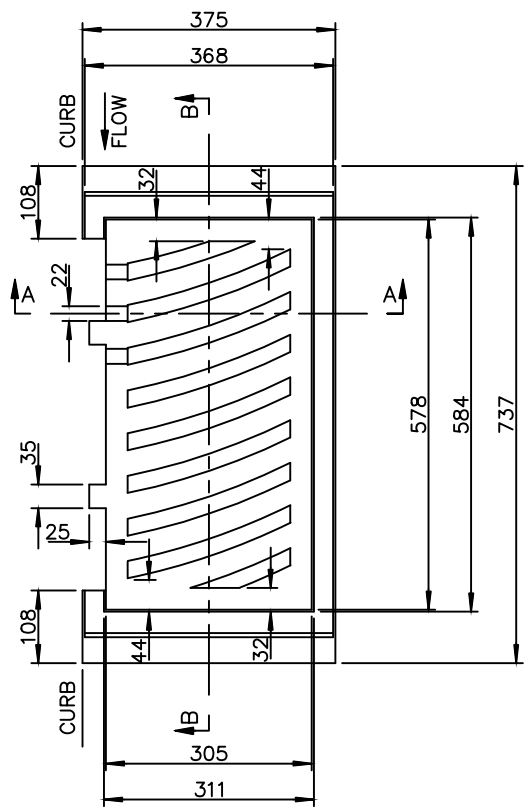

PLAN

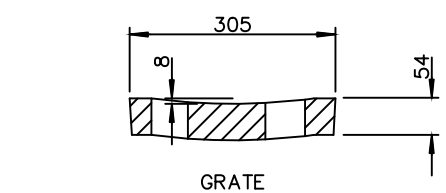

GRATE

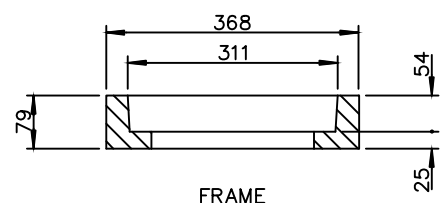

FRAME

SECTION A-A

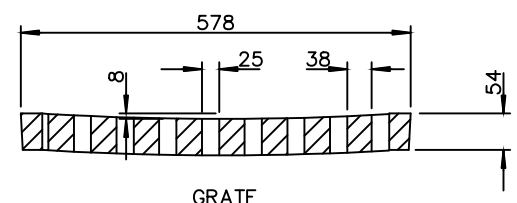

GRATE

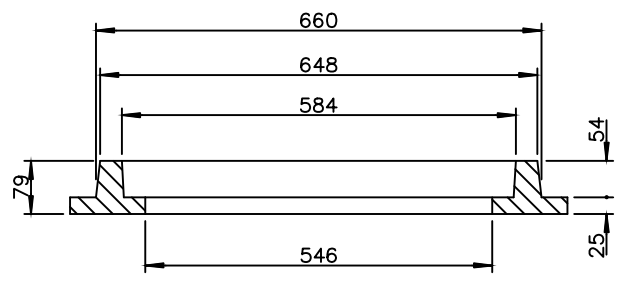

FRAME

SECTION B-B

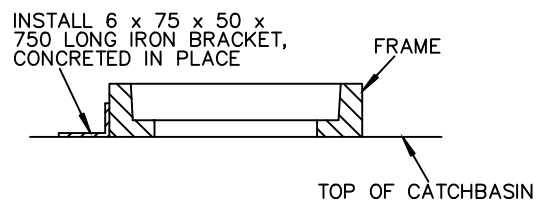

INSTALLATION DETAIL

- NOTES:
1. ALL CASTINGS SHALL BE CERTIFIED TO MEET CS600 LOADING REQUIREMENTS.
 2. APPROXIMATE WEIGHT OF CASTINGS
 FRAME = 36 kg
 GRATE = 39 kg
 3. ONLY PRODUCTS APPROVED BY THE SUPERINTENDENT AND LISTED IN THE DISTRICT OF TOFINO APPROVED UTILITY PRODUCTS LIST WILL BE ACCEPTED FOR INSTALLATION.

| | | | |
|--|---------------|---|---|
| 3 | | DIMENSIONS ARE IN MILLIMETERS UNLESS OTHERWISE NOTED | |
| 2 | | | |
| 1 | | | |
| | REVISION DATE | APPROVED | TITLE CATCH BASIN FRAME AND GRATE FOR TYPE 2 CATCH BASINS |
|  DISTRICT OF TOFINO SUBDIVISION & DEVELOPMENT CONTROL BYLAW | APPROVED | | DRAWING NUMBER S17-SD |
| | DATE | OCT, 2015 | |
| | DRAWN BY | JEA | |

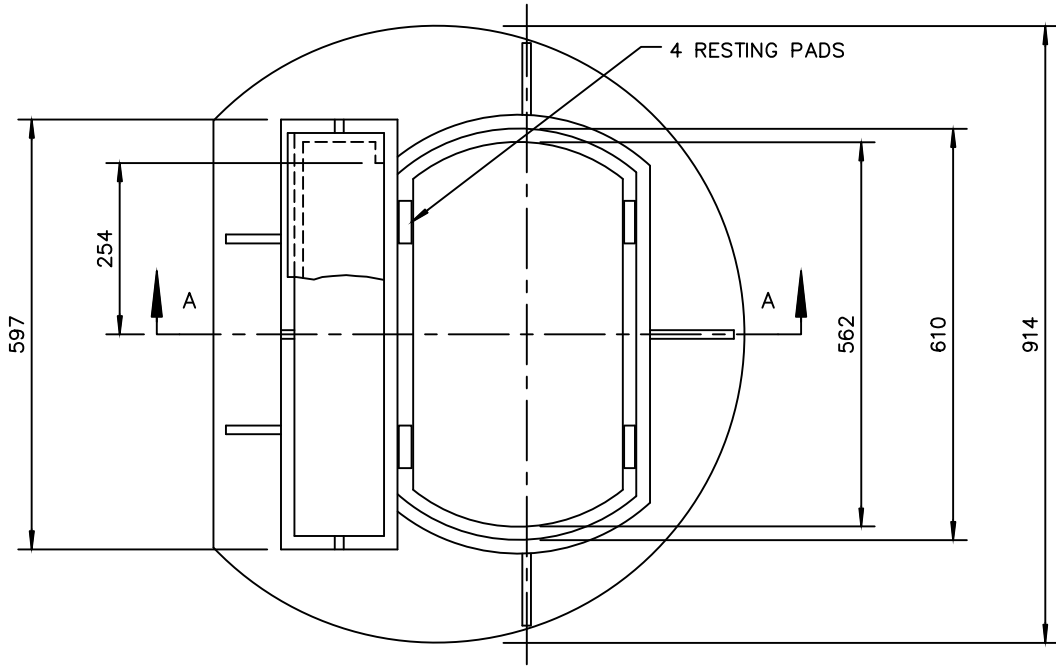

PLAN

750 ϕ CB BARREL AND
250 ϕ LEAD REQUIRED

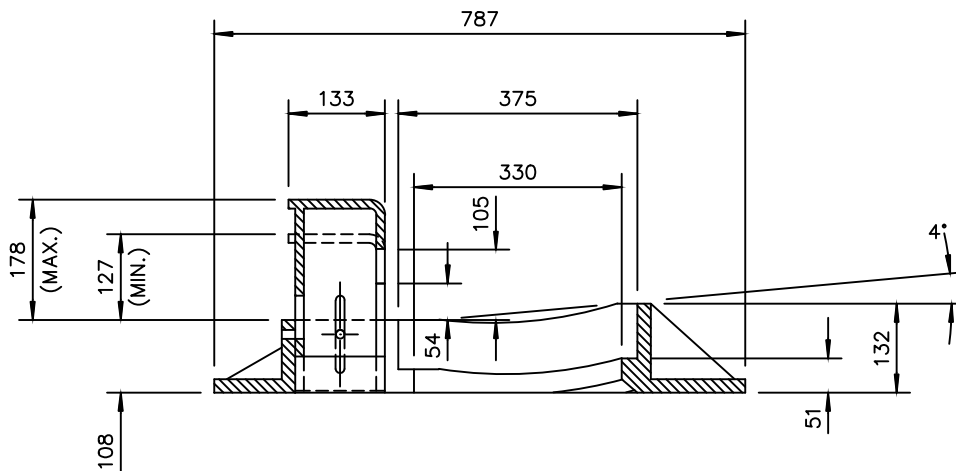

SECTION A-A

NOTES:

1. ALL CASTING SHALL BE CERTIFIED TO MEET CS600 LOADING REQUIREMENTS.
2. FOR GRATE DETAILS SEE STD. DWG ST-9.
3. APPROXIMATE WEIGHT OF CASTINGS
 FRAME = 102 kg
 HOOD = 25 kg
 GRATE = 61 kg
4. ONLY PRODUCTS APPROVED BY THE SUPERINTENDENT AND LISTED IN THE DISTRICT OF TOFINO APPROVED UTILITY PRODUCTS LIST WILL BE ACCEPTED FOR INSTALLATION.

| | | | |
|---|--|---|--|
| 3 | | DIMENSIONS ARE IN MILLIMETERS UNLESS OTHERWISE NOTED | |
| 2 | | TITLE ADJUSTABLE CATCH BASIN FRAME AND HOOD FOR NON MOUNTABLE CURBS – TYPE 3 | |
| 1 | | | |
| | REVISION DATE | APPROVED | |
|  | DISTRICT OF TOFINO SUBDIVISION & DEVELOPMENT CONTROL BYLAW | | APPROVED DATE OCT, 2015 DRAWN BY JEA |
| | | | DRAWING NUMBER |
| | | | S18-SD |

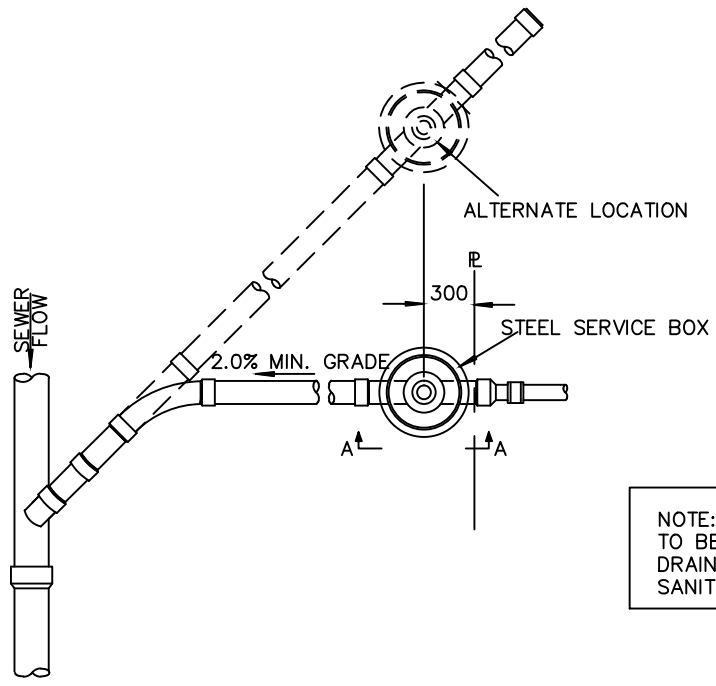

NOTE: RISER PIPE TO BE GREEN FOR DRAIN, WHITE FOR SANITARY SEWER

PLAN

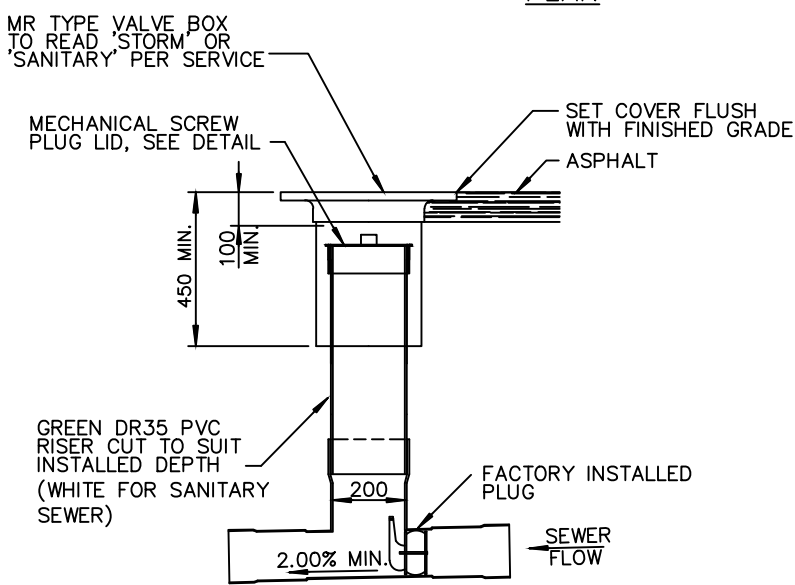

SECTION A-A

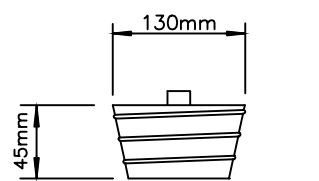

RIGID PLASTIC MECHANICAL SCREW PLUG INSERT

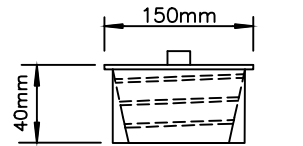

RUBBER SEALING COLLAR

MECHANICAL SCREW PLUG DETAIL

NOTES:

- ONLY PRODUCTS APPROVED BY THE SUPERINTENDENT AND LISTED IN THE DISTRICT OF TOFINO APPROVED UTILITY PRODUCTS LIST WILL BE ACCEPTED FOR INSTALLATION.

| | | |
|---|--|---|
| 3 | | DIMENSIONS ARE IN MILLIMETERS UNLESS OTHERWISE NOTED |
| 2 | | |
| 1 | | |
| REVISION DATE APPROVED | | TITLE SERVICE BOX AND INSPECTION ASSEMBLY INSTALLATION IN PAVED LANES AND HIGH TRAFFIC AREAS |
|  DISTRICT OF TOFINO | | APPROVED DATE OCT, 2015 DRAWN BY JEA |
| SUBDIVISION & DEVELOPMENT CONTROL BYLAW | | DRAWING NUMBER S19-SD |

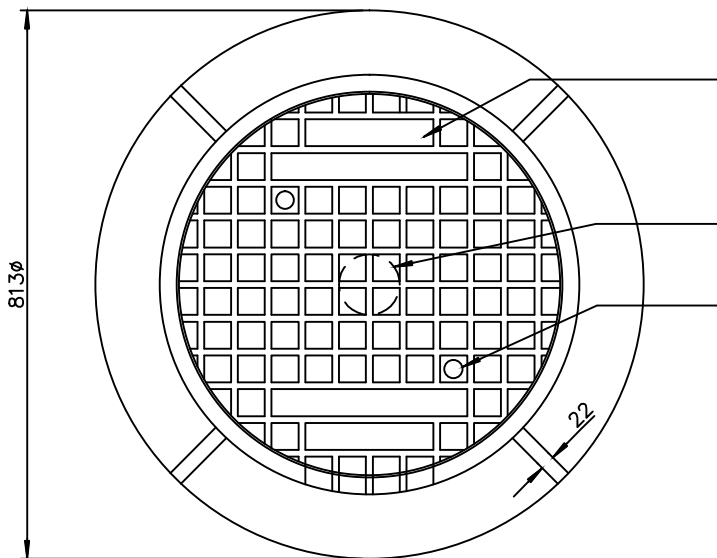

REFERRING TO RELATED UTILITY, LETTERING SHALL BE 25 FLATTENED FACE GOTHIC WITH FACE OF LETTERS RAISED TO THE SAME LEVELS AS THE TOP OF THE RIBS

MANUFACTURES SYMBOL 90 MAXIMUM DIMENSION, CIRCLE OR SQUARE

21 ϕ HOLE FOR CARRIAGE BOLT, TWO REQUIRED AS SHOWN

PLAN

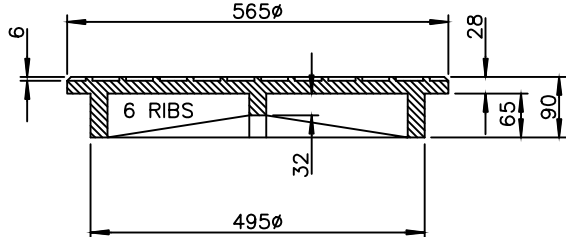

COVER

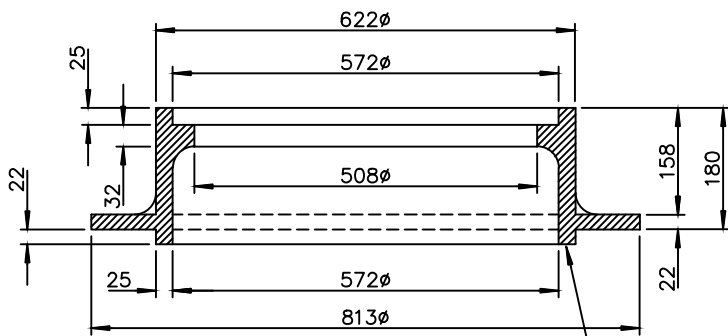

FRAME

FRAMES INSTALLED ON 600 ϕ BARRELS SHALL NOT HAVE RIB

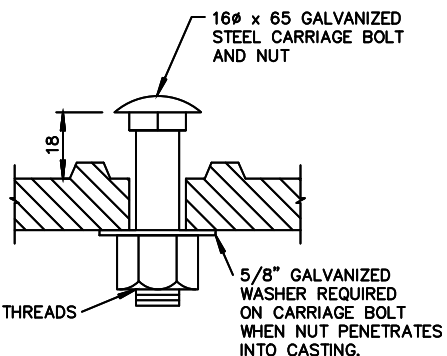

IMPORTANT: CARRIAGE BOLT TO EXTEND EXACTLY 18mm ABOVE CASTING.

CARRIAGE BOLT DETAIL

NOTES:

1. ALL CASTINGS SHALL BE CERTIFIED TO MEET CS600 REQUIREMENTS
2. ALL METAL BEARING SURFACES BETWEEN FRAME, COVER AND RISER RINGS MACHINED FOR NON ROCKING FIT IN ALL POSITIONS. ALLOW 1.5 RAISED FACE IN CASTING FOR MACHINING
3. ONLY PRODUCTS APPROVED BY THE SUPERINTENDENT AND LISTED IN THE DISTRICT OF TOFINO APPROVED UTILITY PRODUCTS LIST WILL BE ACCEPTED FOR INSTALLATION.

| | | | | | |
|---|---------------|----------|----------|---|----------------|
| 3 | | | | | |
| 2 | | | | | |
| 1 | | | | | |
| | REVISION DATE | APPROVED | TITLE | HEAVY DUTY MANHOLE COVER AND FRAME | |
| | | | APPROVED | | DRAWING NUMBER |
| | | | DATE | OCT, 2015 | S20-SD |
| | | | DRAWN BY | JEA | |



DISTRICT OF TOFINO

SUBDIVISION & DEVELOPMENT CONTROL BYLAW

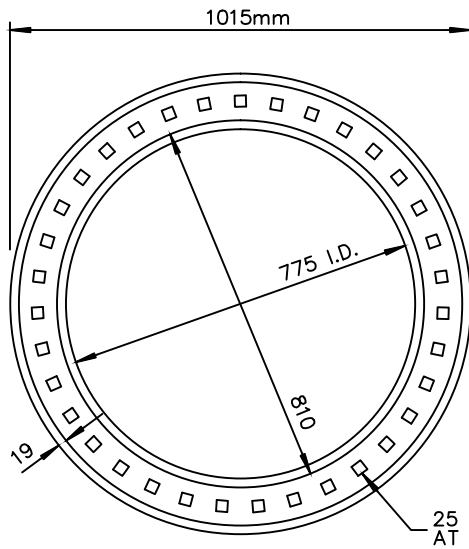

PLAN OF FRAME

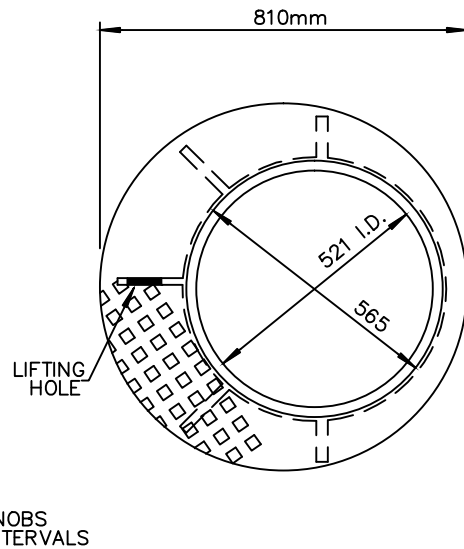

PLAN OF OUTER RING

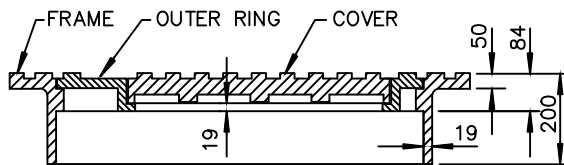

SECTION OF FRAME, RING AND COVER

MANHOLE COVERS TO BE LABELED REFERING TO RELATED UTILITY

NOTES:

1. THIS MANHOLE FRAME AND COVER IS TO BE USED FOR ACCESS TO UNDERGROUND UTILITY CHAMBERS.
2. ALL CASTINGS SHALL BE CERTIFIED TO MEET CS600 LOADING REQUIREMENTS.
3. ONLY PRODUCTS APPROVED BY THE SUPERINTENDENT AND LISTED IN THE DISTRICT OF TOFINO APPROVED UTILITY PRODUCTS LIST WILL BE ACCEPTED FOR INSTALLATION

| | | | | | |
|---|---|---|--|---------------------------------|-----------|
| 3 | | DIMENSIONS ARE IN MILLIMETERS UNLESS OTHERWISE NOTED | | | |
| 2 | | | | | |
| 1 | | | | | |
| | REVISION DATE | APPROVED | TITLE UTILITY CHAMBER MANHOLE FRAME, RING, AND COVER | | |
|  DISTRICT OF TOFINO | SUBDIVISION & DEVELOPMENT CONTROL BYLAW | | APPROVED | DRAWING NUMBER S21-SD | |
| | | | DATE | | OCT, 2015 |
| | | | DRAWN BY | | JEA |

APPLICATION: UNITS ARE FOR USE IN AREAS WHERE FLOODING OR HIGH TIDES ARE POSSIBLE. THIS UNIT SHALL HAVE A POSITIONING LUG IN COVER FOR EASY REPLACEMENT OF CAP SCREWS AND SHALL BE EQUIPPED WITH FOUR ONLY 19Ø HOLES IN FRAME FOR ANCHOR BOLTS AS SHOWN.

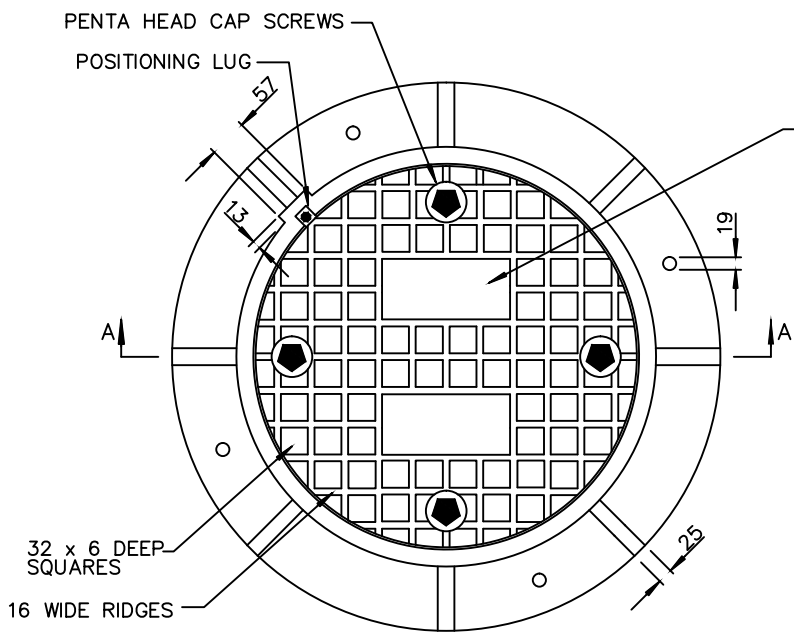

LETTERING REFERING TO UTILITY TYPE, LETTERING SHALL BE 25 FLATTENED FACE GOTHIC WITH FACE OF LETTERS RAISED TO THE SAME LEVELS AS THE TOP OF THE RIBS

WEIGHT OF UNIT SHOWN IS
 FRAME = 113.4 kg
 COVER = 56.7 kg

- FURNISHED WITH:
- A) FOUR 13x57 PENTA HEAD STAINLESS STEEL CAP SCREWS TO DISCOURAGE VANDALISM.
 - B) A 6mm THICK NEOPRENE GASKET FULLY ENCOMPASSING BOLT HOLES.
 - C) METAL SURFACES BETWEEN FRAME AND COVER MACHINED TO ENSURE NON ROCKING FIT IN ALL POSITIONS. ALLOW 1.5 RAISED FACE IN CASTING FOR MACHINING.
 - D) MANUFACTURE BOLT HOLES TO PERMIT INTERCHANGING OF COVERS BETWEEN FRAME UNITS.

PLAN

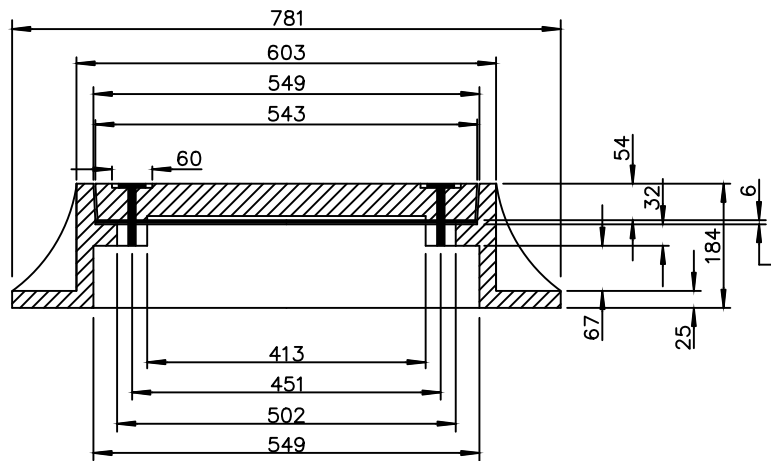

NEOPRENE GASKET

DIA. OF COVER ----- 543
 THICKNESS OF COVER -- 54
 DIA. OF FRAME ----- 781
 DEPTH OF FRAME ----- 184

SECTION A-A

NOTES:

1. ALL CASTINGS SHALL BE CERTIFIED TO MEET CS600 LOADING REQUIREMENTS.
2. FRAME SHALL BE SET IN MORTAR AND BOLTED TO THE MANHOLE SLAB WITH 19Ø STAINLESS STEEL BOLTS, WASHERS AND NUTS.
3. ONLY PRODUCTS APPROVED BY THE SUPERINTENDENT AND LISTED IN THE DISTRICT OF TOFINO APPROVED UTILITY PRODUCTS LIST WILL BE ACCEPTED FOR INSTALLATION.

| | | | | | |
|---------------------------|---------------|---|---|---|----------------|
| 3 | | DIMENSIONS ARE IN MILLIMETERS UNLESS OTHERWISE NOTED | | | |
| 2 | | | | | |
| 1 | | | | | |
| | REVISION DATE | APPROVED | TITLE | WATERTIGHT MANHOLE FRAME AND COVER | |
| | | | APPROVED | | |
| | | | DATE | OCT, 2015 | |
| | | | DRAWN BY | JE A | |
| DISTRICT OF TOFINO | | | SUBDIVISION & DEVELOPMENT CONTROL BYLAW | | DRAWING NUMBER |
| | | | | | S22-SD |

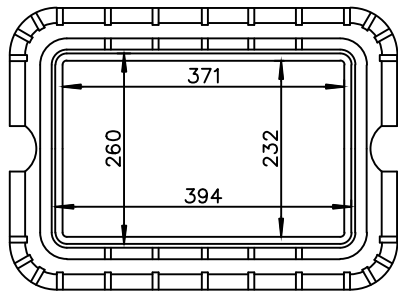

PLAN

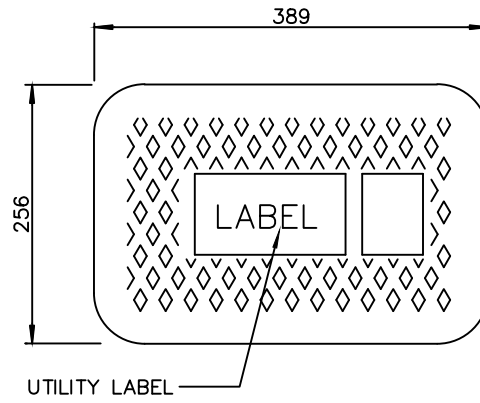

COVER

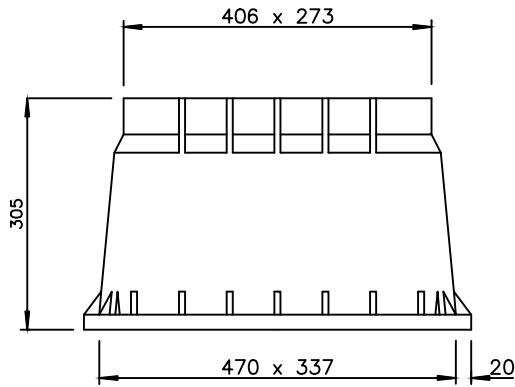

STANDARD SERVICE BOX
ELEVATION

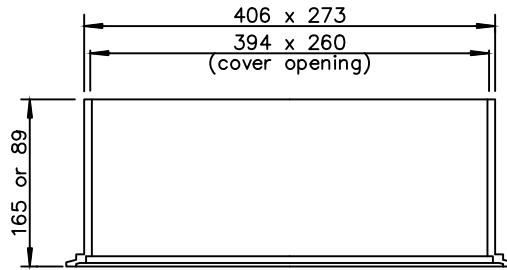

SERVICE BOX EXTENSION

NOTES:

1. MARK LID WITH RELATED UTILITY
2. PLASTIC SERVICE BOXES SHALL BE USED IN EXISTING LANDSCAPE AREAS. APPLICATIONS MUST HAVE APPROVAL FROM SUPERINTENDENT.
3. ONLY PRODUCTS APPROVED BY THE SUPERINTENDENT AND LISTED IN THE DISTRICT OF TOFINO APPROVED UTILITY PRODUCTS LIST WILL BE ACCEPTED FOR INSTALLATION.

| | | | |
|---|---|--|----------------|
| 3 | | DIMENSIONS ARE IN MILLIMETERS UNLESS OTHERWISE NOTED | |
| 2 | | TITLE STANDARD PLASTIC SERVICE BOX (SPECIAL APPLICATIONS ONLY) | |
| 1 | | | |
| | REVISION DATE APPROVED | APPROVED | DRAWING NUMBER |
| | | DATE OCT, 2015 | S23-SD |
| | | DRAWN BY JEA | |



**DISTRICT OF
TOFINO**

SUBDIVISION &
DEVELOPMENT
CONTROL BYLAW

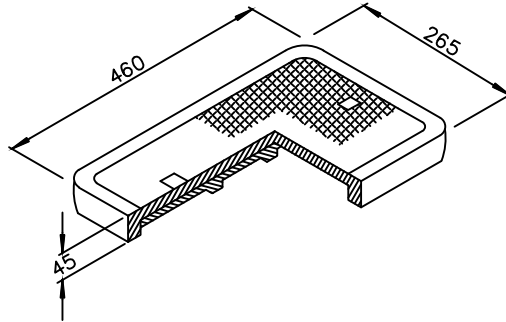

CAST IRON TRAFFIC COVER
LID TO READ UTILITY TYPE

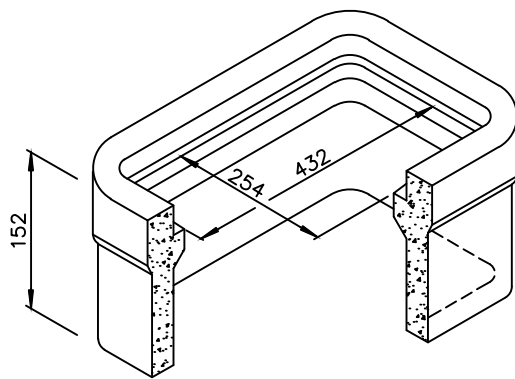

TOP

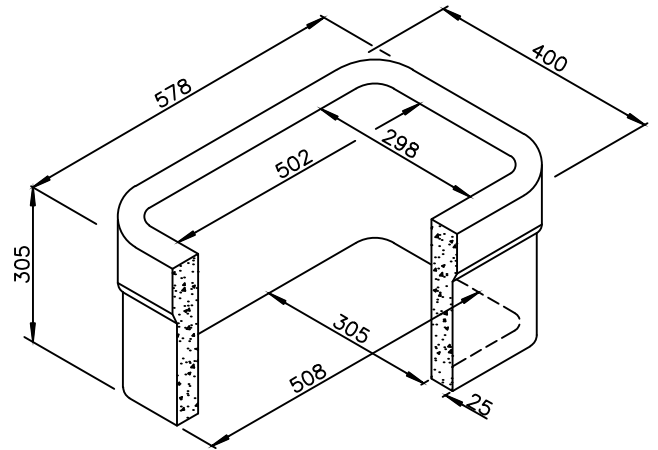

BOTTOM

NOTES

1. MARK LID WITH RELATED UTILITY LABEL
2. ONLY PRODUCTS APPROVED BY THE SUPERINTENDENT AND LISTED IN THE DISTRICT OF TOFINO APPROVED UTILITY PRODUCTS LIST WILL BE ACCEPTED FOR INSTALLATION.

| | | | |
|---|---|---|---------------------------------|
| 3 | | DIMENSIONS ARE IN MILLIMETERS UNLESS OTHERWISE NOTED | |
| 2 | | | |
| 1 | | | |
| | REVISION DATE APPROVED | TITLE STANDARD CONCRETE SERVICE BOX | |
|  DISTRICT OF TOFINO | SUBDIVISION & DEVELOPMENT CONTROL BYLAW | APPROVED | DRAWING NUMBER S24-SD |
| | | DATE OCT, 2015 | |
| | | DRAWN BY JEA | |

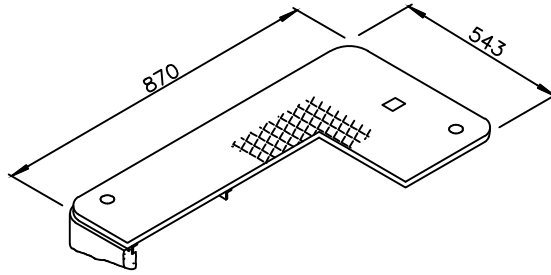

STEEL TRAFFIC COVER
LID TO READ SANITARY
OR STORM OR WATER
FOR RELATED UTILITY

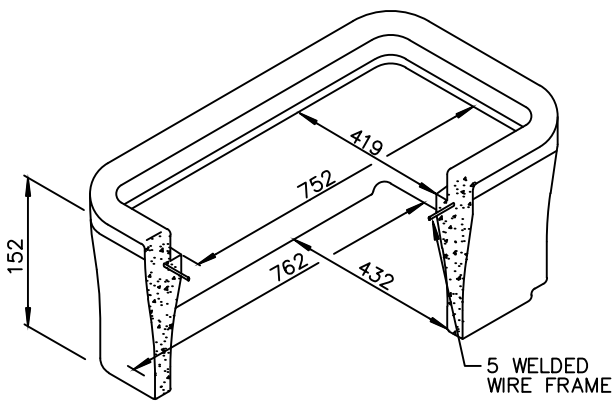

TOP

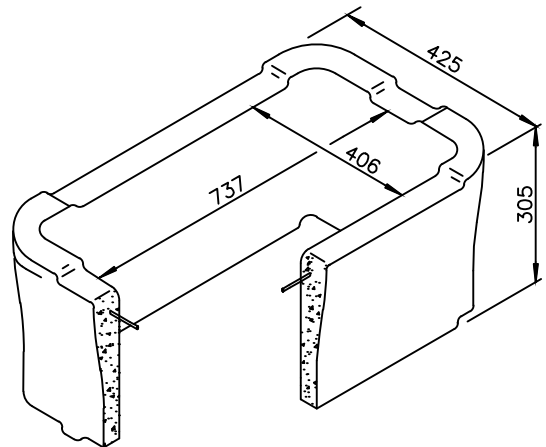

BOTTOM

NOTES

1. MARK LID WITH RELATED UTILITY LABEL
2. ONLY PRODUCTS APPROVED BY THE SUPERINTENDENT AND LISTED IN THE DISTRICT OF TOFINO APPROVED UTILITY PRODUCTS LIST WILL BE ACCEPTED FOR INSTALLATION.

| | | | |
|---|---------------------------|---|---|
| 3 | | DIMENSIONS ARE IN MILLIMETERS UNLESS OTHERWISE NOTED | |
| 2 | | TITLE LARGE SERVICE BOX | |
| 1 | | | |
| | REVISION DATE | APPROVED | |
|  | DISTRICT OF TOFINO | | SUBDIVISION & DEVELOPMENT CONTROL BYLAW |
| | APPROVED | | DRAWING NUMBER |
| | DATE | OCT, 2015 | S25-SD |
| DRAWN BY | JEA | | |

3mm RAISED SINGLE DIAMOND CHECKER PLATE FLANGE

PARSONS LONG NECK LID C/W WORD RELATED TO UTILITY STAMPED IN 20mm HIGH LETTERING FOR IDENTIFICATION

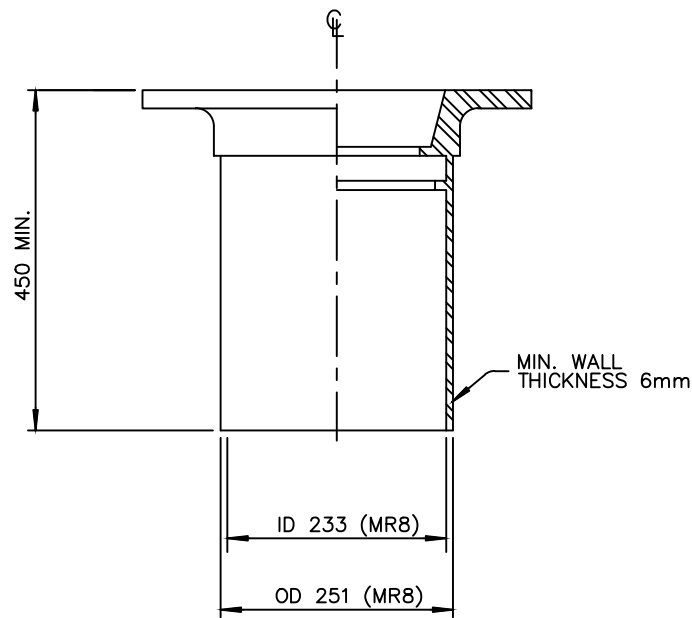
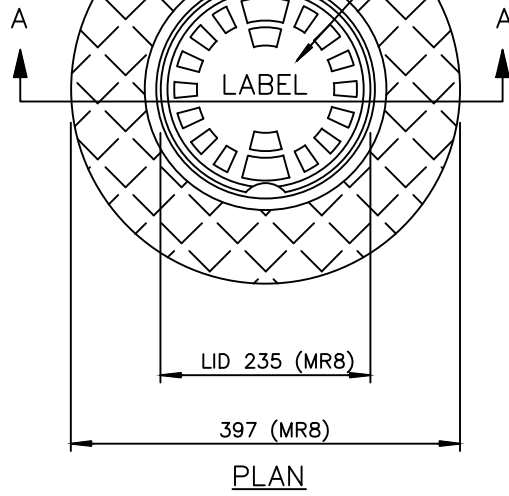

NOTES:

1. FINISH COATING TO BE BITUMINOUS DIP.
2. ONLY PRODUCTS APPROVED BY THE SUPERINTENDENT AND LISTED IN THE DISTRICT OF TOFINO APPROVED UTILITY PRODUCTS LIST WILL BE ACCEPTED FOR INSTALLATION.

| | | |
|---|--|---|
| 3 | | DIMENSIONS ARE IN MILLIMETERS UNLESS OTHERWISE NOTED |
| 2 | | |
| 1 | | TITLE MR TYPE STEEL SERVICE BOX |
| | REVISION DATE APPROVED | APPROVED |
| | DISTRICT OF TOFINO SUBDIVISION & DEVELOPMENT CONTROL BYLAW | DATE OCT, 2015 |
| | | DRAWN BY JEA |
| | | DRAWING NUMBER S26-SD |

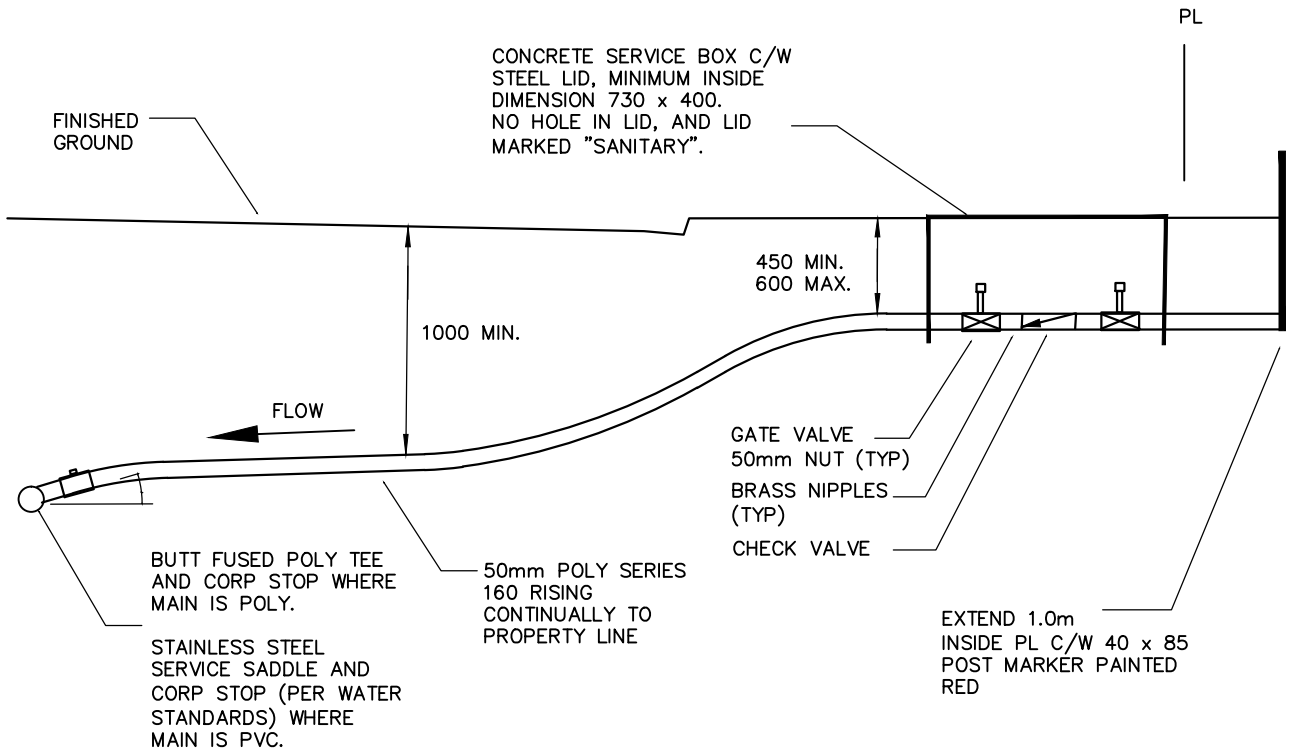

NOTES:

1. ONLY PRODUCTS APPROVED BY THE SUPERINTENDENT AND LISTED IN THE DISTRICT OF TOFINO APPROVED UTILITY PRODUCTS LIST WILL BE ACCEPTED FOR INSTALLATION.
2. MINIMUM SIZE FOR PRESSURE SEWER SERVICE IS 50mm
3. STAINLESS STEEL INSERTS REQUIRED AT ALL SERVICE CONNECTION JOINTS.

| | | | |
|---|---|---|---------------------------------|
| 3 | | DIMENSIONS ARE IN MILLIMETERS UNLESS OTHERWISE NOTED | |
| 2 | | | |
| 1 | | | |
| | REVISION DATE APPROVED | TITLE 50mm PRESSURE SEWER SERVICE | |
|  DISTRICT OF TOFINO | SUBDIVISION & DEVELOPMENT CONTROL BYLAW | APPROVED | DRAWING NUMBER S27-SD |
| | | DATE OCT, 2015 | |
| | | DRAWN BY JEA | |

MATERIALS

- ① 50 THICK HIGH DENSITY STYROFOAM INSULATION
- ② 65Ø FIRE HOSE CONNECTION AND CAP (BRASS)
- ③ 65Ø STAINLESS STEEL BALL VALVE
- ④ 12Ø STAINLESS STEEL BALL VALVE c/w 12 x 50 NIPPLE (S.S.)
- ⑤ 100 x 63 REDUCING SPOOL c/w 12 T.O.L.
- ⑥ COUPLING
- ⑦ 100Ø SPOOL
- ⑧ 100Ø 90° ELBOW (LONG RADIUS)
- ⑨ 100Ø FORCE MAIN

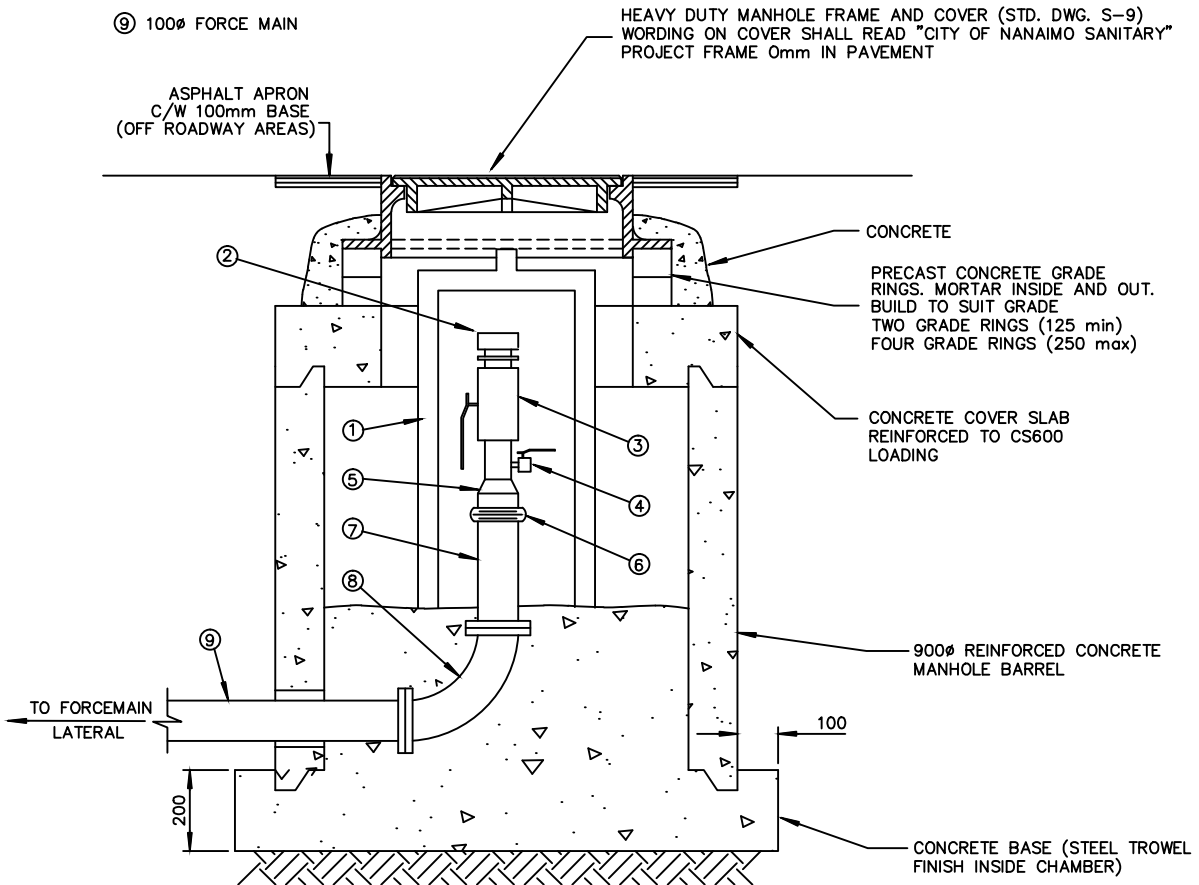

NOTES:

- 1. STRUCTURES LOCATED ON GRAVEL ROADS OR SHOULDERS REQUIRE A 1.5 m X 1.5 m HOT MIX ASPHALT APRON, 50 mm THICK
- 2. ONLY PRODUCTS APPROVED BY THE SUPERINTENDENT AND LISTED IN THE DISTRICT OF TOFINO APPROVED UTILITY PRODUCTS LIST WILL BE ACCEPTED FOR INSTALLATION.

| | | | |
|---|---|--|-----------|
| 3 | | DIMENSIONS ARE IN MILLIMETERS UNLESS OTHERWISE NOTED | |
| 2 | | | |
| 1 | | TITLE SEWAGE PUMP STATION "PIG LOADER" DETAIL | |
| | REVISION DATE | APPROVED | |
|  DISTRICT OF TOFINO | SUBDIVISION & DEVELOPMENT CONTROL BYLAW | APPROVED | |
| | | DATE | OCT, 2015 |
| | | DRAWN BY | JEA |
| | | DRAWING NUMBER S28-SD | |

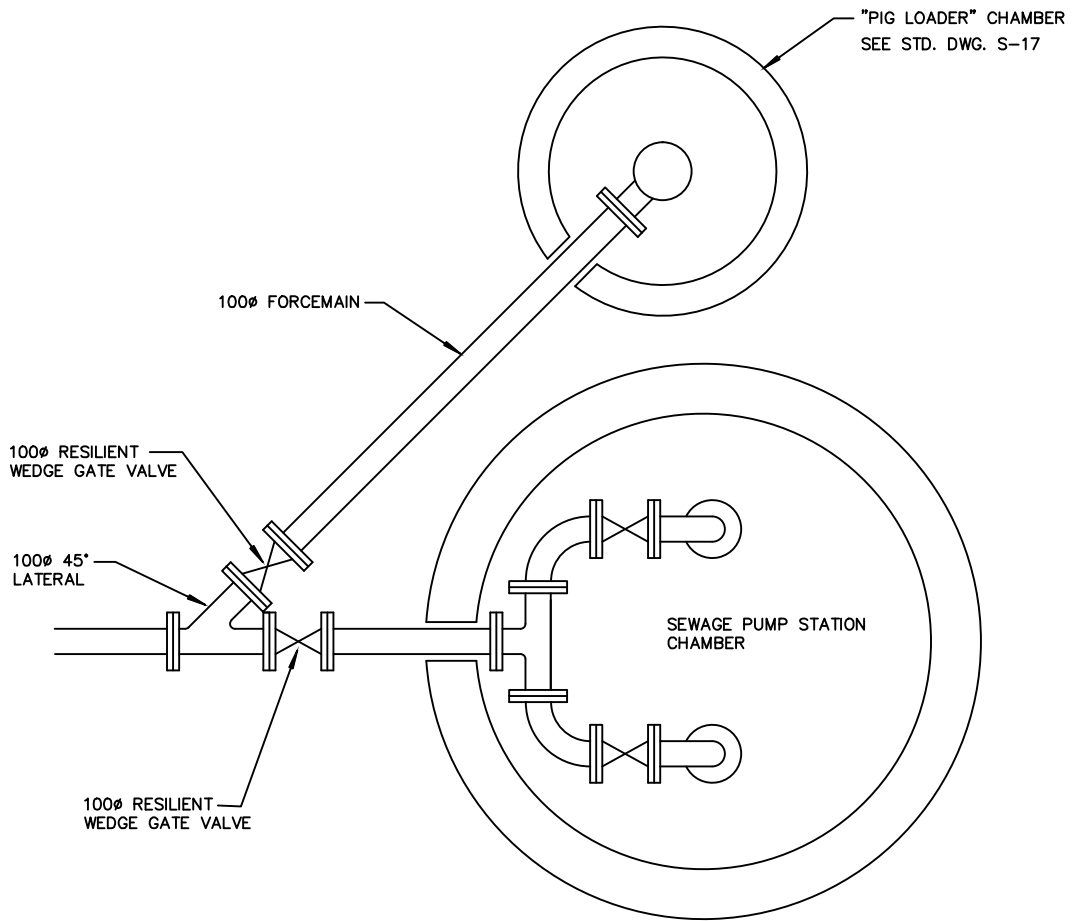

NOTES

1. ACTUAL LOCATION OF "PIG LOADER" CHAMBER TO SUIT SITE DESIGN
2. ONLY PRODUCTS APPROVED BY THE SUPERINTENDENT AND LISTED IN THE DISTRICT OF TOFINO APPROVED UTILITY PRODUCTS LIST WILL BE ACCEPTED FOR INSTALLATION.

| | | |
|---|---|---|
| 3 | | DIMENSIONS ARE IN MILLIMETERS UNLESS OTHERWISE NOTED |
| 2 | | |
| 1 | | TITLE SEWAGE PUMP STATION "PIG LOADER" SCHEMATIC |
| | REVISION DATE APPROVED | |
|  DISTRICT OF TOFINO | SUBDIVISION & DEVELOPMENT CONTROL BYLAW | APPROVED |
| | | DATE OCT, 2015 |
| | | DRAWN BY JEA |
| | | DRAWING NUMBER S29-SD |

Short Duration Rainfall Intensity-Duration-Frequency Data
Données sur l'intensité, la durée et la fréquence des chutes de pluie de courte durée

2014/12/21

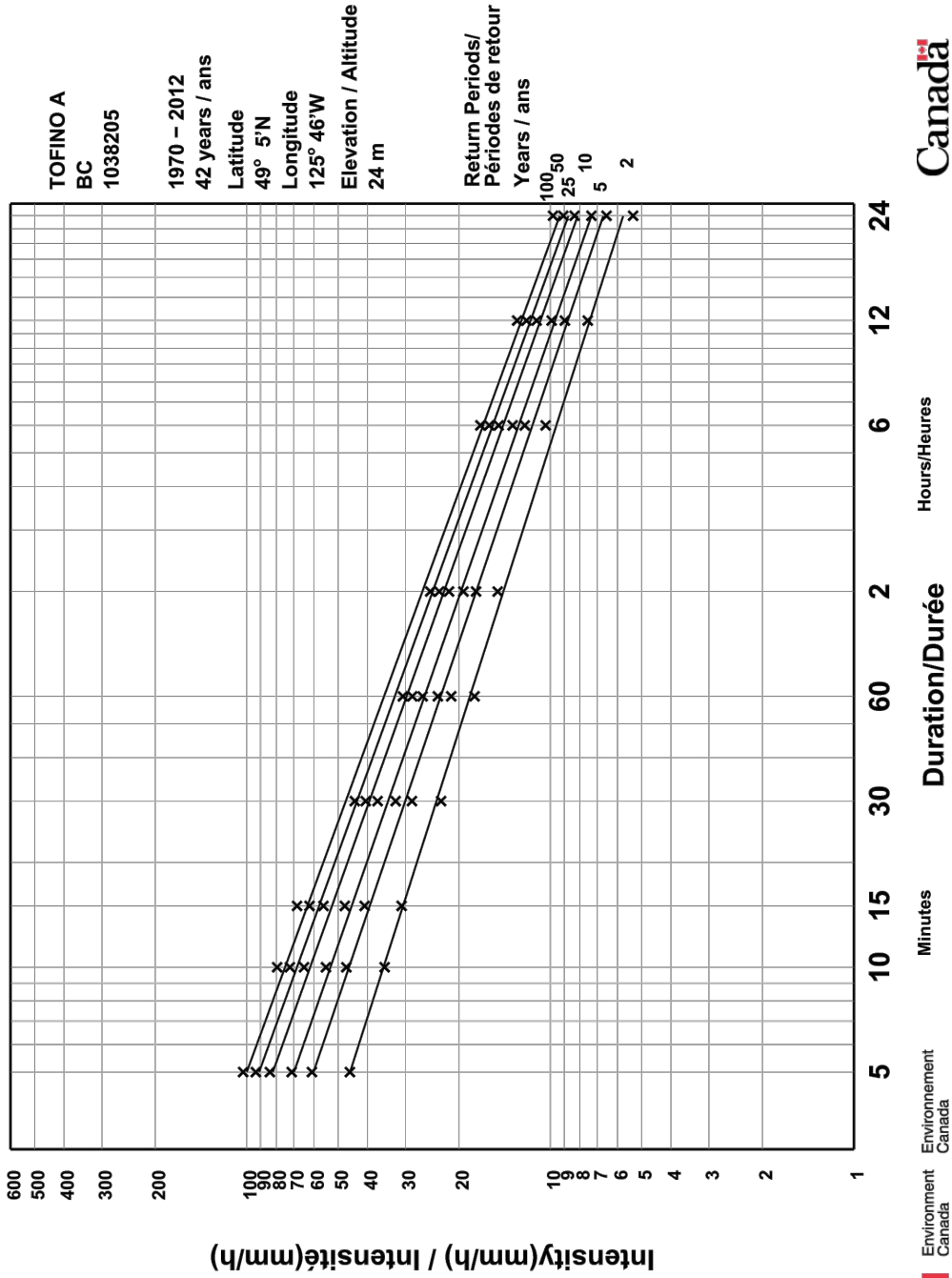

| | | |
|---|---------------------------|---|
| 3 | | |
| 2 | | |
| 1 | | |
| | REVISION DATE | APPROVED |
| | DISTRICT OF TOFINO | SUBDIVISION & DEVELOPMENT CONTROL BYLAW |

| | | |
|----------------|-----------|---|
| TITLE | | TOFINO SHORT DURATION RAINFALL INTENSITY - DURATION - FREQUENCY DATA |
| APPROVED | | |
| DATE | OCT, 2015 | |
| DRAWN BY | JEA | |
| DRAWING NUMBER | | S30-SD |

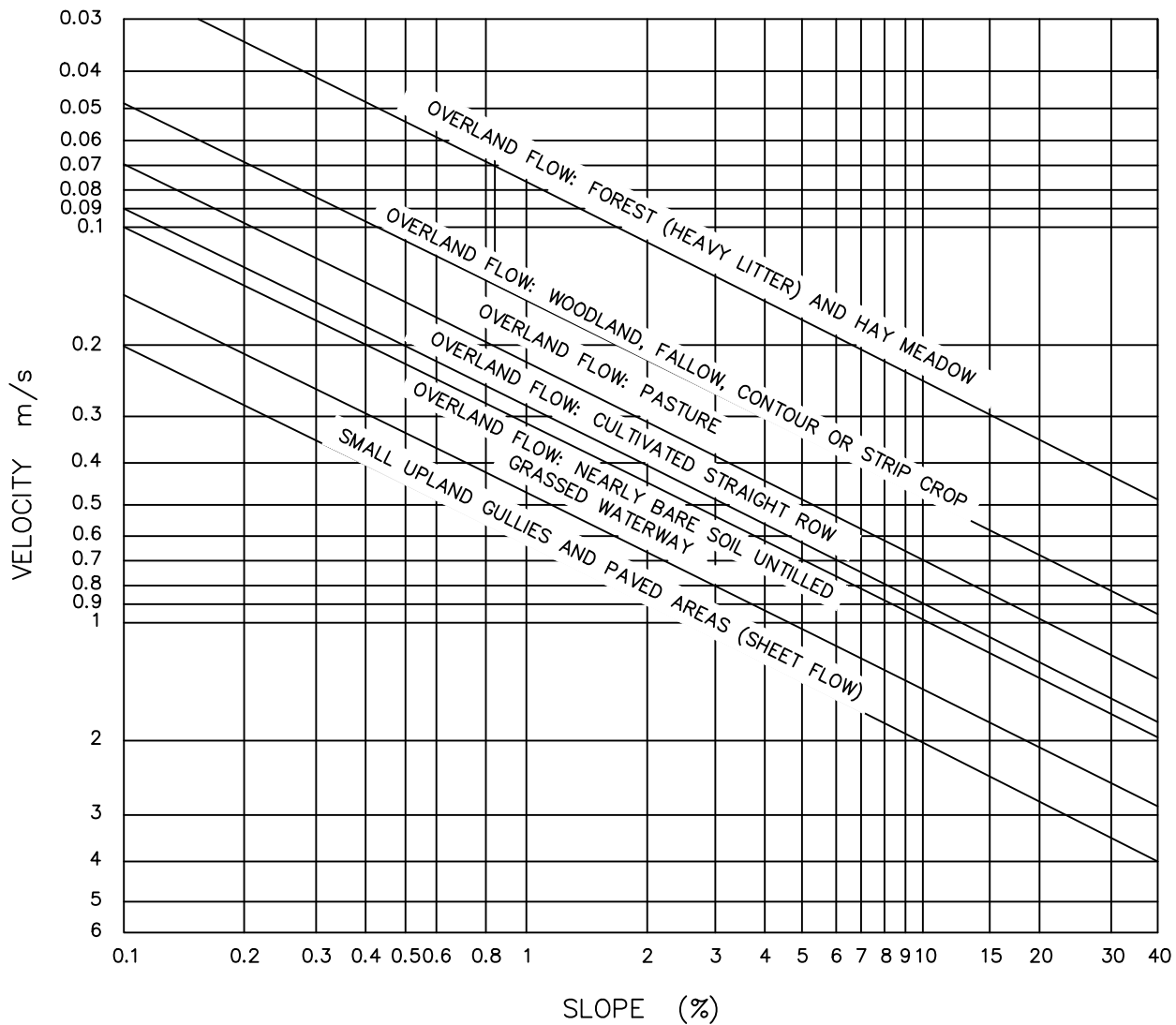

UPLAND METHOD FOR ESTIMATING TIME OF CONCENTRATION

NOTES:

1. THIS TABLE IS LIMITED FOR USE IN DRAINAGE BASINS UP TO 10 km²
2. THIS TABLE DOES NOT MAKE ALLOWANCES FOR VARIATIONS IN SOIL TYPES AND MAY UNDERESTIMATE TIMES FOR PERMEABLE BASINS

| | | | | |
|---|---------------|----------|----------|------------------------------------|
| 3 | | | | |
| 2 | | | | |
| 1 | | | TITLE | TIME OF CONCENTRATION TABLE |
| | REVISION DATE | APPROVED | | |
| | | | APPROVED | DRAWING NUMBER |
| | | | DATE | OCT, 2015 |
| | | | DRAWN BY | JEA |
| | | | | S31-SD |



**DISTRICT OF
TOFINO**

SUBDIVISION &
DEVELOPMENT
CONTROL BYLAW

Schedule 'F' - District of Tofino - Supplemental Specifications

Watermain - Drawing Index

| Watermains | | | |
|------------------------------|--|------------------------------------|---|
| MMCD Standard Detail Drawing | | Tofino Supplemental Detail Drawing | |
| W1 | | | Use as required |
| | | W1-SD | Thrust Block Details with Sizing |
| W2A | Water Service Connection – Service Box | | Do Not Use |
| W2B | Water Service Connection – Valve Box | | Do Not Use |
| W2C | Meter Installation for 19mm and 25mm Service Connections | | Do Not Use |
| W2D | Meter Installation for 38mm and 50mm Service Connections | | Use MMCD Drawing. |
| | | W2-SD | Water Service Connection – 25mm to 50mm |
| W3 | Gate Valve Installation | | Use MMCD Drawing. 100mm clear between PVC Riser and Nelson Box Lid. PVC Riser to be PVC C900 DR18 Tracer Wire up the outside of the PVC Riser and between the riser and the Nelson Box |
| W4 | Fire Hydrant Installation | | Use MMCD Drawing Hydrant minimum 900mm cover, maximum 1500mm. Hydrant flange 100mm above ground level. Do not apply note 3 (plug in drain hole) |
| | | W4A-SD | Hydrant Access – Ditch Crossing Detail |
| W5 | Test Point Installation | | Use MMCD Drawing |
| W6 | Air Valve Assembly – 25 and 50mm Valves | | Do Not Use |
| | | W6A-SD | Air Release Valve Assembly and Chamber for 150mm to 300mm Mains |
| W7 | Air Valve Assembly- 100mm valve | | Do Not Use |
| W8 | Blow Off for Watermain | | Do Not Use |
| | | W8A-SD | Above Ground Flushout Detail |

Schedule 'F' - District of Tofino - Supplemental Specifications

Watermain - Drawing Index

| | | | |
|-----|--------------------------|--------|---|
| | | W8B-SD | Below Grade Flushout Detail |
| W9 | Blow-Down Chamber | | Use as required |
| W10 | Waterworks Chamber Drain | | Use as required |
| | | W11-SD | Precast Vault Meter Chamber |
| | | W12-SD | Fire / Domestic Water Meter Piping Layout (100 to 150) |
| | | W13-SD | Domestic Water Meters Piping Layout (75 to 150) |
| | | W14-SD | Detector Check Fire Line Service Piping Layout (100 to 150) |
| | | W15-SD | Fire / Domestic Water Service Piping Layout (38 to 100) |

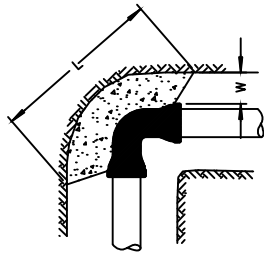

HORIZONTAL 90° BEND

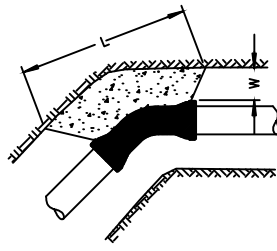

HORIZONTAL 45° BEND

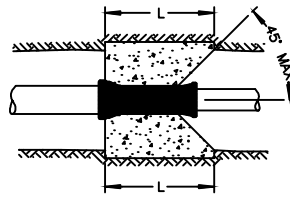

REDUCER

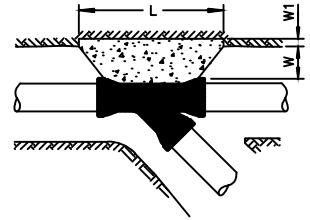

WYE

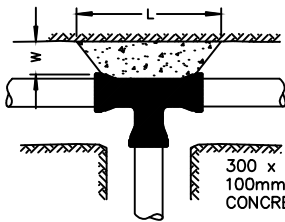

TEE

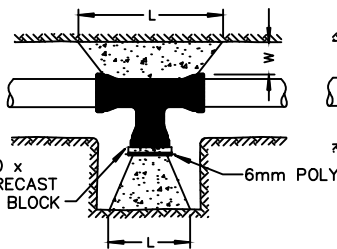

TEE WITH PLUG

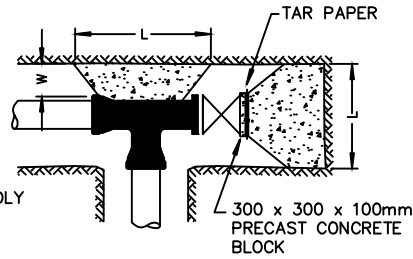

TEE WITH VALVE

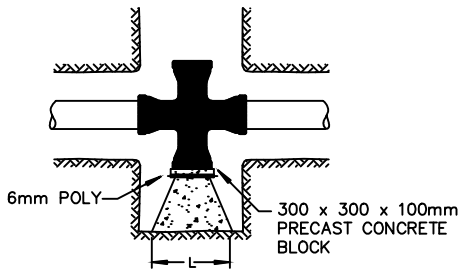
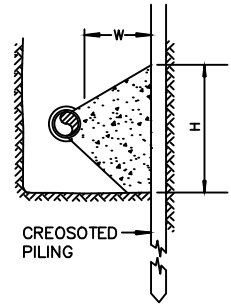

CROSS WITH PLUG

NOTES:

1. DIMENSIONS APPLY TO THE LARGER DIAMETER END OF THE FITTING.
2. CONCRETE MINIMUM COMPRESSIVE STRENGTH SHALL BE 20MPa @ 28DAYS.

| MINIMUM THRUST AREAS FOR FITTINGS AT 1034 kPA PRESSURE AND FOR SOILS WITH MIN. BEARING OF 96kPa (NOT TO BE USED FOR SOFT CLAY, MUCK, PEAT, etc.) | | | | | | | | | | | |
|---|--------------|------------------------------------|------|--------|--------------------------------|-----------------|------------------------------------|-----|------------------|--------|--------|
| TYPE OF FITTING | FITTING SIZE | OUTSIDE OF FITTING TO BEARING FACE | | LENGTH | HEIGHT | TYPE OF FITTING | OUTSIDE OF FITTING TO BEARING FACE | | RECESS IN TRENCH | LENGTH | HEIGHT |
| | | D | W | | | | D | W | | | |
| 90° BEND | 150 | 300 | 900 | 450 | CROSS | 150 | 300 | | | 600 | 450 |
| | 200 | 350 | 1050 | 600 | | 750 | 600 | | | | |
| | 250 | 375 | 1450 | 750 | | 1000 | 750 | | | | |
| | 300 | 400 | 1650 | 900 | | 1200 | 900 | | | | |
| 45° BEND | 150 | 300 | 450 | 450 | 45° WYE | 150 | 300 | 300 | | 450 | 450 |
| | 200 | 350 | 600 | 600 | | 400 | 600 | | | | |
| | 250 | 375 | 750 | 750 | | 500 | 750 | | | | |
| | 300 | 400 | 900 | 900 | | 600 | 900 | | | | |
| 11 1/4° BEND 22 1/2° BEND | 150 | 300 | 450 | 225 | * REDUCER | 150 | 300 | 150 | | 450 | 450 |
| | 200 | 350 | 600 | 300 | | 200 | 600 | | | | |
| | 250 | 375 | 835 | 450 | | 250 | 750 | | | | |
| | 300 | 400 | 900 | 450 | | 300 | 900 | | | | |
| TEE | 150 | 300 | 600 | 450 | CAPS AND PLUGS (IF NOT BOLTED) | 150 | 300 | | | 450 | 450 |
| | 200 | 350 | 750 | 600 | | 600 | 600 | | | | |
| | 250 | 375 | 1000 | 750 | | 750 | 750 | | | | |
| | 300 | 400 | 1200 | 900 | | 900 | 900 | | | | |

| | | | | | |
|---------------------------|---|---|----------------|--|-----------|
| 3 | | DIMENSIONS ARE IN MILLIMETERS UNLESS OTHERWISE NOTED | | | |
| 2 | | | | | |
| 1 | | | | | |
| | REVISION DATE | APPROVED | TITLE | THRUST BLOCK DETAILS AND SIZING | |
| DISTRICT OF TOFINO | SUBDIVISION & DEVELOPMENT CONTROL BYLAW | | APPROVED | W1-SD | |
| | | | DATE | | OCT, 2015 |
| | | | DRAWN BY | | JEA |
| | | | DRAWING NUMBER | | |

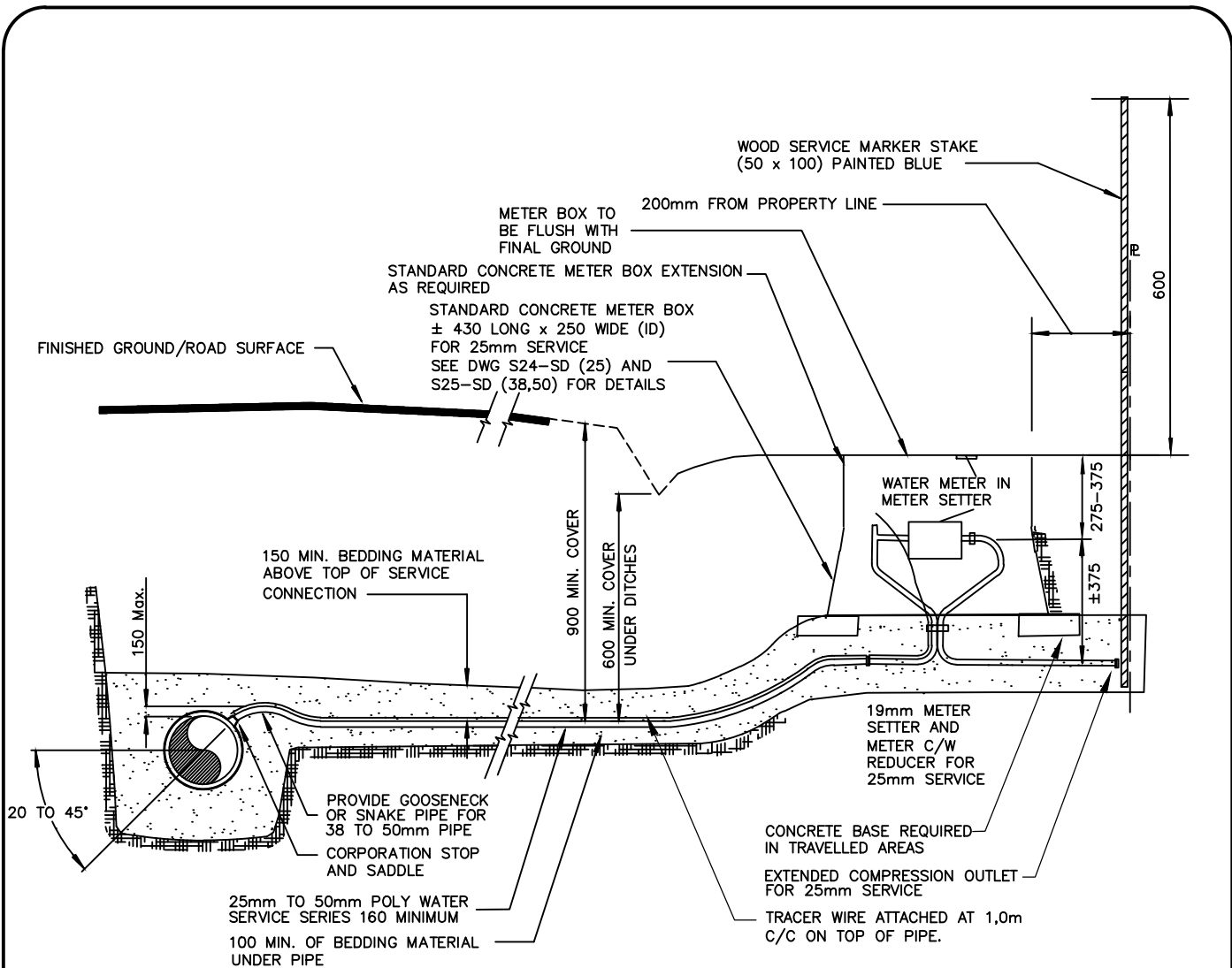

FOR 38 AND 50mm
METER INSTALLATION
DETAILS, SEE MMCD
DWG. W2d.

NOTES:

1. NOMINAL TRENCH WIDTH FOR SERVICE CONNECTION IS 600
2. CONCRETE METER BOX SHALL BE INSTALLED AS PART OF THE INITIAL SERVICE INSTALLATION
3. FOR 25Ø WATER CONNECTIONS METER BOXES SHALL BE CONCRETE WITH LID MOUNT PIT ANTENNAE COMPATIBLE STEEL LIDS.
4. USING PLASTIC METER BOXES IN EXISTING LANDSCAPED AREAS REQUIRES APPROVAL BY THE SUPERINTENDENT.
5. ONLY PRODUCTS APPROVED BY THE SUPERINTENDENT AND LISTED IN THE DISTRICT OF TOFINO APPROVED PRODUCTS LIST WILL BE ACCEPTED FOR INSTALLATION.
6. TRACER WIRE TO BE WRAPPED AROUND CORP STOP AND METER SETTER TO MAINTAIN WIRE IN PLACE.
7. METER SETTERS TO INCLUDE DUAL CHECK VALVE AND SHUT OFF.
8. SINGLE FAMILY HOMES TO INCLUDE 25mm SERVICE, REDUCER ON TUBING / SETTER CONNECTION, AND 19mm METER SETTER AND METER.
9. SEE TOFINO APPROVED PRODUCTS LIST FOR MATERIAL.
10. METER TO BE SUPPLIED AND INSTALLED BY DISTRICT OF TOFINO

| | | | |
|---|---------------|--|--------------------------------|
| 3 | | DIMENSIONS ARE IN MILLIMETERS UNLESS OTHERWISE NOTED | |
| 2 | | TITLE WATER SERVICE CONNECTION 25mm TO 50mm | |
| 1 | | | |
| | REVISION DATE | APPROVED | |
|  DISTRICT OF TOFINO | | SUBDIVISION & DEVELOPMENT CONTROL BYLAW | APPROVED |
| | | DATE | OCT, 2015 |
| | | DRAWN BY | JEA |
| | | | DRAWING NUMBER W2-SD |

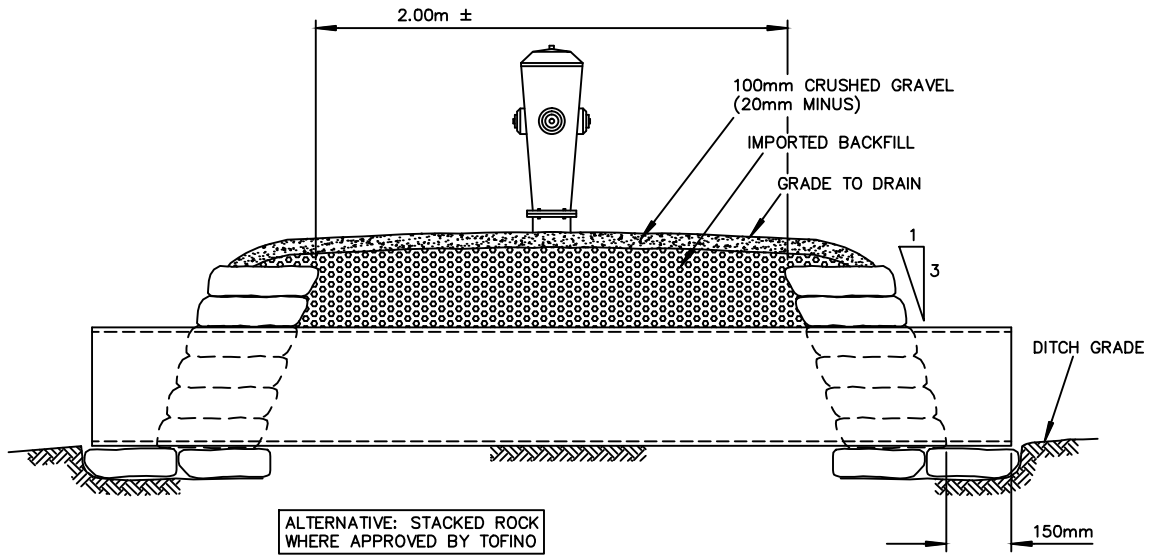

SECTION A-A

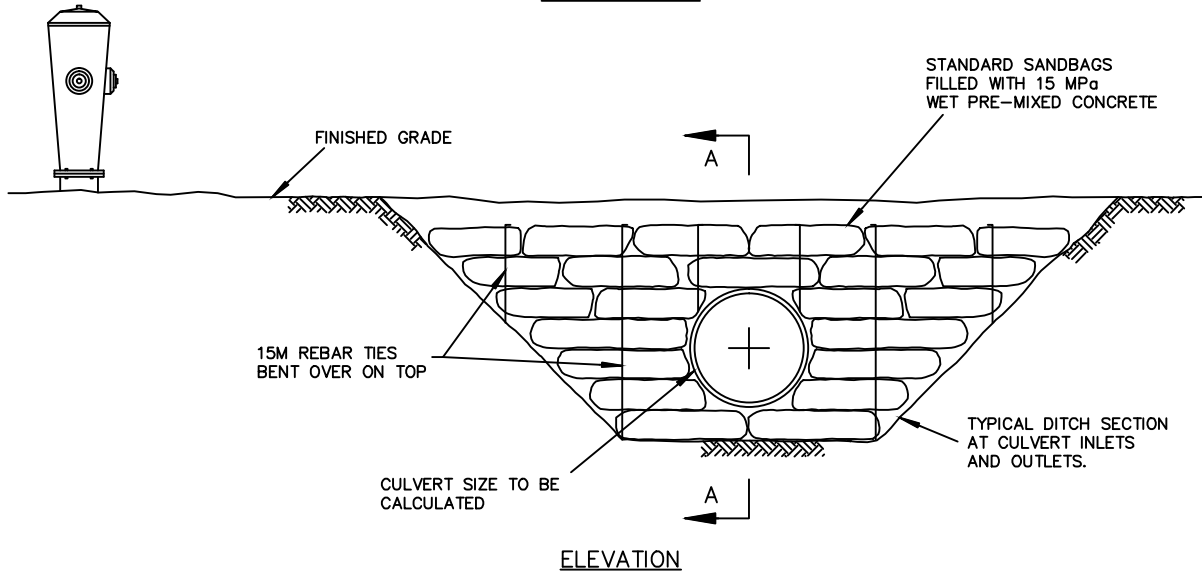

ELEVATION

NOTES

1. IF THE HORIZONTAL DIRECTION OF FLOW AT CULVERT INLETS AND OUTLETS EXCEEDS 30°, THE THE SANDBAG BULKHEADS REQUIRE CURVED WING WALLS TO FUNNEL THE FLOW.
2. ONLY PRODUCTS APPROVED BY THE SUPERINTENDENT AND LISTED IN THE DISTRICT OF TOFINO APPROVED UTILITY PRODUCTS LIST WILL BE ACCEPTED FOR INSTALLATION.

| | | |
|---|---|---|
| 3 | | DIMENSIONS ARE IN MILLIMETERS UNLESS OTHERWISE NOTED |
| 2 | | |
| 1 | | TITLE |
| | REVISION DATE | APPROVED |
| | | HYDRANT ACCESS DITCH CROSSING DETAIL |
|  DISTRICT OF TOFINO | SUBDIVISION & DEVELOPMENT CONTROL BYLAW | APPROVED |
| | | DATE |
| | | DRAWN BY |
| | | OCT, 2015 |
| | | JEA |
| | | DRAWING NUMBER |
| | | W4A-SD |

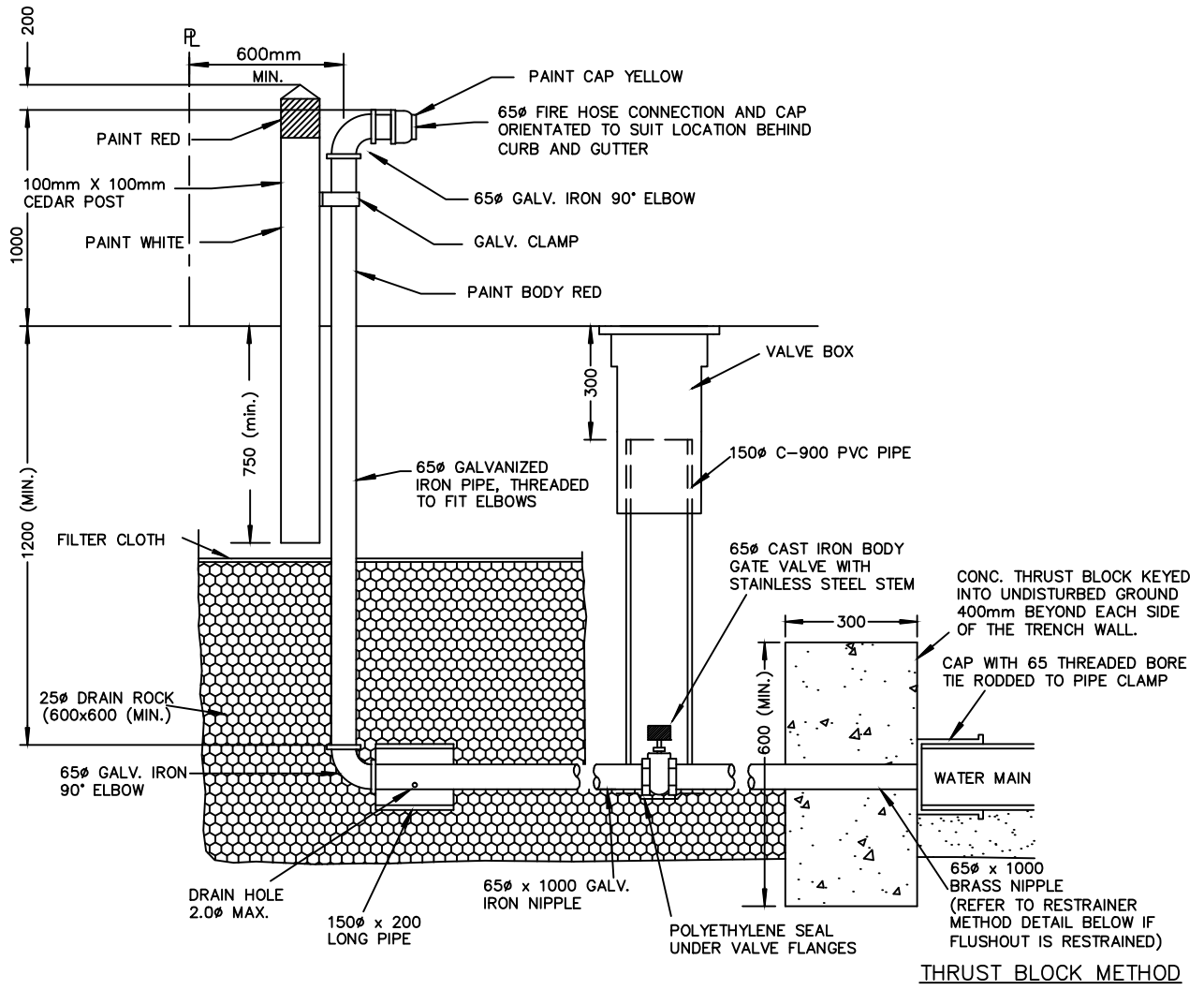

NOTES:

1. NOMINAL TRENCH WIDTH FOR FLUSHOUT IS 600mm
VALVE BOX NOT TO CONFLICT WITH CURB AND GUTTER
CURB AND GUTTER NOT SHOWN
2. 150mm x 200mm PIPE TO BE PLACED AROUND PIPE
AT DRAIN HOLE TO PREVENT EROSION.
3. ABOVE GROUND FLUSHOUT TO BE RESTRAINED
AS PER THRUST BLOCK OR RESTRAINER METHOD
AT THE DISCRETION OF THE SUPERINTENDENT.
4. WHEN RESTRAINER METHOD IS USED, RESTRAIN AS PER
MANUFACTURERS RECOMMENDATIONS.
5. ONLY PRODUCTS APPROVED BY SUPERINTENDENT AND
LISTED IN THE DISTRICT OF TOFINO APPROVED UTILITY PRODUCTS
LIST WILL BE ACCEPTED FOR INSTALLATION
6. ALL DIMENSIONS ARE IN MILLIMETERS UNLESS OTHERWISE SHOWN

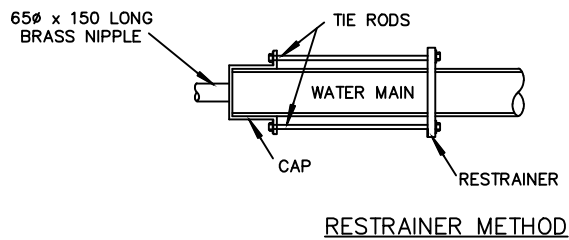

| | | | |
|---|--|---|---------------------------------|
| 3 | | DIMENSIONS ARE IN MILLIMETERS UNLESS OTHERWISE NOTED | |
| 2 | | TITLE | |
| 1 | | ABOVE GROUND FLUSHOUT DETAIL | |
| | REVISION DATE | APPROVED | |
|  DISTRICT OF TOFINO | SUBDIVISION & DEVELOPMENT CONTROL BYLAW | | APPROVED |
| | | | DATE OCT, 2015 |
| | | | DRAWN BY JEA |
| | | | DRAWING NUMBER W8A-SD |

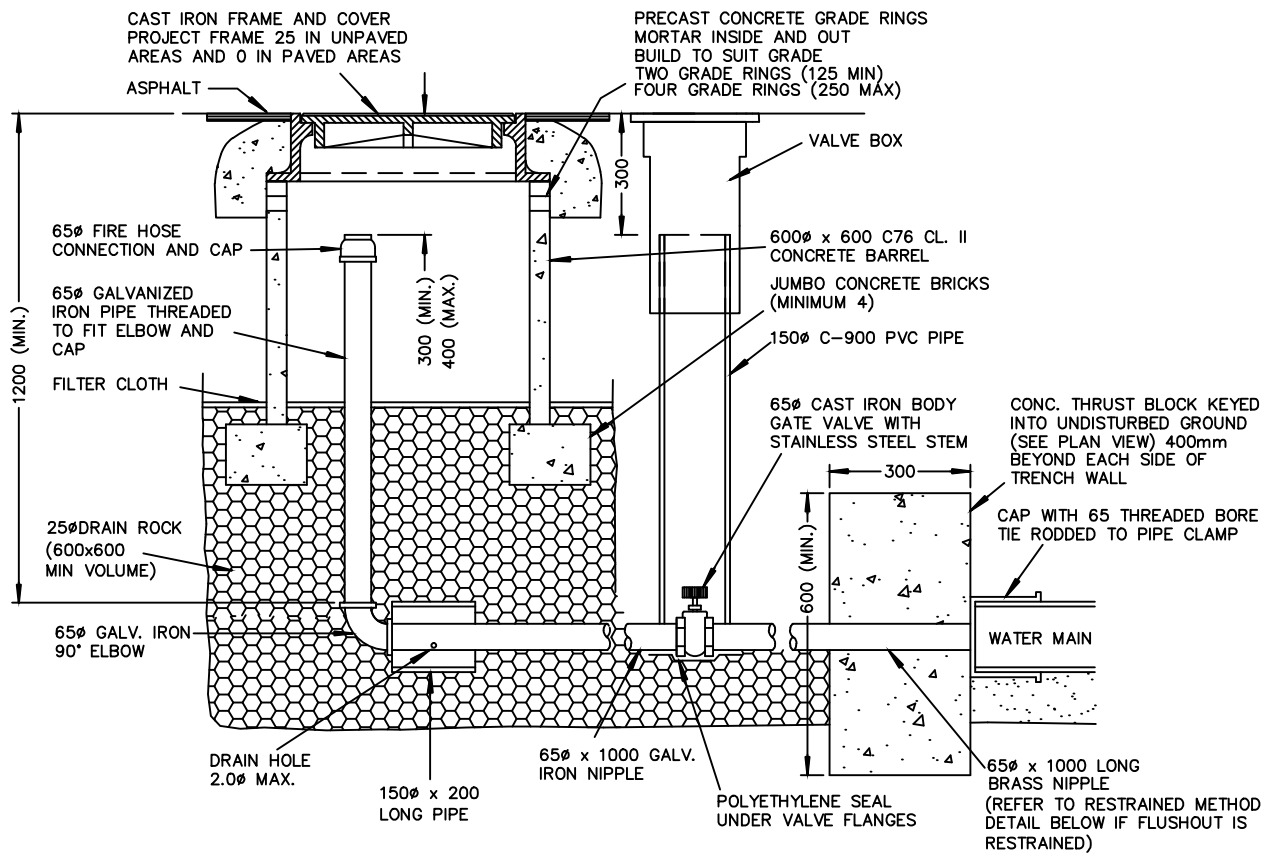

THRUST BLOCK METHOD

NOTES:

1. NOMINAL TRENCH WIDTH FOR FLUSHOUT IS 600mm VALVE BOX NOT CONFLICT WITH CURB AND GUTTER CURB AND GUTTER NOT SHOWN.
2. LETTERING ON MANHOLE COVER SHALL REFER TO "CITY OF NANAIMO WATERWORKS" LETTERING SHALL BE 25 FLATTENED FACE GOTHIC LETTERING WITH FACE OF LETTERS RAISED TO THE SAME ELEVATION AS THE TOP OF THE RIBS.
3. NOT TO BE USED IN AREAS WHERE WATER TABLE COULD BE ABOVE FIRE HOSE CONNECTION.
4. SURROUNDING GRADE TO DRAIN AWAY FROM COVER.
5. 150mm x 200mm PIPE TO BE PLACED AROUND PIPE AT DRAIN HOLE TO PREVENT EROSION.
6. FLUSH OUTS LOCATED ON GRAVEL ROADS OR SHOULDERS REQUIRE A 1.5 M X 1.5 M HOT MIX ASPHALT APRON, 50 mm THICK.
7. BELOW GRADE FLUSHOUT TO BE RESTRAINED AS PER THRUST BLOCK OR RESTRAINER METHOD AT THE DISCRETION OF THE SUPERINTENDENT.
8. WHEN RESTRAINER METHOD IS USED, RESTRAIN AS PER MANUFACTURERS RECOMMENDATIONS.
9. ONLY PRODUCTS APPROVED BY THE SUPERINTENDENT AND LISTED IN THE DISTRICT OF TOFINO APPROVED UTILITY PRODUCTS LIST WILL BE ACCEPTED FOR INSTALLATION.

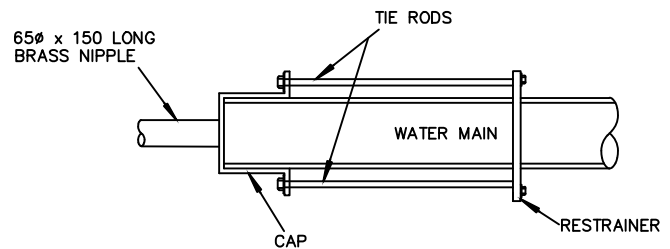

RESTRAINER METHOD

| | | | | |
|---|---|----------|---|--|
| 3 | | | DIMENSIONS ARE IN MILLIMETERS UNLESS OTHERWISE NOTED | |
| 2 | | | TITLE BELOW GRADE FLUSHOUT DETAIL | |
| 1 | | | | |
| | REVISION DATE | APPROVED | | |
|  DISTRICT OF TOFINO | SUBDIVISION & DEVELOPMENT CONTROL BYLAW | | DRAWING NUMBER W8B-SD | |
| | APPROVED | | DATE OCT, 2015 | |
| | DRAWN BY JEA | | | |

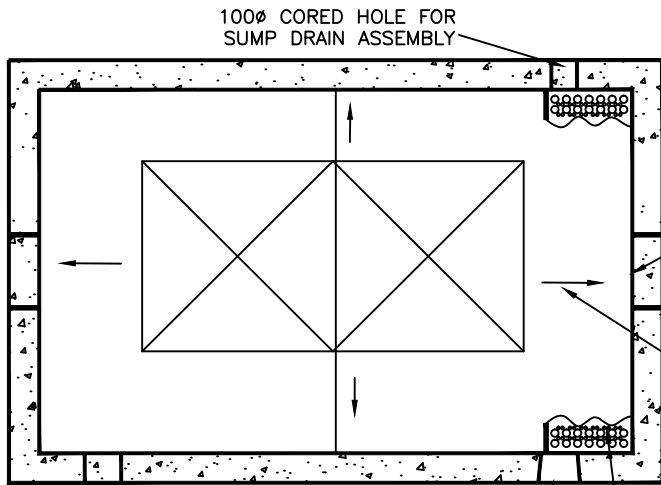

PLAN

ALUMINUM OR GALVANIZED STEEL COVERS (H2O STATIC LOAD)

SLOPE ALL AROUND TO PREVENT WATER ENTRY

1500X300X300 DEEP SUMP C/W SUMP GRATING

157x127 KNOCK OUT FOR SUMP DRAIN

FOR GENERAL INFORMATION ONLY DESIGN TO BE COMPLETED AND SEALED BY A PROFESSIONAL ENGINEER

ALUMINUM OR GALVANIZED STEEL COVER (H2O STATIC LOAD)

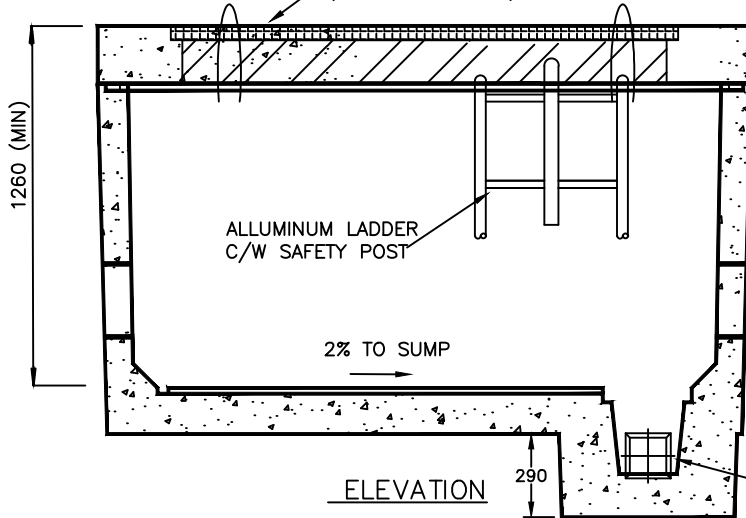

ELEVATION

MINIMUM INTERVAL DIMENSION FOR THE PRECAST VAULT METER CHAMBER

| DOMESTIC/FIRE METER | LENGTH | WIDTH |
|---------------------|--------|-------|
| 100-150ø | 2000 | 1200 |
| 150-250ø | 2500 | 1500 |

WHERE DRAINS CANNOT REASONABLY BE INSTALLED, ALTERNATIVES SUCH AS SEALED CHAMBERS AND SEALED LIDS OR SUMP JET WITH BACKFLOW PREVENTION MAY BE CONSIDERED

SUMP DRAIN TO BE CONNECTED TO CLOSEST STORM DRAIN C/W BACKFLOW CONSIDERATION

NOTES:

- USE THIS DRAWING ONLY AS A GUIDE. DETAIL DESIGN SHALL CONSIDER EXISTING SITE AND SOIL CONDITIONS AND INCLUDE STEEL REINFORCEMENT.
- DESIGN CONCRETE VAULT TO WITHSTAND CS600 LOADING.
- SIZE VAULT TO PROVIDE MINIMUM CLEARANCES AS REQUIRED FOR ACCESS AND MAINTENANCE AND WCB REQUIREMENTS.
- CHAMBERS LOCATED ON GRAVEL ROADS OR SHOULDERS REQUIRE A 1.5m X 1.5m HOT MIX ASPHALT PERIMETER APRON, 50 mm THICK.
- PROVIDE ANTI-FLOATATION WHERE REQUIRED.
- ONLY PRODUCTS APPROVED BY THE SUPERINTENDENT AND LISTED IN THE DISTRICT OF TOFINO APPROVED UTILITY PRODUCTS LIST WILL BE ACCEPTED FOR INSTALLATION.

OPTIONS, PARTICULARLY WHEN SUITABLE DRAINS ARE NOT AVAILABLE:

- CHAMBERS MUST BE COMPLETELY SEALED
- HATCHES TO BE 915 x 915 ALUMINUM, CLASS B OCCASIONAL LOADING, PADLOCK HASP, SPRING ASSISTED DRIP PROOF TROUGH TO DRAIN BEYOND CHAMBER, SEALED AND SURROUNDED WITH CONCRETE ON PRECAST CONCRETE COVER SLAB CS600 LOADING. TOP OF HATCH 100mm ABOVE GROUND AND TO BE PROTECTED FROM TRAFFIC.
- CHAMBER SIZED TO SUIT. 1800mm MANHOLE FOR SMALL FIRE METERS, OR ARMTEC 251815 FIREMETER CHAMBER (ARRANGED SO MAINTENANCE IS DONE FROM HATCH OPENING AREA).
- ACCESSORIES AS REQUIRED, INCLUDING LADDER C/W SAFETY POST, SUMP, ETC.

| | | | | |
|---|---|---|---|-----------|
| 3 | | DIMENSIONS ARE IN MILLIMETERS UNLESS OTHERWISE NOTED | | |
| 2 | | | | |
| 1 | | | | |
| | REVISION DATE | APPROVED | TITLE PRECAST VAULT METER CHAMBER | |
|  DISTRICT OF TOFINO | SUBDIVISION & DEVELOPMENT CONTROL BYLAW | APPROVED | DRAWING NUMBER W11-SD | |
| | | DATE | | OCT, 2015 |
| | | DRAWN BY | | JE A |

DETAILS FOR METER CHAMBER
REFER TO DRAWING W-11-SD

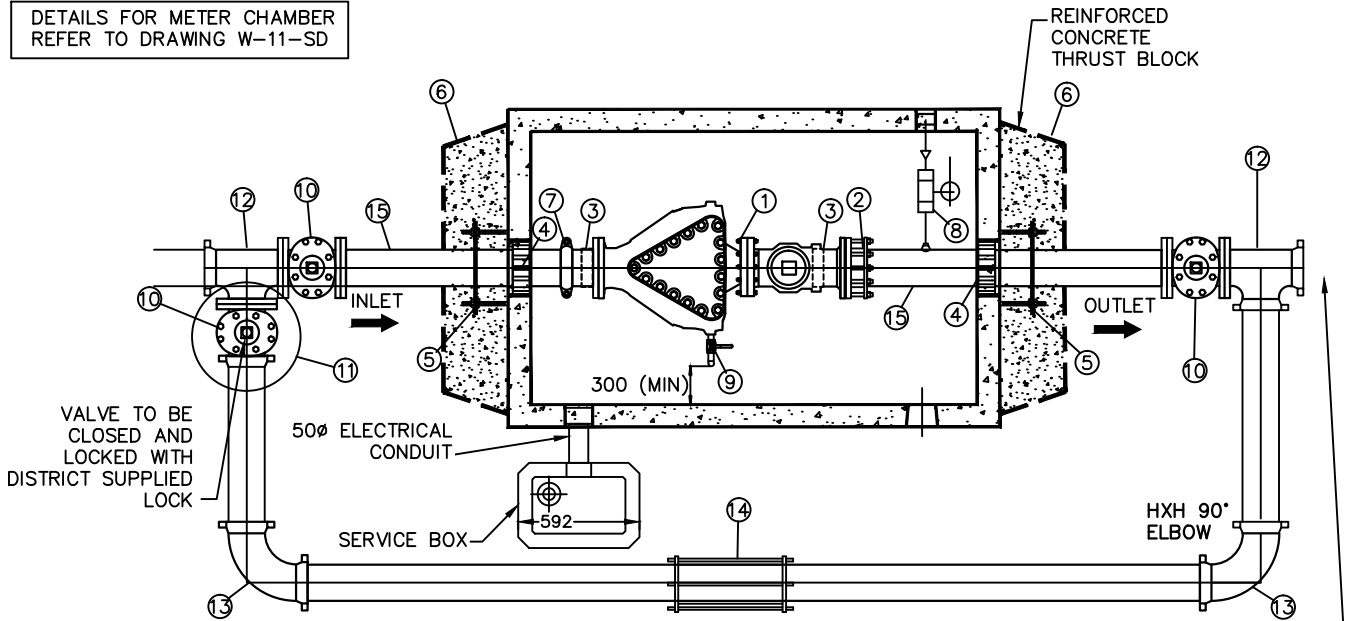

PLAN

FOR GENERAL INFORMATION ONLY
DESIGN TO BE COMPLETED AND
SEALED BY A PROFESSIONAL
ENGINEER

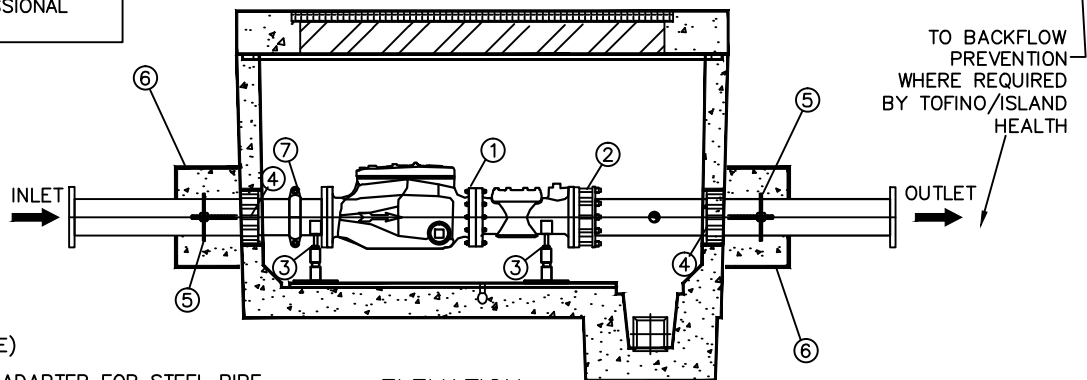

ELEVATION

MATERIAL LIST

- ① WATER METER (FIRE)
- ② FLANGE COUPLING ADAPTER FOR STEEL PIPE
- ③ GALVANIZED STEEL ADJUSTABLE PIPE SUPPORT
- ④ PIPE SEAL ASSEMBLY
- ⑤ THRUST-SEAL PLATE C/W BOLTS
- ⑥ REINFORCED CONCRETE THRUST BLOCK
- ⑦ COUPLING
- ⑧ SUMP JET (OPTIONAL)
- ⑨ STRAINER DRAIN ASSEMBLY
- ⑩ GATE VALVE
- ⑪ VALVE BOX C/W LOCKING LID
- ⑫ TEE
- ⑬ 90° ELBOW
- ⑭ COUPLING
- ⑮ STEEL PIPE, SEE NOTE 3

NOTE:

- 1. THRUST BLOCKING TO BE INSTALLED AS REQUIRED.
- 2. METER ASSEMBLY TO BE SUPPORTED BY STEEL PIPE SUPPORTS AS REQUIRED
- 3. FABRICATED STEEL PIPE AND FITTING TO BE SCHEDULE 40 SANDBLASTED, EPOXY LINED, AND COATED TO AWWA C-210 & NSF-61 SPECIFICATION.
- 4. TEST POINTS AND DRAIN ASSEMBLIES TO INCLUDE PLUG FOR UNDERGROUND INSTALLATIONS.
- 5. ONLY PRODUCTS APPROVED BY THE SUPERINTENDENT OR LISTED IN THE DISTRICT OF TOFINO APPROVED UTILITY PRODUCTS LIST WILL BE ACCEPTED FOR INSTALLATION. ONLY UL/FM LISTED PRODUCTS SHALL BE APPROVED FOR FIRELINE SERVICE.
- 6. TO BE LOCATED IN A DISTRICT SRW

TO BACKFLOW
PREVENTION
WHERE REQUIRED
BY TOFINO/ISLAND
HEALTH

| | |
|---|-----------------------------|
| 3 | |
| 2 | |
| 1 | |
| | REVISION DATE APPROVED |

DIMENSIONS ARE IN MILLIMETERS
UNLESS OTHERWISE NOTED

| | | | |
|----------|-----------|---|--|
| TITLE | | FIRE/DOMESTIC WATER METER PIPING LAYOUT (100 TO 150) | |
| APPROVED | | DRAWING NUMBER | |
| DATE | OCT, 2015 | W12-SD | |
| DRAWN BY | JEA | | |



**DISTRICT OF
TOFINO**

SUBDIVISION &
DEVELOPMENT
CONTROL BYLAW

MATERIAL LIST

- ① GATE VALVE
- ② WATER METER
- ③ FLANGED COUPLING ADAPTOR
- ④ SILENT CHECK VALVE
- ⑤ LOCKING BALL VALVE
- ⑥ COUPLING
- ⑦ TEST PORT WITH VALVE (FOR 100# METERS OR LARGER)
- ⑧ THRUST RINGS

PRECAST VAULT
METER CHAMBER

SEE DRAWING W-11-SD
FOR METER CHAMBER
DETAILS

FOR GENERAL INFORMATION ONLY
DESIGN TO BE COMPLETED AND
SEALED BY A PROFESSIONAL
ENGINEER

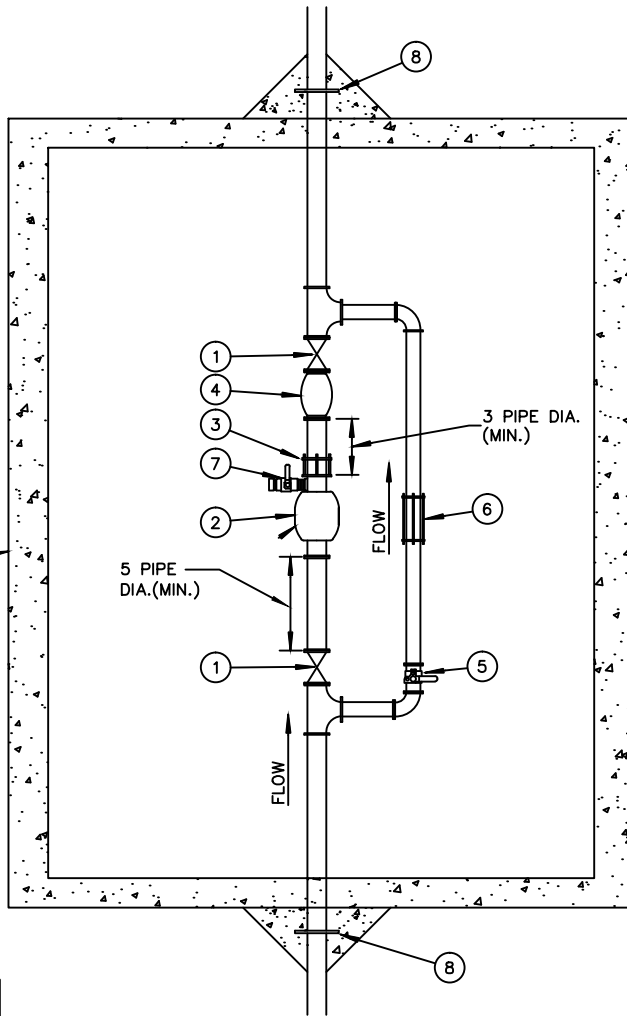

NOTES:

- 1. METER ASSEMBLY TO BE SUPPORTED BY STEEL PIPE SUPPORTS AS REQUIRED.
- 2. TEST POINTS AND DRAIN ASSEMBLIES TO INCLUDE PLUG FOR UNDERGROUND INSTALLATIONS.
- 3. THRUST BLOCKING TO BE INSTALLED AS REQUIRED.
- 4. METER BY-PASS MAY BE INSTALLED OUTSIDE THE CHAMBER.
- 5. ONLY PRODUCTS APPROVED BY THE SUPERINTENDENT AND LISTED IN THE DISTRICT OF TOFINO APPROVED UTILITY PRODUCT LIST WILL BE ACCEPTED FOR INSTALLATION.
- 6. TO BE LOCATED IN A DISTRICT SRW

| | | |
|---|---|--|
| 3 | | DIMENSIONS ARE IN MILLIMETERS UNLESS OTHERWISE NOTED |
| 2 | | |
| 1 | | TITLE DOMESTIC WATER METERS PIPING LAYOUT (75 TO 150) |
| | REVISION DATE APPROVED | |
|  DISTRICT OF TOFINO | SUBDIVISION & DEVELOPMENT CONTROL BYLAW | APPROVED |
| | | DATE OCT, 2015 |
| | | DRAWN BY JEA |
| | | DRAWING NUMBER W13-SD |

MATERIAL LIST

- ① GATE VALVE (OS&Y) (COULD BE LOCATED ON OUTSIDE OF CHAMBER)
- ② CHECK VALVE
- ③ BY-PASS METER, TOFINO STANDARD
- ④ LOCKING BALL VALVE
- ⑤ DETECTOR CHECK
- ⑥ THRUST RING
- ⑦ FLANGED COUPLING ADAPTOR
- ⑧ STEEL PIPE, SEE NOTE 4

SEE DRAWING W-11-SD FOR CHAMBER DETAILS

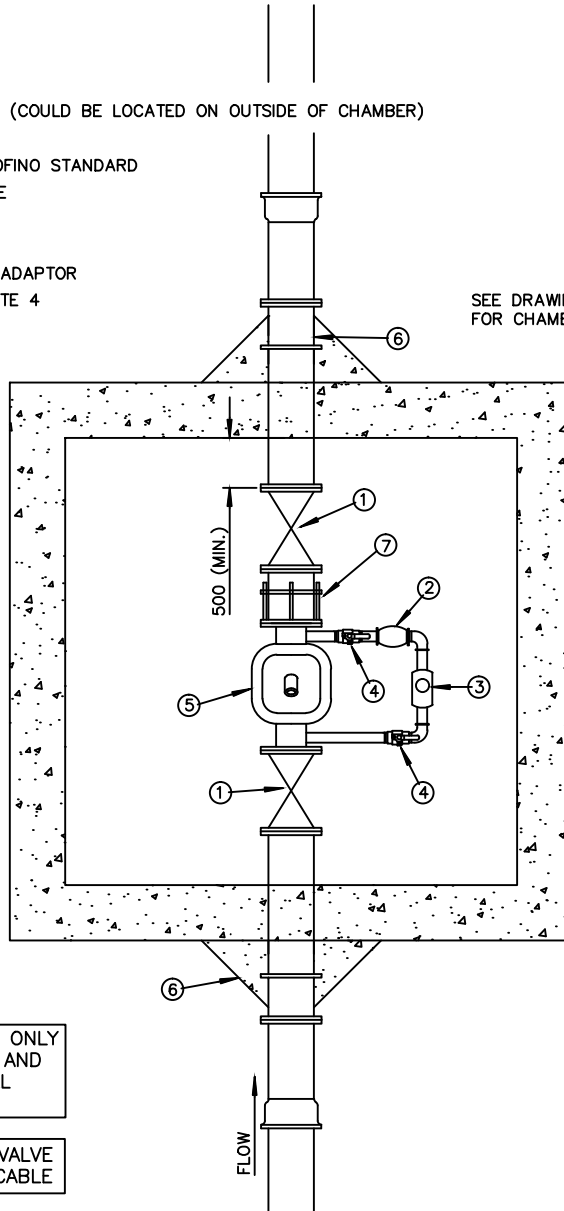

FOR GENERAL INFORMATION ONLY
DESIGN TO BE COMPLETED AND
SEALED BY A PROFESSIONAL
ENGINEER

DOUBLE DETECTOR CHECK VALVE
ASSEMBLIES MAY BE APPLICABLE

NOTES:

1. METER ASSEMBLY TO BE SUPPORTED BY STEEL PIPE SUPPORTS AS REQUIRED.
2. TEST POINTS AND DRAIN ASSEMBLIES TO INCLUDE PLUG FOR UNDERGROUND INSTALLATIONS.
3. THRUST BLOCKING TO BE INSTALLED AS REQUIRED.
4. FABRICATED STEEL PIPE AND FITTING TO BE SCHEDULE 40 SANDBLASTED, EPOXY LINED, AND COATED TO AWWA C-210 & NSF-61 SPECIFICATION.
5. ONLY PRODUCTS APPROVED BY THE SUPERINTENDENT AND LISTED IN THE DISTRICT OF TOFINO APPROVED UTILITY PRODUCT LIST WILL BE ACCEPTED FOR INSTALLATION. ONLY UL/FM LISTED PRODUCTS SHALL BE APPROVED FOR FIRE LINE SERVICE.
6. TO BE LOCATED IN A DISTRICT SRW, WHERE REQUIRED.
7. THE USE OF SINGLE DETECTOR CHECK VALVES VS DOUBLE DETECTOR CHECK VALVE ASSEMBLIES (OR OTHER) AND RELATED RIGHT OF WAYS AND MAINTENANCE (INCLUDING ON SITE FIRE HYDRANTS) MUST BE REVIEWED WITH TOFINO AND ISLAND HEALTH, MAINTENANCE, TESTING, AND OWNERSHIP OF THE BACKFLOW PREVENTION SYSTEM MUST BE DETERMINED AND PRESENTED.

| | | | | | |
|---|-------------------------------|--|---|-----------|----------------|
| 3 | | DIMENSIONS ARE IN MILLIMETERS UNLESS OTHERWISE NOTED | | | |
| 2 | | TITLE DETECTOR CHECK FIRE LINE SERVICE PIPING LAYOUT (100 TO 150) | | | |
| 1 | | | | | |
| | REVISION DATE | APPROVED | | | |
|  | DISTRICT OF TOFINO | | SUBDIVISION & DEVELOPMENT CONTROL BYLAW | | |
| | | | APPROVED | | DRAWING NUMBER |
| | | | DATE | OCT, 2015 | W14-SD |
| DRAWN BY | | JEA | | | |

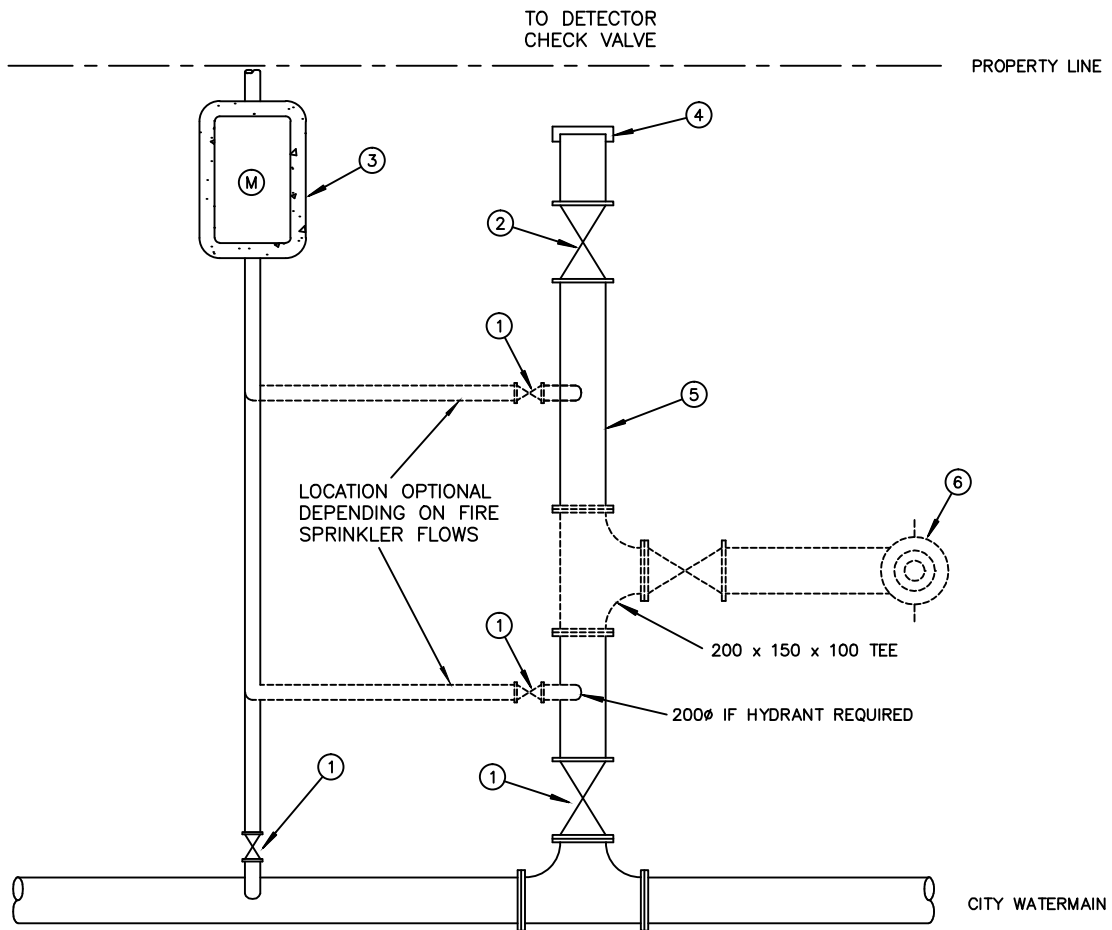

MATERIAL LIST:

- ① CORPORATION STOP, 25ø-50ø
GATE VALVE, OVER 50ø
- ② CURB STOP, 25ø-50ø (IN METER BOX)
GATE VALVE, OVER 50ø
- ③ DOMESTIC SERVICE, 25ø-50ø
- ④ CAP
- ⑤ FIRE LINE SERVICE, 38ø-100ø
- ⑥ FIRE HYDRANT ASSEMBLY (IF REQUIRED)

NOTES:

- 1. THIS STANDARD APPLIES WHERE THE FIRE LINE SERVICE IS 100ø OR LESS AND THERE ARE NO PRIVATE HYDRANTS INSTALLED ON THE SERVICE.
- 2. INSTALL THRUST BLOCKING AS REQUIRED.
- 3. ONLY PRODUCTS APPROVED BY THE SUPERINTENDENT AND LISTED IN THE DISTRICT OF TOFINO APPROVED UTILITY PRODUCTS LIST WILL BE ACCEPTED FOR INSTALLATION.

| | | | | |
|--|--|--|---------------------------------|-----------|
| 3 | | DIMENSIONS ARE IN MILLIMETERS UNLESS OTHERWISE NOTED | | |
| 2 | | | | |
| 1 | | | | |
| REVISION DATE APPROVED | | TITLE FIRE / DOMESTIC WATER SERVICE PIPING LAYOUT (38 TO 100) | | |
| DISTRICT OF TOFINO SUBDIVISION & DEVELOPMENT CONTROL BYLAW | | APPROVED | DRAWING NUMBER W15-SD | |
| | | DATE | | OCT, 2015 |
| | | DRAWN BY | | JEA |

Schedule 'F' - District of Tofino - Supplemental Specifications

Supplementary Specifications

The following sections of the MMCD Specifications are to be amended as indicated:

| MMCD Section | Subsection | Title | Supplementary Specifications |
|---------------------|-------------------|--------------------------------|--|
| 31 23 17 | 1.7 | Seismic Survey and Monitoring | <p>1.7.1 Delete wording "Contract Administrator", and replace with "Contractor".</p> <p>1.7.2 Delete wording "Owner"</p> <p>And replace with "Contractor unless otherwise indicated"</p> |
| 31 23 17 | 3.1 | Blasting and Vibration Control | <p>Add 3.1.5 "Contractor will be responsible for all damage resulting from blasting operations."</p> |
| | | | |